

Powdered Autofill Ultra™ Frozen Beverage System with 2 Hoppers



ULTRA-2 PAF

Dimensions:
42"H x 16"W x 25"D
(106.7cm H x 40.6cm W x 63.5cm D)

Features

Ultra Frozen Beverage System

- Powdered autofill product hoppers refill product at a rate of 1.1 fluid oz./sec.
- Reversing auger design quickens freeze time and reduces air mixing.
- Very simple to program and run with touchpad display, which also guides cleaning and preventive maintenance.
- Enhanced "no-lube" design on faucets and seals which simplifies installation and cleaning.
- Refrigeration system internally monitored to ensure long lasting performance.
- Two large 2 gallon (7.57 litre) hoppers for optimum cooling & serving capacity.
- Full 3-year parts and labor warranty on electronics and 5-year parts warranty on compressor. See the product manual for additional details.
- Sanitation listed by NSF to Standard 18 (includes dairy & alcohol) and safety listed by ETL to UL Standard (UL 471) and CSA Standard (C22.2 No. 120).
- International electrical configurations available.

New Energy Efficient Improvements

This new configuration consists of LED lighting in the hopper covers, an improved side panel louver pattern, and software enhancements for more efficient control of the compressor operation.

These enhancements equate to an approximate 15% reduction in energy usage vs. previous models

- LED Lighting - 5% reduction in energy usage
- New Louver pattern - 7% reduction in energy usage
- Software enhancements - 3% reduction in energy usage

For current specification sheets and other information, go to www.bunn.com.

Related Products

Conversion Kit

Kit converts hoppers on CDS-2 PAF machine to new ULTRA-2 PAF style hopper/faucet.

CDS-2 PAF Hopper Kit

Product No.: 28485.0046



Plastic hoppers pull out easily to refill powdered product.

Dimensions & Specifications

Model	Product #	Volts	Amps	Capacity	Cu Ft.	Shipping Weight	Cord Attached
ULTRA-2 PAF (White/Stainless)	34000.0500	120	15	5 lbs. dry product	21.5 ft ³	190 lbs.	Yes*
ULTRA-2 PAF (Black/Stainless)	34000.0501	120	15	5 lbs. dry product	21.5 ft ³	190 lbs.	Yes*
ULTRA-2 PAF (All Black)	34000.0504	120	15	5 lbs. dry product	21.5 ft ³	190 lbs.	Yes*

*Power cord (NEMA 5-15P) 15 Amp-120V machine only.

Electrical: Model requires 2-wires plus ground service rated 120V, single phase, 60 Hz.

Plumbing: 20-90 psi (138-621 kPa). Machine supplied with 1/4" male flare fitting.

With Extended Reach Handles

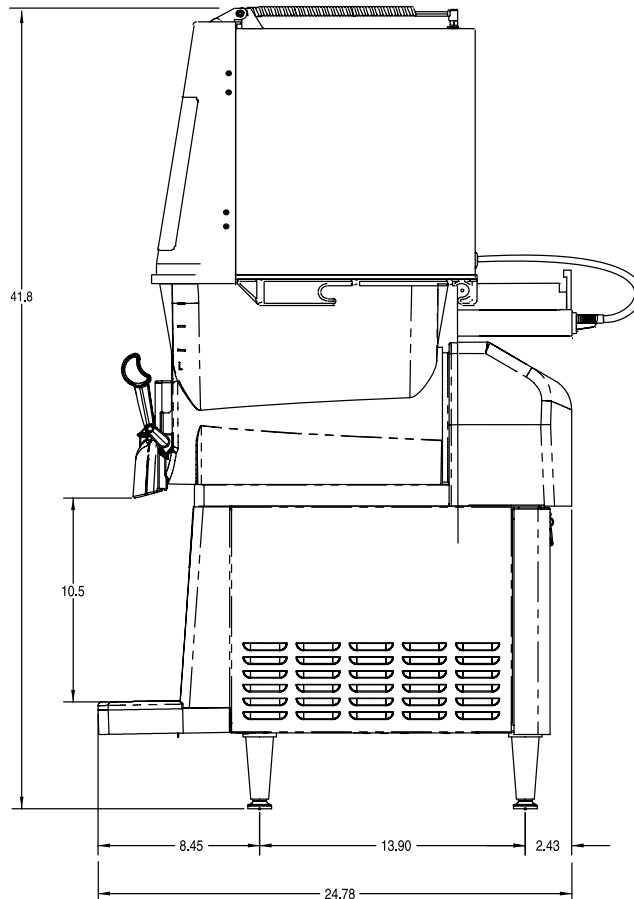
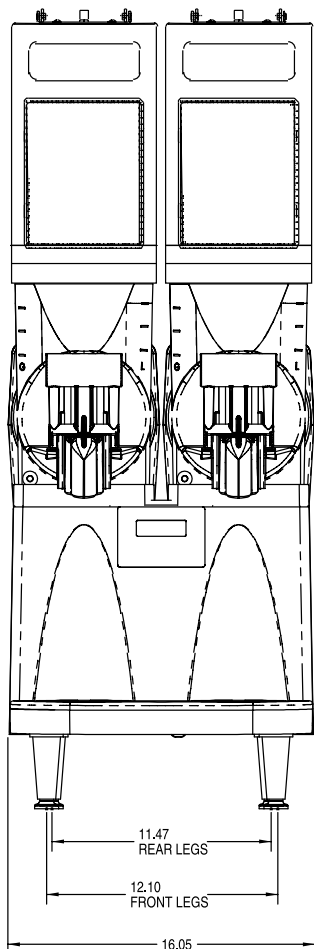
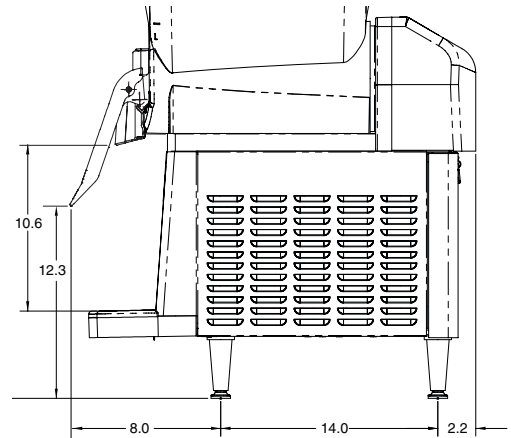

Bunn-O-Matic® Corporation - 1400 Stevenson Drive Springfield, Illinois 62703 • 800-637-8606 • 217-529-6601 • Fax 217-529-6644 • www.bunn.com

BUNN® practices continuous product research and improvement. We reserve the right to change specifications and product design without notice. Such revisions do not entitle the buyer to corresponding changes, improvements, additions or replacements for previously purchased equipment.

All dimensions shown in inches.

6/13 © Bunn-O-Matic Corporation