

**REFRIGERATOR MANUFACTURER**  
**Turbo air**  
 more durable, efficient, beautiful

4184 E. Conant St.  
 Long Beach, CA 90808  
 Tel. 310-900-1000  
 Fax. 310-900-1077  
[www.turboairinc.com](http://www.turboairinc.com)

Project :	
Model # :	
Item # :	Qty :
Available W/H :	
Approval :	

## Sandwich / Salad Unit

Food Prep Tables - Sandwich/Salad Prep  
 Super Deluxe Series

**Model : TST-48SD**



**Self-Cleaning  
 Condenser**



**NO MAINTENANCE REQUIRED**

### ≡ FEATURES & BENEFITS ≡

- **Self-cleaning condenser device** Only at Turbo Air  
 The accumulation of dust in the condenser causes the failure or breakdown of refrigerators. Refrigerators run normally until they reach a certain level of accumulation. At some point, when they are over the limit, their performance drops quickly resulting in damage to, or disposal of the stored products in refrigerators. The self-cleaning condenser device keeps the condenser clean and prevents system failure by automatically brushing daily.
- **Hot gas condensate system** Only Turbo Air models  
 Through Turbo Air's creative innovation, the condensate system surfaces have been specially treated to resist corrosion. This not only increases efficiency without the risk of refrigerant leakage from corrosion, but also prevents the overflow of condensate water.
- **Cold air compartment**  
 Our innovative "Cold air compartment" maintains temperature evenly for each pan to preserve fresh food longer. In addition, the compartment isolates pans from the reach-in area to prevent food spillage.
- **Stainless steel cabinet construction**  
 The Turbo Air Super Deluxe model boasts a stainless steel interior and exterior (galvanized steel back & bottom). It guarantees the utmost in cleanliness and long product life. The Super Deluxe can add a touch of style to the most refined setting.
- **Insulated pan cover**
- **Sturdy, clean stainless steel shelving** Only Turbo Air models  
 Shelves are the most important part of cleanliness as they come in direct contact with food. After a while, PVC coated wire shelves may peel, rust and lead to unsanitary conditions. Only the Turbo Air Super Deluxe series uniquely provides stainless steel shelving.
- **Efficient refrigeration system**  
 Turbo Air's solid door refrigerators are designed with oversized and balanced (CFC Free R-134A) refrigeration systems. These include efficient evaporators and condensers for faster cooling and greater efficiency.
- **9-1/2" deep, 1/2" thick cutting board included with convenient side rail**
- **High-density CFC free polyurethane insulation**
- **Refrigerator holds 33°F ~ 39°F for the best in food preservation**



Model	Swing Door	CU./FT.	#of Shelves	#of Pans	HP	AMPS	Crated Weight (lbs.)	L x D x H <sup>†</sup> (inches)
TST-48SD	2	12	2	12	1/3	6.5	273	48 1/4 x 30 x 37

## Model : TST-48SD

ELECTRICAL DATA	
Voltage	115/60/1
Plug Type	Ⓜ NEMA 5-15P
Full Load Amperes	6.5
Compressor HP	1/3
Feed Wires with Ground	3
Cord Length (ft.)	9
Refrigerant	R-134A
DIMENSIONAL DATA	
Ext. Length Overall (in.)	48 1/4 (1226mm)
Ext. Depth Overall (in.) *	30 (762mm)
Ext. Height Overall (in.) †	37 (940mm)
# of Doors	2
# of Shelves	2
# of Pans	12
# of Hood	1
Net Capacity (cu. ft.)	12
Net Weight (lbs.)	243
Gross Weight (lbs.)	273
Shelf Size (in.)	21 x 17

Design and specifications subject to change without notice.

Actual shipping weight may differ due to extra packing materials for product protection.

\* Depth does not include 1" for rear spacers.

† Height does not include 5" for caster height.

- **WARRANTY : 3 Year Parts and Labor Warranty**  
**Additional 2 Year Warranty on Compressor**
- **Self-contained system**
- **Standard 4" dia. swivel casters with locks on the front set**
- **Standard 1/6 size, 4" deep condiment pans included**
- **2.5" dia. casters available (optional) & Legs available (optional)**
- **Removable food covers available (optional)**
- **Stainless steel double overshelf available (optional)**
- **OPTIONAL ACCESSORIES :**
  - 2.5" caster, 1/2" diameter & 13 TPI: 30265H0100 (non-brake), 30265H0200 (w/ brake)
  - 5" caster, 1/2" diameter & 13 TPI: M726500100 (non-brake), M726500200 (w/ brake)
  - 6" ABS plastic leg: 30221M0200
  - 6" stainless steel leg: 30221M0600
  - Additional stainless steel shelf: M727800100
  - Removable food cover: RCT-48
  - Stainless steel double overshelf: TSOS-4R
- **Door lock: extra lead time will apply, please call factory for more details to order**
- **External digital thermometer: extra lead time will apply, please call factory for more details to order**

Ver.201601

## PLAN VIEW

(unit : inch)

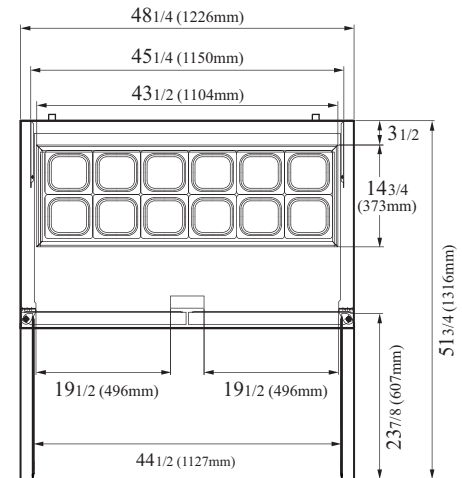

PLAN VIEW

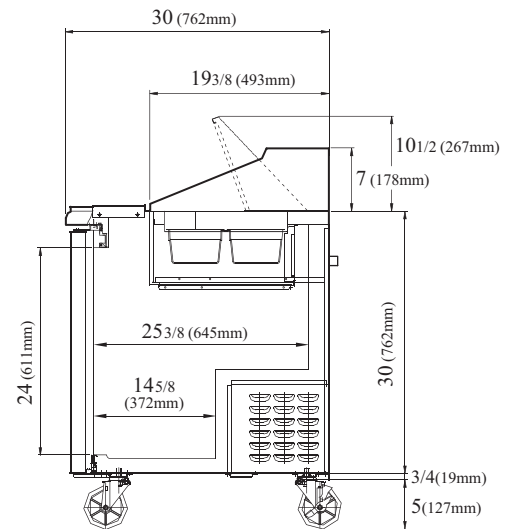

SIDE VIEW



- Turbo Air : 800-627-0032
- GK : 800-500-3519
- Warranty : 800-381-7770
- AC : 888-900-1002