

REFRIGERATOR MANUFACTURER
Turbo air
 more durable, efficient, beautiful

4184 E. Conant St.
 Long Beach, CA 90808
 Tel. 310-900-1000
 Fax. 310-900-1077
www.turboairinc.com

Project :	
Model # :	
Item # :	Qty :
Available W/H :	
Approval :	

Solid Door Freezer

Reach-In Bottom Mount
 Super Deluxe Series

Model : TSF-49SD

≡ FEATURES & BENEFITS ≡

- **Self-cleaning condenser device** *Only at Turbo Air*

The accumulation of dust in the condenser causes the failure or breakdown of refrigerators. Refrigerators run normally until they reach a certain level of accumulation. At some point, when they are over the limit, their performance drops quickly resulting in damage to, or disposal of the stored products in refrigerators. The self-cleaning condenser device keeps the condenser clean and prevents system failure by automatically brushing daily.
- **Digital temperature control & monitor system**

 - Keep food products safe by maintaining constant temperatures.
 - Alarms that sound when doors are not sealed shut; protect against food spoilage that originate from cold air leaks.
 - Digital display allows for easy monitoring.
 - Programs interpret the condition of refrigeration systems by self-diagnosis.
 - Rapid cool-down function (Turbo cooling).
 - Automatic evaporator fan motor delays.
- **Stainless steel cabinet construction**

The Turbo Air Super Deluxe model boasts a stainless steel interior and exterior (galvanized steel top, bottom and back). It guarantees the utmost in cleanliness and long product life. The sharp corners and edges have been rounded to reduce the risk of injury. The Super Deluxe can add a touch of style to the most refined setting.
- **Sturdy, clean stainless steel shelving** *Only Turbo Air models*

Shelves are the most important part of cleanliness as they come in direct contact with food. After a while, PVC coated wire shelves may peel, rust and lead to unsanitary conditions. Only the Turbo Air Super Deluxe series uniquely provides stainless steel shelving.
- **Door pressure release device** *Only Turbo Air models*

Pressure relief doors are designed to eliminates vacuum pressure and allows easy, instant door opening.
- **Efficient refrigeration system**

Turbo Air's solid door refrigerators are designed with oversized and balanced (CFC Free R-404A) refrigeration systems. These include efficient evaporators and condensers for faster cooling and greater efficiency.
- **High-density polyurethane insulation**

The entire cabinet structure and solid doors are foamed-in-place using high density, CFC free polyurethane insulation.
- **LED interior lighting**
- **Bottom mount compressor**
- **Freezer holds -10°F ~ 0°F for the best in frozen food preservation**



**Self-Cleaning
 Condenser**



NO MAINTENANCE REQUIRED



Model	Swing Door	CU./FT.	#of Shelves	HP	AMPS	Crated Weight (lbs.)	L x D x H* (inches)
TSF-49SD	2	49	6	3/4	10.5	457	54 ³ / ₈ X 30 ³ / ₈ X 78 ¹ / ₄

Solid Door Freezer

Reach-In Bottom Mount
Super Deluxe Series

Model : TSF-49SD

ELECTRICAL DATA	
Voltage	115/60/1
Plug Type	Ⓜ NEMA 5-15P
Full Load Amperes	10.5
Compressor HP	3/4
Feed Wires with Ground	3
Cord Length (ft.)	9
Refrigerant	R-404A
DIMENSIONAL DATA	
# of Doors	2
# of Racks Accepted	2
Net Capacity (cu. ft.)	49
Ext. Length Overall (in.)	54 ³ / ₈ (1382mm)
Ext. Depth Overall (in.)	30 ³ / ₈ (770mm)
Ext. Height Overall (in.)*	78 ¹ / ₄ (1987mm)
Int. Length Overall (in.)	50 ¹ / ₂ (1283mm)
Int. Depth Overall (in.)	26 ¹ / ₄ (666mm)
Int. Height Overall (in.)	60 (1524mm)
Gross Weight (lbs.)	457
# of Shelves	6
Shelf Size (L x D) (in.)	24 ³ / ₈ x 23 ¹ / ₂

Design and specifications subject to change without notice.
Actual shipping weight may differ due to extra packing materials for product protection.
* Height does not include 5" caster height or 6" optional legs.

■ WARRANTY : 3 Year Parts and Labor Warranty Additional 2 Year Warranty on Compressor

- Door locks standard
- Positive seal self-closing doors
- Easy replaceable one piece magnetic door gaskets
- Self-contained system
- Solid and sturdy grille design
- Standard 4" dia. swivel casters with locks on the front set
- Legs available (optional)
- Full and half pan racks available (optional)

■ OPTIONAL ACCESSORIES :

- 5" caster, 1/2" diameter & 13 TPI: M726500100 (non-brake), M726500200 (w/ brake)
- 6" stainless steel leg: 30221M0600
- Additional stainless steel shelf: 30278Q0200
- Half door bun tray rack: TSP-2224 (each holds up to six 18"L x 26"D sheet pans)
- Full door bun tray rack: TSP-2250 (each holds up to fifteen 18"L x 26"D sheet pans)
- Remote cabinet & condensing unit: extra lead time will apply, please call factory for more details to order

PLAN VIEW

(unit : inch)

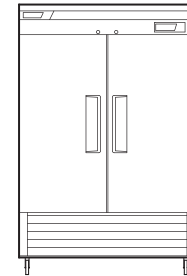

FRONT VIEW

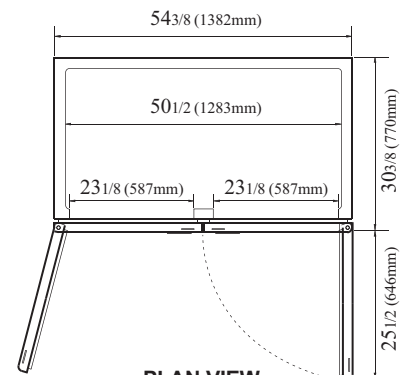

PLAN VIEW

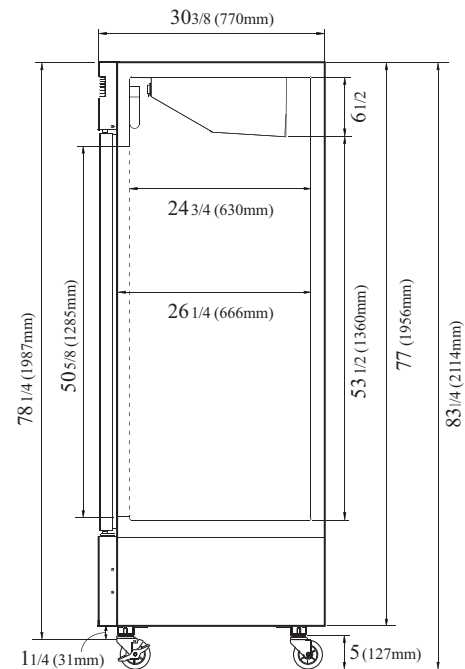

SIDE VIEW

Ver.201602



ENERGY STAR®
Qualified

- Turbo Air : 800-627-0032
- GK : 800-500-3519
- Warranty : 800-381-7770
- AC : 888-900-1002

