

The CPG Gas Char-Broiler produces a great-tasting product with attractive char-broiler markings. Reversible top grates are removable to allow for optimal grilling and easy cleanup. With flat or sloped grilling position options, you can cook multiple items to the desired level of doneness at the same time. Offering flexibility for your kitchens needs, the CPG charbroiler is available in radiant or lava rock configurations for cooking meats to perfection.

Product Features - Radiant:

- Stainless steel construction and finish
- Heavy duty cast iron top grates provide attractive char-broiler markings. Grate sections are reversible and remove easily for cleaning. The angled side helps channel oil toward the drip tray.
- Top grates can be used in flat or sloped position
- Independent, manually controlled cooking zones
- 40,000 BTU stainless steel "U" shape burners
- Each burner has a continuous pilot for instant ignition
- Removable cast iron radiants prevent clogging of burners and provide even broiling
- Removable full width waste tray
- No tools are needed to remove grates, radiant covers and stainless steel burners for cleaning
- Heavy duty adjustable feet
- 3/4" rear gas connection
- Available in 15", 24", 36" and 48" wide models
- Shipped with L.P. orifice kit for field conversion

Product Features - Lava Rock:

- Stainless steel construction and finish
- Heavy duty cast iron top grates provide attractive char-broiler markings. Grate sections are reversible and remove easily for cleaning. The angled side helps channel oil toward the drip tray.
- Top grates can be used in flat or sloped position
- Independent, manually controlled cooking zones
- 40,000 BTU stainless steel "U" shape burners
- Each burner has a continuous pilot for instant ignition
- Lava Rocks distribute heat evenly
- Cast iron lower grates support lava rocks and promote proper air flow
- Removable full width waste tray
- No tools are needed to remove grates and stainless steel burners for cleaning
- Heavy duty adjustable feet
- 3/4" rear gas connection
- Available in 15", 24", 36" and 48" wide models
- Shipped with L.P. orifice kit for field conversion



CBL36 / CBR36

Certifications:



Options & Accessories:

- Regency stainless steel stands
- Casters (front two are locking)
- Quick disconnect and flexible gas hose



PRODUCT SPECIFICATIONS

MODEL	WIDTH IN. (MM)	DEPTH IN. (MM)	HEIGHT IN. (MM)	# OF BURNERS	BTU/PER NAT/LP	TOTAL BTU/Hr	Pressure In.w.c
CBL15 / CBR15	15(381)	26.8(680)	16.3(415)	1	40,000	40,000	6/10
CBL24 / CBR24	24(610)	26.8(680)	16.3(415)	2	40,000	80,000	6/10
CBL36 / CBR36	36(915)	26.8(680)	16.3(415)	3	40,000	120,000	6/10
CBL48 / CBR48	48(1220)	26.8(680)	16.3(415)	4	40,000	160,000	6/10

Note: regulator - 75mm/3.25 inch depth. Dimensions above do not include regulator.

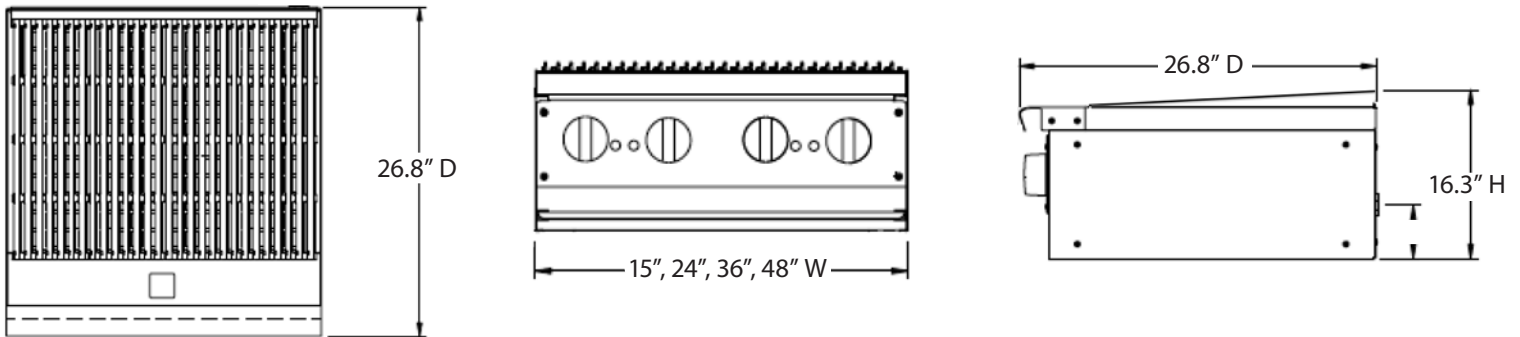

Weight:



- CBL15 / CBR15: 110 lbs.
- CBL24 / CBR24: 174 lbs.
- CBL36 / CBR36: 243 lbs.
- CBL48 / CBR48: 320 lbs.

Freight Class: 85