



Master Series Heavy Duty Combination Top Range

Item: _____
 Quantity: _____
 Project: _____
 Approval: _____
 Date: _____

Master Series Heavy Duty Combination Top Range

Models:

- M47-23R M47-23S M47-23T

Range with Valve Control Griddle & Two Open Burners



Model M47-23

Standard Features:

- Stainless steel front and side
- 6" (152mm) chrome steel adj. legs
- 7-1/2" (191mm) stainless steel front rail
- Valve controlled griddle on left with 1" (25mm) thick steel griddle plate & two 33,000 BTU (9.67kW) "H" burners
- 2-5/16" (591mm) H welded steel splash-guards, sides & back
- Clip-on stainless steel backsplash
- Removable front-mounted stainless steel grease receptacle
- Two 24,000 BTU (7kW) natural, 20,000 BTU (5.86kW) propane Starfire burners per section.
- Removable ring grates over each burner
- One-piece stainless steel drip tray
- Fully porcelainized oven interior
- Piezo Spark ignition for oven
- 40,000 BTU (11.72kW) natural, 35,000 BTU (10.25kW) propane cast iron oven burner

Optional Features:

- Stainless steel oven interior
- Stainless steel main back
- Stainless steel common front rail up to 102" (2591mm) wide (two or more units in a battery)

- Fully grooved griddle (or grooved sections)
- Convection oven base, add C to model #, e.g. M47-23RC
- Additional oven rack
- Rear gas connection, 3/4" or 1" NPT
- Gas regulator 3/4" or 1-1/4"
- Gas shut off valve; 3/4", 1" or 1-1/4" NPT
- Gas flex hose & quick disconnect (3/4", 1" or 1-1/4" NPT x 5') w/restraining device, please specify
- End caps and cover (NC, specify)
- Set of (4) Polyurethane non-marking swivel casters w/ front brakes
- 6" (152mm) stainless steel adj. legs
- Dais base (not for use with "RC" oven)
- Storage base shelf of aluminized or stainless steel
- Stainless steel tubular high shelf, single or double deck
- Stainless steel backguard: 10" (354mm), 17" (432mm) or 33" (838mm)
- 230 volt, 50 cycle components, RC motor (export)
- Celsius dial for oven thermostat (NC)

Specifications:

Heavy duty gas range, Model M47-23R with ovens with one 23" (548mm) wide x 25" (635mm) deep x 1" (25mm) thick griddle. Valve controlled griddle, bordered side and rear continuous welded stainless steel splash guards, 66,000 BTU (19.3kW) total, on left only, and two 24,000 BTU (7.0 kW) Starfire open burners with heavy duty cast iron top grates/ring grates. 34" (864mm) W x 38" (965mm) D, including 7-1/2" (191mm) deep stainless steel front rail. Porcelain enamel oven interior with 40,000 BTU (11.72kW) cast iron burner. Stainless steel front and sides. 154,000 BTU (45.10 kW) total (natural gas). Natural or propane gas. Also available with storage base with doors, M47-23S, and with modular top, M47-23T



NOTE: Ranges supplied with casters must be installed with an approved restraining device.



Product	Width: In(mm)	Depth: In(mm)	Height: In(mm) (w/ NSF Legs)	Height: In(mm) (w/o NSF Legs)	Oven/Storage Base: in(mm)		
					Width	Depth	Height
M47-23R	34(864)	38(965)	36-3/8(924)	30-3/8(772)	26-1/4(667)	29(737)**	13-1/2(343)
M47-23S	34(864)	38(965)	36-3/8(924)	36-3/8(924)	26(665)	30-1/2(773)	20-1/2(519)
M47-23T	34(864)	38(965)	36-3/8(924) w/stand	9-1/2 (241) w/o stand*	N/A	N/A	N/A

*Modular top has 1-1/2" seating flanges. **RC oven is 25" (635mm) deep .

INPUT-BTU/hr (Natural Gas)	M47-23R & M47-23RC	M47-23S & M47-23T
2 Open Burners (24,000BTU ea.)***	48,000 (14.06kW)	48,000 (14.06kW)
Griddle	66,000 (19.34kW)	66,000 (19.34kW)
Oven***	40,000 (11.72kW)	N/A
TOTAL	154,000 (45.12kW)	114,000 (33.40kW)

RC=Range w/Convection Oven R=Range w/Oven S=Range w/Storage Base T=Modular Top
 *** Open Top Burner rated 20,000 BTU (5.86kW) and Oven Rated 35,000 BTU (10.25kW) for Propane gas

INSTALLATION NOTES			Shipping Wt: (Lb/Kg) ²	
Combustible Wall Clearances ¹	Entry Clearances	Operating Pressure	M47-23R	1160/527
Sides: 14" (356mm) Back: 6" (152mm)	Crated: 39-1/4" (997mm) Uncrated: 34-1/4" (870mm)	Natural: 6" WC (15mbar) Propane: 10" WC (25mbar)	M47-23S	980/445
			M47-23T	800/364

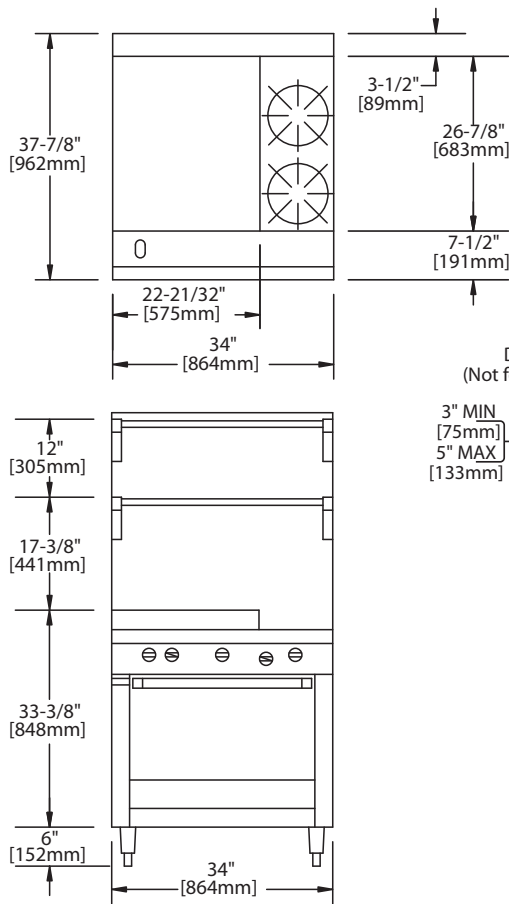

¹NOTE: Installation clearance reductions are applicable only where local codes permit.

²Shipping Cubic Feet 50 for R & S Models, 20 for T models

Data applies only to North America

Gas input ratings shown here are for installations up to 2,000 ft. (610m) above sea level. Specify altitudes over 2,000 ft.

Electrical characteristics each RC oven: 1/3 HP motor, 120 VAC, single phase, 3.4 amps, 6 ft. (1.8m) power cord with NEMA 5-15P plug provided. 230 VAC export is direct connect, single phase, 50 Hz.

Please specify gas type when ordering.

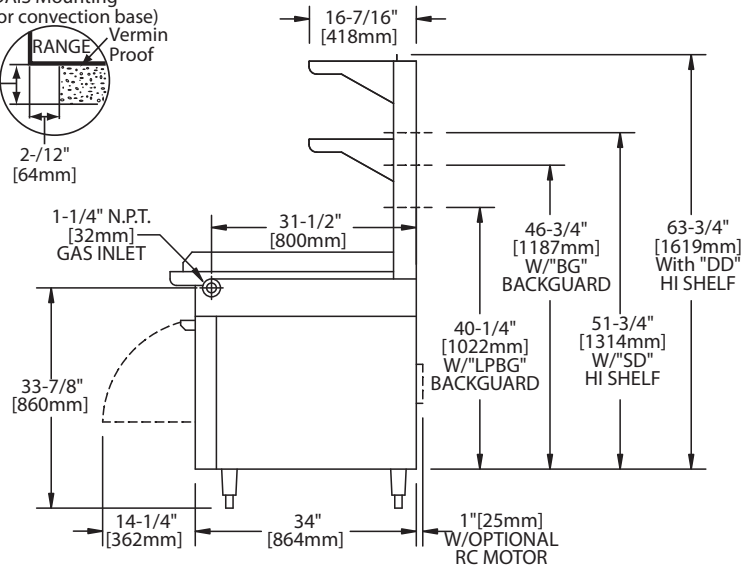
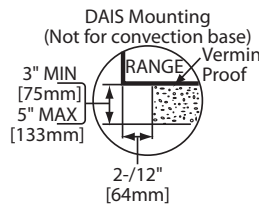

Form# M47-23 (04/08/13)