



E24 Series Heavy Duty Electric Hot Plate

Item: E24-12H

Quantity: _____

Project: _____

Approval: _____

Date: _____

E24 Series Heavy Duty Electric Hot Plate

Models:

E24-12H



Standard Features

- Stainless steel front and sides
- Removable porcelain enameled spill-over bowls
- 4" (102mm) Sanitary legs
- Heat-On indicator lamps
- Two 8 1/2" (216mm) 2.1 kW elements
- Infinite switch with "Heat On" indicator light for each element
- One-Year limited parts & labor warranty (USA & Canada only)

Options & Accessories

Stainless steel back

Note: Stands are available see form # CS24/CSD

Specifications

The Garland E24-12H electric heavy duty counter hot plate is designed and engineered for high volume fast food operations, providing fast preheat, high production and versatility with quality results. Designed as freestanding units or to bank with other E24 series equipment or with G24 series gas counter equipment providing flush fronts and backs. Stainless steel front and sides, 15" (381mm) wide x 29" (710mm) deep x 11 1/4" (286mm) high. Elements tilt up to facilitate removal of porcelain enameled spillover bowls for easy cleaning. Infinite heat switch with indicator light controls each 8 1/2" (216mm) diameter 2.1 kW element, both switches have "OFF" settings. Indicator lights are mounted on switch panel and show when element is "ON". Front access panel is removable.



Garland Commercial Ranges Ltd.
1177 Kamato Road,
Mississauga, Ontario
L4W 1X4 CANADA

General Inquiries 1-905-624-0260
USA Sales, Parts and Service 1-800-424-2411
Canadian Sales 1-888-442-7526
Canada or USA Parts/Service 1-800-427-6668



LOADING CHART									
Model	Total Kw Load	Nominal Amperes Per Line							
		3 Phase						Single Phase	
		240V			208V			240V	208V
		X	Y	Z	X	Y	Z		
E24-12H	4.2	15.2	8.8	8.8	17.5	10.1	10.1	17.5	20.2

Export voltage available on request – Specify wiring required

kW loadings are reduced on 220 volt systems.

Standard wiring 240 volt (220/240) or 208 volt (197/219) single or three phase – **Specify which is required**

Model	Overall Dimensions			Shipping Wt. Lb/kg
	Height	Width	Depth	
E24-12H	11-1/4" (286mm)	15" (381mm)	29" (737mm)	60/27

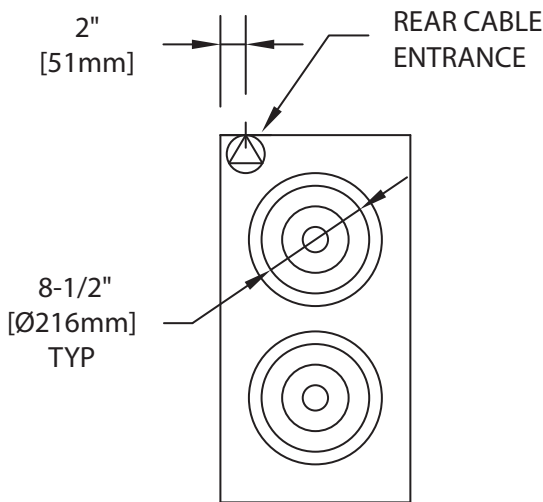

Garland products are not approved or authorized for home or residential use, but are intended for commercial applications only. Garland will not provide service, warranty, maintenance or support of any kind other than in commercial applications.

Installation Clearances	
Side	Rear
1.5" (38mm)	1.5" (38mm)

NOTE: Add 4" (102mm) to height if sanitary legs are used.

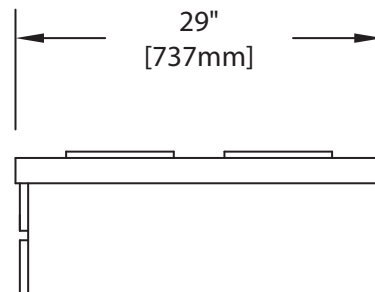
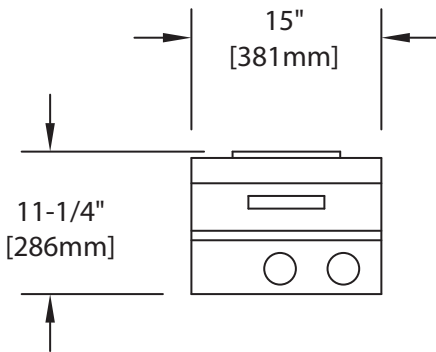

Form# E24-12H (09/19/13)