

Symphony™ ice and water dispenser with Chewblet® ice machine

25 & 50 CI series countertop



SensorSAFE infrared dispense option



Ice and water dispensers				
Ice storage capacity	Dispense	Ice machine cooling	Voltage V/Hz	Item number
25 lb (11.3 kg)	lever	air	115/60	25CI400A-L
		water	115/60	25CI400W-L
	SensorSAFE	air	115/60	25CI400A-S
		water	115/60	25CI400W-S
50 lb (22.7 kg)	lever	air	115/60	50CI400A-L
		water	115/60	50CI400W-L
	SensorSAFE	air	115/60	50CI400A-S
		water	115/60	50CI400W-S

Ice-only available, add -SI or -LI – Example 25CI400A-LI

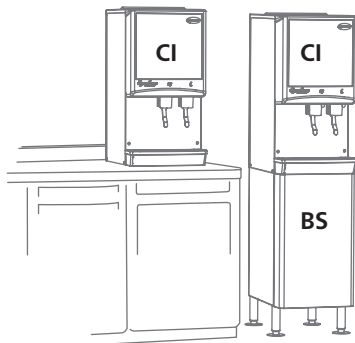

Features

25 or 50 lb (11.3 or 22.7 kg) ice storage capacity

Counter-height removable air-or water-cooled ice machine with up to 400 lb (181.4 kg) daily production of popular Chewblet ice

- modular ice machine slides out from behind lower front panel
- soft, chewable, compressed nugget ice is preferred over cubes¹ and is ideal for patient care
- environmentally responsible R404a refrigerant with zero ozone depletion potential
- water and energy efficient
- stainless steel evaporator and auger
- quiet production without noisy harvest cycles

Durable, attractive dispenser

- stainless steel exterior with accent trim
- smooth contours for aesthetically appealing appearance
- corrosion-resistant poly drain pan and dispenser lid

Designed with sanitation in mind

- Agion® silver-based antimicrobial product protection of key ice and water contact components²
- one-hand lever or SensorSAFE™ infrared ice dispense reduces the chance of cross-contamination
- SensorSAFE not recommended for use with clear containers or for applications in direct sunlight

Installation

- comes fully assembled
- three easy connections – electric, water and drain

Warranty

- 3 years parts and labor, 5 years compressor parts

Accessories

BS – Base stand (item# AF50BASESTD)

Water filter kit (item# 00130229)

High capacity water filter kit (item# 00978957)

4.00" (10.16 cm) leg kit (item# 00188417)

SafeCLEAN™ environmentally responsible ice machine cleaner (item# 00132001)

Job

Item

801 Church Lane | Easton, PA 18040, USA
1.800.523.9361 | 1.610.252.7301 | follettice.com

FOLLETT®
Innovative solutions, inspired by ice



10%
TOTAL RECOVERED FIBER
ALL POST-CONSUMER FIBER

Paper certified by:
The Forest Stewardship Council (FSC) and the Sustainable Forestry Initiative (SFI)

Specification

Ice storage capacity	25 Series – 25 lb (11.3 kg), 50 Series – 50 lb (23.7 kg)
W1 Width	21.00" (53.3 cm)
W2 Width, base stand accessory	22.75" (57.8 cm)
D1 Depth	24.00" (61.0 cm)
D2 Depth, drain pan	7.00" (17.78 cm)
D3 Depth, base stand accessory	24.38" (61.9 cm)
H1 Height	25 Series – 36.00" (91.4 cm), 50 Series – 40.00" (101.6 cm)
H2 Dispense height clearance	10.50" (26.7 cm)
H3 Height, base stand	33.00" (83.8 cm)
Ventilation clearance	air-cooled models only – 3.00" (7.62 cm) all sides
Service clearance	air-cooled models – 12.00" (30.5 cm) top, 6.00" (15.24 cm) left side water-cooled units – 12.00" (30.5 cm) top
C1 115 V/60/1 electrical	13 amps, max. fuse 20 amps. 7' (2.1 m) cord, NEMA 5-20 90° hospital-grade plug.
C2 Water inlet	3/8" FPT
C3 Drain	3/4" FPT
Utility connection location	back or bottom
Water-cooled model connections	
C4 condenser inlet	3/8" FPT
C5 condenser drain	3/8" FPT
Air temperature	50 - 100 F (10 - 38 C) indoor use only
Water temperature	40 - 90 F (4 - 32 C)
Water pressure	10 - 70 psi (69 - 483 kpa)
Ice production at 70 F (21 C) ambient air, 50 F (10 C) inlet water	air-cooled – 395 lb (179.2 kg), water-cooled – 425 lb (192.8 kg)
Ice production at 90 F (32 C) ambient air, 70 F (21 C) inlet water	air-cooled – 300 lb (136.1 kg), water-cooled – 345 lb (156.5 kg)
Energy consumption 90 F (32 C) air, 70 F (21 C) water	air-cooled models – 5.7 kWh, water-cooled models – 5.5 kWh per 100 lb (45.4 kg) ice
Heat rejection	air-cooled models – 5000 BTU/hr, water-cooled models – 1400 BTU/hr to air, 3600 BTU/hr to water
Water consumption	12.6 gal (47.7 L) of potable water per 100 lb (45.4 kg) of ice
Water flow requirement for water- cooled models	50 F / 10 C water – 60 gallons/ 100 lb of ice (276 L/ 45.4 kg)
Approximate ship weight	255 lb (115.7 kg)
NOTE: For indoor use only	

SHORT FORM SPECIFICATION: (Choose one) ___ Ice and water or ___ ice-only dispenser to be Follett® automatic load in countertop configuration, with ___ 25 lb (11.3 kg) or ___ 50 lb (22.7 kg) of storage. Environmentally responsible R404a ice machine to be (choose one) ___ air- or ___ water-cooled and to be removable for cleaning and maintenance. Dispenser frame and cabinet to be stainless steel with plastic trim. Ice machine to produce approximately 400 lb (181.4 kg) of Chewblet compressed nugget ice at air temp. of 70 F (21 C), water temp. of 50 F (10 C). Ice machine to be equipped with printed circuit board and diagnostics to allow simplified servicing. Dispenser to have automatic bin level control to start and stop ice machine and lightweight plastic top that allows full access to the ice storage area for easy cleaning and manual loading of back-up ice. Storage area to be insulated with non-CFC, high density, foamed-in-place polyurethane. 7' (2.1 m) cord and NEMA 5-20 90° hospital-grade plug provided. Dispenser to be NSF and ETL listed.

Dimensional drawing

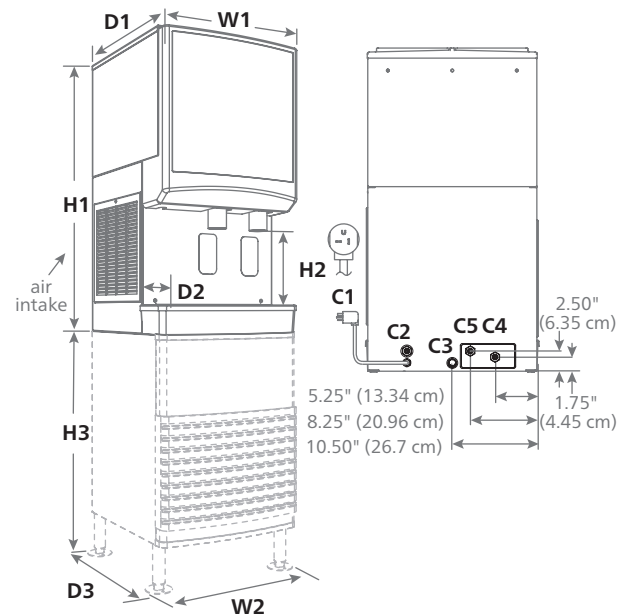

See dispenser detail sheet form# 2075 for counter cut outs

Agion is a registered trademark of Sciessent LLC.

- 1 Independent third party studies. Contact Follett for details.
- 2 Disclaimer: Antimicrobial protection is limited to the treated components and does not treat water or ice.

Symphony, SensorSAFE and SafeCLEAN are trademarks of Follett Corporation.

Chewblet and Follett are registered trademarks of Follett Corporation, registered in the US.

Follett reserves the right to change specifications at any time without obligation. Certifications may vary depending on country of origin.

25/50 CI series countertop