

## Ultra™ Frozen Beverage System with 2 Hoppers

ITEM#

PROJECT

DATE



### Ultra-2

Dimensions:

31.9"H x 16"W x 24.5"D  
(81 cm H x 40.6 cm W x 62.2 cm D)

## Features

### Ultra Gourmet Ice® System

- Reversing auger design quickens freeze time and reduces air mixing.
- Very simple to program and run with touchpad display, which also guides cleaning and preventive maintenance.
- Refrigeration system internally monitored to ensure long lasting performance.
- Two large 3 gallon (11.4 litre) hoppers for optimum cooling and serving capacity.
- Full 2-year parts and 1-year labor warranty. 5-year parts and 1-year labor warranty on compressor and 3-year parts and labor warranty on electronics. See the product manual for additional details.
- Sanitation listed by NSF to Standard 6 and 18 (including dairy & alcohol) and safety listed by ETL to UL Standard (UL 471) and CSA Standard (C22.2 No. 120).
- International electrical configurations available.
- Preventive maintenance kit: 34245.0000. 

#### Partial PM Kit contents:

- (4) LAMP, T-5 WEDGEBASE MINI 12173
- (2) BUSHING, HOPPER - AUGER
- (2) SEAL, COOLING DRUM TO SHAFT
- (2) SEAL, COOLING DRUM TO HOPPER
- (2) SEAL, FAUCET - FLAT SILICON
- (1) KIT, KRYTOX GREASE
- (1) INSTRUCTIONS

For current specification sheets and other information, go to [www.bunn.com](http://www.bunn.com).

International models may vary in appearance.

## Related Products

### Liquid Autofill Kit (LAF)

For use with external brix pumps.  
Product No.: 37960.0001 (2 valves)

### AFPO-2 SL Autofill System (Post-Mix)

Product No. : 28400.0007  
Dimensions: 7.8"H x 17.5"W x 12.7"D  
19.81 cm H x 44.45 cm W x 32.26 cm D



### Hopper Groups

Contains all hopper parts with lid.  
Product No.: 34000.0200 (white)  
Product No.: 34000.0201 (black)  
Product No.: 34000.0208 (black-flat lid)  
Product No.: 34000.0244 (white LAF)  
Product No.: 34000.0244 (black LAF)

### Hopper Kit

Contains all hopper parts but lid.  
Product No.: 34673.0000

### Conversion Kits

Kits convert hoppers on CDS-2 systems to new ULTRA-2 style hopper/faucet.  
Product No.: 28485.0042 (white)  
Product No.: 28485.0043 (black)  
Product No.: 28485.0044 (no lid)  
Product No.: 28485.0045 (flat lid)



### Ultra-2 Lid Lock Kit

Part Number: 34996.0000 (white)  
Part Number: 34996.0001 (black)

### Ultra-2 Lid Lock and Handle Lock Kit

Part Number: 34996.0002 (white)  
Part Number: 34996.0003 (black)

### Ultra-2 Handle Lock Kit

Part Number: 34996.0004 (white & black)

### Model

### Agency Listing

ULTRA-2



ULTRA-2 AF



ULTRA-2 AFI



## Dimensions & Specifications

Model	Product #	Volts	Amps	Capacity	Cubic Measure	Shipping Weight	Cord Attached
ULTRA-2 (Stainless/White)	34000.0000	120	12	2 Hoppers@3.0 gal each	14.9 ft <sup>3</sup>	137 lbs.	Yes*
ULTRA-2 (Stainless/Black)	34000.0001	120	12	2 Hoppers@3.0 gal each	14.9 ft <sup>3</sup>	137 lbs.	Yes*
ULTRA-2 (All Black)	34000.0008	120	12	2 Hoppers@3.0 gal each	14.9 ft <sup>3</sup>	137 lbs.	Yes*
ULTRA-2 (Stainless/White)**	34000.0012	120	12	2 Hoppers@3.0 gal each	14.9 ft <sup>3</sup>	137 lbs.	Yes*
ULTRA-2 (All Black)**	34000.0013	120	12	2 Hoppers@3.0 gal each	14.9 ft <sup>3</sup>	137 lbs.	Yes*
ULTRA-2 AF (Stainless/White)	34000.0023	120	12	2 Hoppers@3.0 gal each	14.9 ft <sup>3</sup>	137 lbs.	Yes*
ULTRA-2 AF (Stainless/Black)	34000.0025	120	12	2 Hoppers@3.0 gal each	14.9 ft <sup>3</sup>	137 lbs.	Yes*
ULTRA-2 AF (Black)	34000.0027	120	12	2 Hoppers@3.0 gal each	14.9 ft <sup>3</sup>	137 lbs.	Yes*
AF models include autofill hoppers designed to accept lines from AFPO-2 SL or LAF kit (used with third party brix pumps)							
ULTRA-2 AFI (Stainless/White) <sup>f</sup>	34000.0067	120	12	2 Hoppers@3.0 gal each	14.9 ft <sup>3</sup>	137 lbs.	Yes*
ULTRA-2 AFI (Stainless/Black) <sup>f</sup>	34000.0069	120	12	2 Hoppers@3.0 gal each	14.9 ft <sup>3</sup>	137 lbs.	Yes*
ULTRA-2 AFI (Black) <sup>f</sup>	34000.0068	120	12	2 Hoppers@3.0 gal each	14.9 ft <sup>3</sup>	137 lbs.	Yes*

AFI models include autofill hoppers and factory installed LAF kit for use with third party brix pumps.

\*Power cord (NEMA 5-15P) 15 Amp-120V machine only. \*\*Flat lid. <sup>f</sup>20 day item.

Electrical: Models require 2-wires plus ground service rated 120V, single phase, 60 Hz.

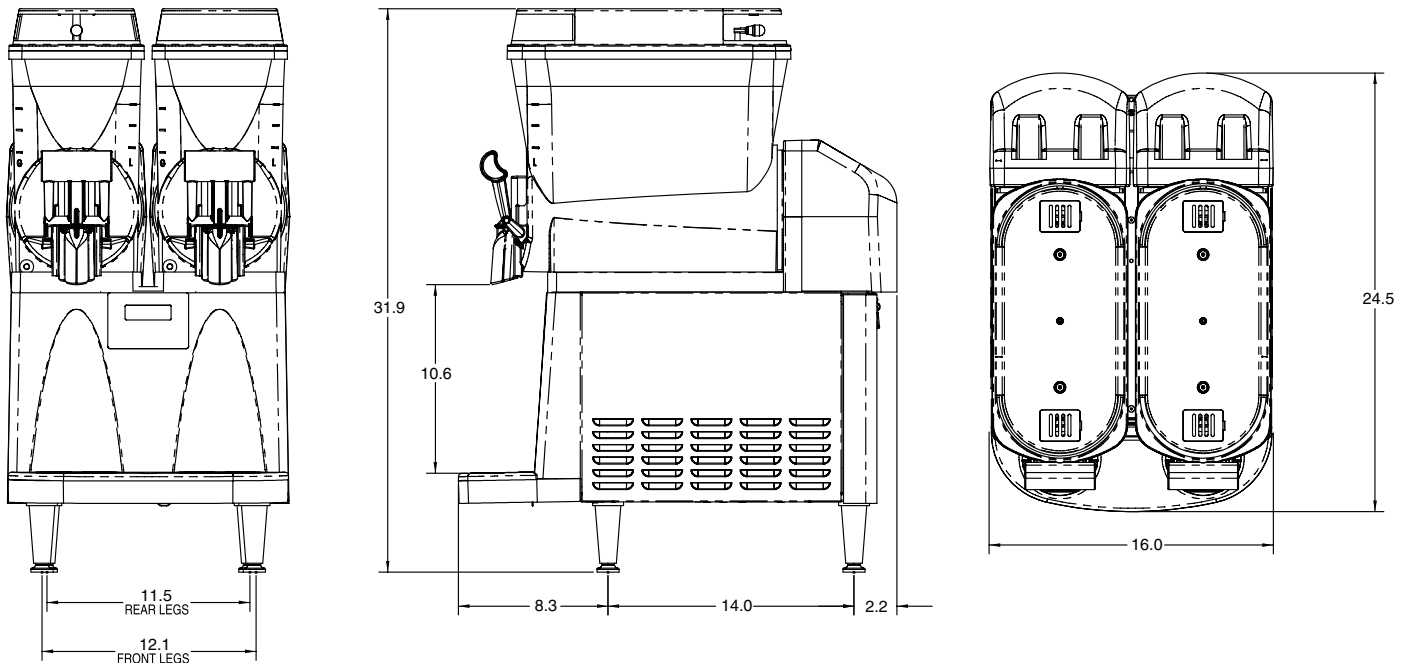

Bunn-O-Matic® Corporation - 1400 Stevenson Drive Springfield, Illinois 62703 • 800-637-8606 • 217-529-6601 • Fax 217-529-6644 • www.bunn.com

BUNN® practices continuous product research and improvement. We reserve the right to change specifications and product design without notice. Such revisions do not entitle the buyer to corresponding changes, improvements, additions or replacements for previously purchased equipment.

All dimensions shown in inches.

8/10 © Bunn-O-Matic Corporation