



CAFE SERIES REMOTE REFRIGERATOR/FREEZER

Base Units for Use Under CAFE Modular Ranges



BRLH-02R-B-36 shown with BR-36B-M 36" Modular Base Charbroiler

OPTIONS AND ACCESSORIES

(AT ADDITIONAL CHARGE)

- Cabinet extensions
 - 6" stainless steel cabinet
 - 12" stainless steel cabinet
 - 18" stainless steel cabinet
- Padlock assemblies (padlocks not included)
- Condensate evaporator

Project _____

Item No. _____

Quantity _____

- BRLH-02R-B-36 - 36" wide, 2 drawer remote refrigerator unit
- BRLH-02R-B-48 - 48" wide, 2 drawer remote refrigerator unit
- BRLH-04R-B-60 - 60" wide, 4 drawer remote refrigerator unit
- BRLH-04R-B-72 - 72" wide, 4 drawer remote refrigerator unit
- BFLH-02R-B-36 - 36" wide, 2 drawer remote freezer unit
- BFLH-02R-B-48 - 48" wide, 2 drawer remote freezer unit
- BFLH-04R-B-60 - 60" wide, 4 drawer remote freezer unit
- BFLH-04R-B-72 - 72" wide, 4 drawer remote freezer unit

Note: If required size is not listed, see options for cabinet extensions. Bases must be ordered in conjunction with Cafe Series modular base.

STANDARD FEATURES

- Cabinet interiors, front face and sides to be stainless steel
- Drawers and cabinet are 100% polyurethane "Shot-In-Place" foam insulated
- Drawer faces have flush mount pull handle. Face and back to be stainless steel
- Self closing drawers have 14 gauge stainless steel track, with 2" heavy duty skate wheel
- Heavy duty rubber drawer gaskets
- Drawers to be easily removable for cleaning
- Drawers to accommodate 6" deep 12" x 20" hotel pans
- Specially designed high density breaker strips installed during the foaming process, without any visible fasteners
- Blower coil evaporator with R-404 expansion valve unless otherwise specified
- Internal conduit for single point electrical connection
- Sleeves for refrigeration and drain lines
- Stainless steel 6" adjustable legs
- Warranty: two year parts and one year labor warranty

Note: Electrical junction box, refrigeration line stub out and drain line are all standard rear connections, consult factory if other locations are required.

*Remote units not available on casters.



CAFE SERIES REMOTE REFRIGERATOR/FREEZER

BLODGETT OVEN COMPANY

www.blodgett.com • 44 Lakeside Avenue, Burlington, VT 05401 • Phone: (802) 658-6600 • Fax: (802) 864-0183



CAFE SERIES REMOTE REFRIGERATOR/FREEZER

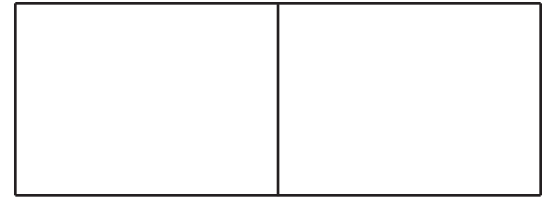

APPROVAL/STAMP

DIMENSIONS ARE IN INCHES [MM]

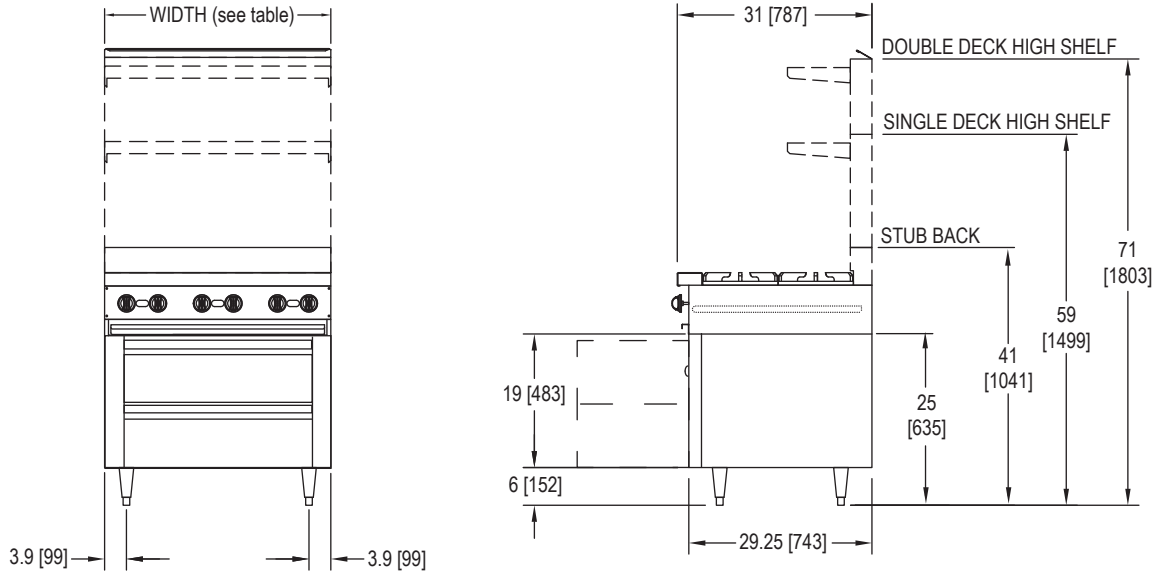

SHORT FORM SPECIFICATIONS: Provide Blodgett Low Height Remote refrigerator and freezer bases for exclusive use with Blodgett Cafe Series modular series units. To be Model #_____. Cabinet interior, front, face, drawers and sides to be stainless steel. Drawers and cabinet to be 100% polyurethane "Shot-In-Place" foam insulated. Provide easily removable self closing drawers to accommodate 6" deep 12" x 20" hotel pans and 14 gauge stainless steel track, with 2" heavy duty skate wheels. Provide heavy duty rubber drawer gaskets, face mounted dial thermometers, blower coil evaporator with R-404 expansion valve, internal conduit for single point electrical connection. Sleeves for refrigeration and drain lines. Supply stainless steel adjustable 6" legs. Two year parts/1 year labor warranty. Provide options and accessories as indicated.

MODEL	WIDTH	DEPTH	HEIGHT	DRAWERS			PANS	AMPS	SHIPPING WEIGHT*
				14-3/8"	27-1/4"	40-1/8"			
REMOTE REFRIGERATOR BASES									
JRLH-02R-B-36	36"	29.25"	See Drawing	0	2	0	4	1.45	275/125
JRLH-02R-B-48	48"	29.25"	See Drawing	0	0	2	6	3.2	350/159
JRLH-02R-B-60	60"	29.25"	See Drawing	2	2	0	6	3.2	420/190
JRLH-04R-B-72	72"	29.25"	See Drawing	0	4	0	8	3.2	475/215
REMOTE FREEZER BASES									
JFLH-02R-B-36	36"	29.25"	See Drawing	0	2	0	4	3.5	275/125
JFLH-02R-B-48	48"	29.25"	See Drawing	0	0	2	6	4.4	355/161
JFLH-02R-B-60	60"	29.25"	See Drawing	0	4	0	6	4.4	425/193
JFLH-04R-B-72	72"	29.25"	See Drawing	0	4	0	8	4.4	480/218

* Shipping weights are in lbs [kg]

ELECTRIC SPECIFICATIONS

■ Standard: 115v/60/1 (for other electrical requirements consult factory)

NOTE: The company reserves the right to make substitutions of components without prior notice

BLODGETT OVEN COMPANY

www.blodgett.com • 44 Lakeside Avenue, Burlington, VT 05401 • Phone: (802) 658-6600 • Fax: (802) 864-0183