



Bagel Master Conveyor Toaster

Models: BT-15-2 BT-15-3

PRODUCT: QUANTITY: ITEM #:

Designed Smart

Developed for High Output!

- The Bagel Master model can generate up to 1440 toasted bagel halves per hour.
- Fastest bagel toaster in the industry...toasts in 15 seconds!
- Toasters have extended super feeder and warming area to allow for high volume production.
- Unique warming area keeps bagel at the perfect temperature until you are ready to serve.

Maximum Versatility!

- A variable speed control for the conveyor produces optimum results in toasting color.
- Able to handle a variety of bagels or muffins.
- Choose from either a 2" or 3" product opening.

Safest Toaster in the Industry!

- The only toaster that protects your employees with "Cool Touch" exteriors...both sides and top surfaces.

Energy Efficient!

- Power-Saver "stand-by" switch for short off-periods helps reduce energy by 30%.

Easy to Maintain and Service!

- Conveyors and "crumb trays" are easily accessible and simple to clean.
- Removable side panel allows easy access for service.

Built Solid

Built to Last

- Stainless steel construction protects against kitchen 'wear and tear' and rust.
- Metal sheathed heating elements offer enhanced durability and consumer safety vs. quartz tube heating elements that shatter too easily.
- High Temperature insulated wire is used for long life.
- High Temperature bearings never require lubrication.

Reliability backed by APW Wyott Warranty

- All APW Wyott Bun Grill Toasters are backed by a 1-year parts and labor warranty, including on-site service calls within 50 miles of authorized service technicians.
- Certified by the following agencies:



MODEL BT-15-2 CONVEYOR TOASTER

APW Wyott Design Features

- Individually controlled top and bottom heating elements.
- Superfeeder included.
- Removable reflector tray for ease in cleaning.
- Self-dispensing bread drawer slides forward for removal of product.
- High temperature bearings never require lubrication.
- Standby switch conserves energy during slow periods.
- Lighted rocker switch.
- All stainless steel construction.
- Fully insulated and air-cooled.

Options

- Cover for speed and temperature knobs.

See reverse side for product specifications.



APW Wyott Foodservice Equipment Company · 729 Third Ave., Dallas, TX 75226
(800) 527-2100 · (214) 421-7366 · Fax (214) 565-0976 · www.apwwyott.com · info@apwwyott.com

Rev. 8/15/2005

PRODUCT: QUANTITY: ITEM #:

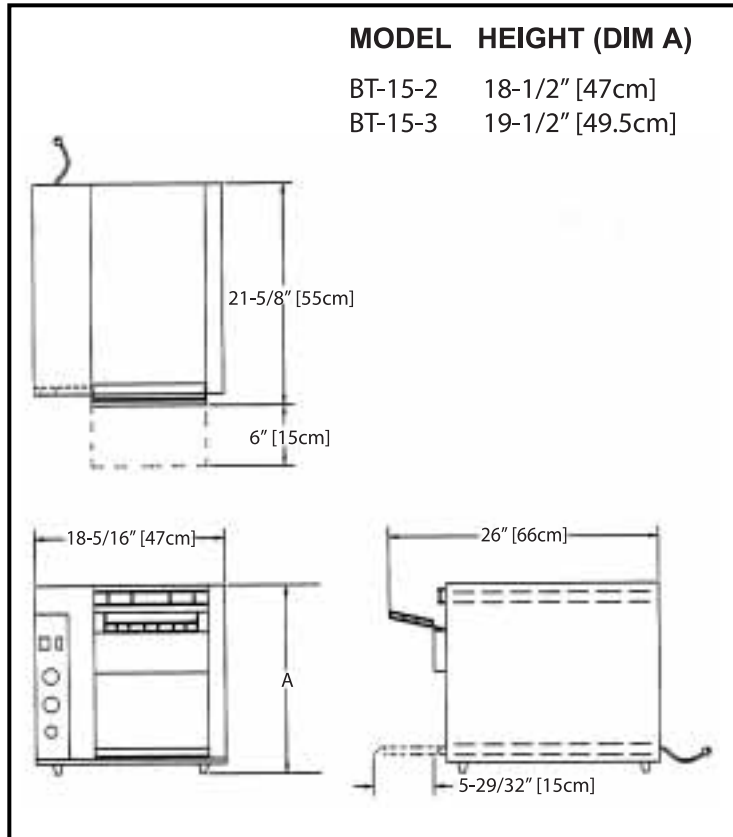

PRODUCT SPECIFICATIONS

Construction:

Stainless steel housing and radiant reflector. Metal sheathed heating elements. Stainless steel wire conveyor belt. Stainless steel front wire guard. High temperature insulation protects control panel and exteriors.

Electrical Information:

Each unit is equipped with a 39", three wire grounded power cord which terminates with a standard three-pronged male plug. The 208/240V units use a NEMA 6-30P plug.

Electrical Specifications:

BT-15-2: 208V, 4600W, 22.1 Amps
230V, 4600W, 19.8 Amps
240V, 4600W, 19.2 Amps

BT-15-3: 208V, 4600W, 22.1 Amps
230V, 4600W, 19.8 Amps
240V, 4600W, 19.2 Amps

Capacity:

BT-15-2: Up to 1440 halves per hour.
BT-15-3: Up to 1440 halves per hour.

Overall Dimensions:

BT-15-2: 18 1/2" H x 18 5/16" W x 26" D
(71.2 cm x 55 cm x 40.7 cm)

BT-15-3: 19 1/2" H x 18 5/16" W x 26" D
(77.5 cm x 62.2 cm x 44.5 cm)

Shipping:

BT-15-2: 81 lbs. (36.74 kg)
BT-15-3: 86 lbs. (39 kg)

F.O.B. Dallas, TX 75226

World Class Support

World Class Sales Support to assist you with finding the right solution to your operation's needs. Call Customer Service at 1-800-527-2100 or Fax your request to 1-214-565-0976. For more information about APW Wyott's World Class Support and High Performance Equipment, visit our website at APWwyott.com.

Most Extensive Service System in the Industry! Wyott has three levels of service support for your needs:

- Direct Service Hot Line to Service Department, call 1-800-527-2100.
- To find the Registered Service Technician in your area, call Automated Service Hot Line at 1-800-733-2203.

*APW Wyott reserves the right to modify specifications or discontinue models without incurring obligation.