



Over 90 Years Of Quality Foodservice  
Products And Service

Job \_\_\_\_\_ Item No. \_\_\_\_\_

## NSF-7 Slim Line Refrigerated Cold Pans

RCP-7200SL  RCP-7300SL  RCP-7400SL

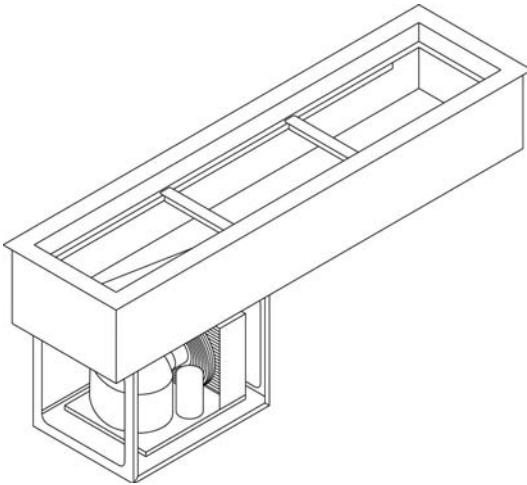

Model RCP-7300SL

### DESCRIPTION

Wells Refrigerated Slim Line Drop-In Cold Pans are designed for narrow counters and hold pre chilled food products at cold, fresh and safe serving temperatures. All models are completely self-contained in two, three or four-well models and are CFC free. Pans are recessed 3" to comply with NSF-7 performance requirements. Includes an 8 ft. 120V cord and plug (120V models).

### SPECIFICATIONS

**Exterior** – One-piece top flange and coved-corner interiors constructed of 18 gauge stainless steel. Exterior body constructed of heavy gauge, corrosion resistant steel. Condensing unit mounted on corrosion resistant frame below the cold pan.

**Interior** – CFC free foamed-in-place insulation through-out, 1" drain located in the center for easy cleaning. Ledge is recessed 3" to comply with NSF-7 requirements, allowing a layer of air to insulate food and for pan support.

**Refrigeration** – Air cooled, Type 404A CFC free refrigerant system featuring wrapped coil construction on both sides and bottom, individual thermostats, on/off switch, 8 ft. cord and plug set NEMA 5-15P (120V models). Refrigeration system features sight glass, easy service valves, dryer/filter and receiver. Condensing unit may be easily removed for service.

### STANDARD FEATURES

- 3" recessed top edge to comply with NFS-7 requirements
- Self contained drop-in design
- Hold standard 12" by 20" food pans and fractional sized pans
- Stainless steel top and liner for maximum strength and durability
- 1" drains for ease of cleaning
- On-off switch with 8 ft. cord & plug for ease of installation and operation (120V models)
- Type- 404A CFC free refrigerant
- Fully insulated, CFC free, foamed-in place insulation keeps food cold while saving energy
- Recessed ledge for pan support and colder, fresher products
- Quick & easy service with sight glass, service valves, filter/dryer and receiver
- Limited 1 year parts & labor warranty

### OPTIONS & ACCESSORIES

- 5-year compressor warranty
- Perforated bottom strainer plate conveniently holds ice above drain to prevent clogging
- Adaptor bars for fractional sized pans
- Remote on/off switch
- 220/230/240V
- 50 cycle
- Remote models (Includes compressor and condensing units and up to 20' leads)
- Remote models without compressors or condensing units
- 2nd year parts & labor warranty
- Special condenser orientation and/or compressor rack location

### CERTIFICATIONS



Sheet No. WELLRCP7SL-02/12



Wells Bloomfield • 10 Sunnen Dr. St. Louis, MO 63143 U.S.A.

Phone : (314) 678-6314 • Fax (314) 781-3636

www.wellsbloomfield.com © 2012 Wells Bloomfield • Printed in the U.S.A.

**NOTE: Specifications are subject to change without notice and are not intended for installation purposes. See installation instructions prior to installing the unit.**



Over 90 Years Of Quality Foodservice Products And Service

# NSF-7 Slim Line Refrigerated Cold Pans

□ RCP-7200SL □ RCP-7300SL □ RCP-7400SL

INCHES  
MM

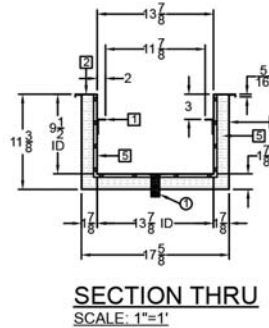
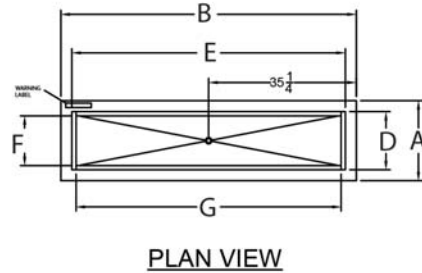

**NOTE:** Specifications are subject to change without notice and are not intended for installation purposes. See installation instructions prior to installing the unit.

**General Notes:**  
 1 16 GA S/S  
 2 18 GA S/S  
 3 18 GA GALV  
 4 20 GA GALV

RCP-7300SL Shown  
**COUNTER CUTOUT:**  
 69 1/4" X 17 7/8"

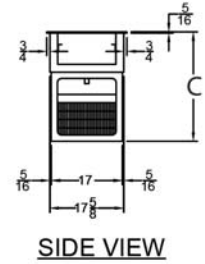
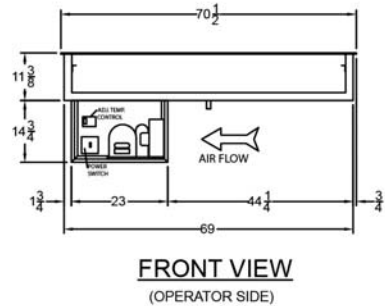
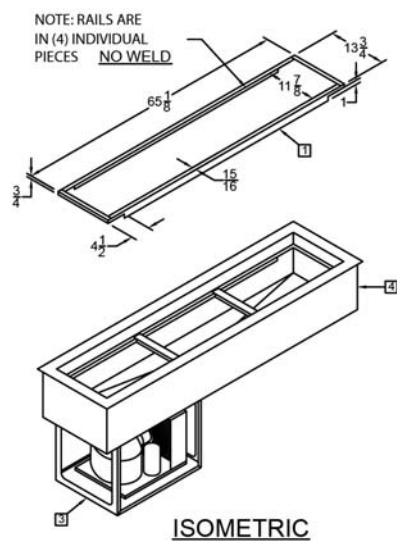
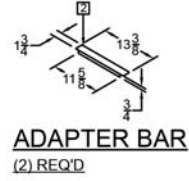

SPECIFICATIONS								SHIPPING INFORMATION							
Model Number	OVERALL DIMENSIONS			INTERIOR DIMENSIONS		CUT OUT DIMENSIONS		Model Number	WEIGHTS		CARTON DIMENSIONS			CRATE SIZE	
	A Front to Back Inches (MM)	B Left to Right Inches (MM)	C Height Inches (MM)	D Front to Back Inches (MM)	E Left to Right Inches (MM)	F Front to Back Inches (MM)	G Left to Right Inches (MM)		SHIPPING WEIGHT POUNDS (KG)	INSTALLED WEIGHT POUNDS (KG)	WIDTH Inches (MM)	DEPTH Inches (MM)	HEIGHT Inches (MM)	CUBIC FEET	CUBIC METERS
RCP-7200SL	19-1/8 (486)	49 (1244)	26-1/8 (664)	13-7/8 (352)	43-3/4 (1111)	17-7/8 (454)	47-3/4 (1213)	RCP-R200SL	220 (100)	190 (86)	29 (737)	34 (864)	32 (813)	18.26	0.52
RCP-7300SL	19-1/8 (486)	70-1/2 (1790)	26-1/8 (664)	13-7/8 (352)	65-1/4 (1657)	17-7/8 (454)	69-1/4 (1756)	RCP-R300SL	240 (108)	210 (96)	29 (737)	48 (1219)	32 (813)	25.78	0.73
RCP-7400SL	19-1/8 (486)	92 (2336)	26-1/8 (664)	13-7/8 (352)	86-3/4 (2203)	17-7/8 (454)	90-3/4 (2305)	RCP-R400SL	275 (124)	240 (109)	29 (737)	62 (1575)	32 (813)	33.3	0.94

**POWER SUPPLY- REFRIGERATION OPERATION**

Model Number	VOLTS	HP	AMPS	PHASE	POWER SUPPLY	REFRIGERANT
RCP-7100SL	115	1/4	4.9	SINGLE	NEMA 5-15P	R-404-A
RCP-7200SL	115	1/3	5.6	SINGLE	NEMA 5-15P	R-404-A
RCP-7300SL	115	1/2	6.4	SINGLE	NEMA 5-15P	R-404-A



Due to periodic changes in designs, methods, procedures, policies and regulations, the specifications contained in this sheet are subject to change without notice. While Wells exercises good faith efforts to provide information that is accurate, we are not responsible for errors or omissions in information provided or conclusions reached as a result of using the specifications. By using the information provided, the user assumes all risks in connection with such use.



**Wells Bloomfield** • 10 Sunnen Dr. St. Louis, MO 63143 U.S.A.  
 Phone : (314) 678-6314 • Fax (314) 781-3636  
 www.wellsbloomfield.com © 2012 Wells Bloomfield • Printed in the U.S.A.

**NOTE: Specifications are subject to change without notice and are not intended for installation purposes. See installation instructions prior to installing the unit.**