



Project:

Item Number:

Quantity:

Warmers: Cayenne® Models 3001D, 3002D

MODELS: 72105 120V AC, 700W
72107 120V AC, 700W



Drop-in Warmers

DESCRIPTION

Drop-ins are designed with a self-insulating, energy efficient thermoset well for ease of installation in solid-surface, laminate, or metal countertops. Minimal heat transfer to the work surface allows the drop-ins to be installed without a thermal breaker strip.

All thermoset well drop-ins have a high-efficiency cast aluminum dome element positioned in the bottom of the well for direct energy transfer. Dome element requires that the unit must be used with water in the well. All units include a standard drain and drain valve.

PERFORMANCE CRITERIA

Drop-in warmers are designed to hold heated prepared foods at temperatures above the HACCP "danger zone" of 140° F (60° C). The performance standard is measured using the NSF mixture preheated to 165° F (73.9° C). The unit will hold the temperature of this product above 150° F (65.6° C). The temperature will be maintained best when the food product is held using pans with covers, the proper water level is maintained in the well, and the food product is stirred regularly.

Agency Listings



FEATURES

- Self-insulating thermoset well with exclusive direct-contact heating system provides the optimum design for energy-efficient operation and lower operating costs
- Thermoset fiber-reinforced, self-insulating resin wells provide maximum insulation
- Low water indicator light eliminates guesswork
- 6-ft. (183 cm) cord and plug
- Top mounting installation
- Standard drain for easy cleaning
- Recommend using full or fractional size pans up to 4" (10.2 cm) deep
- Meets NSF4 performance standards
- Thermostatic temperature control
- Cast aluminum non-stick dome element

Approvals

Date:



Setting the Standard™

www.vollrathco.com

The Vollrath Company, L.L.C.
1236 North 18th Street
Sheboygan, WI 53081-3201
U.S.A.
Main Tel: 800.628-0830
Service Tel: 800.628.0832
FAX: 800.752.5620

Vollrath of Canada, Co.
Tel: 800.695.8560
FAX: 800.752.5620

Warmers: Cayenne® Models 3001D, 3002D

MODELS:	72105	120V AC, 700W
	72107	120V AC, 700W

DIMENSIONS AND RATINGS

Item	Description	Cutout Dimensions IN (CM)	Dimensions (L X W X H) IN (CM)	Voltage	Watts	Amps	Plug	Case Lot
72105	Model 3001D drop-in warmer with drain, unit-mounted temperature control	12 ⁷ / ₈ x 20 ⁷ / ₈ (32.7 x 53)	21 ³ / ₄ x 13 ³ / ₄ x 9 (55 x 33 x 23)	120V AC	700	5.8	5-15P	1
72107	Model 3002D drop-in warmer with drain, remote front mounted control panel with flexible conduit. Control Panel Dimensions: 4 ¹ / ₂ " x 6" (11.4 x 15.2 cm) Cutout Dimensions: 3 ¹ / ₂ " x 5" (8.9 x 12.7 cm)	13 ³ / ₁₆ x 21 ³ / ₁₆ (33.5 x 53.8)	21 ³ / ₄ x 13 ³ / ₄ x 9 (55 x 33 x 23)	120V AC	700	5.8	Hard Wire	1

Receptacle

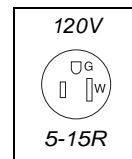

Model 72105

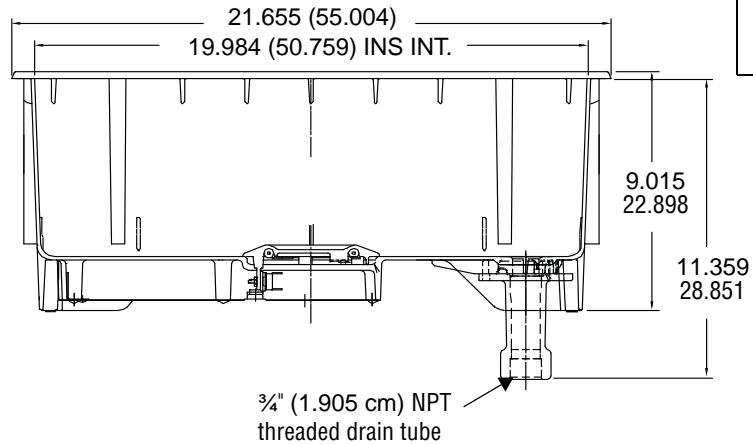
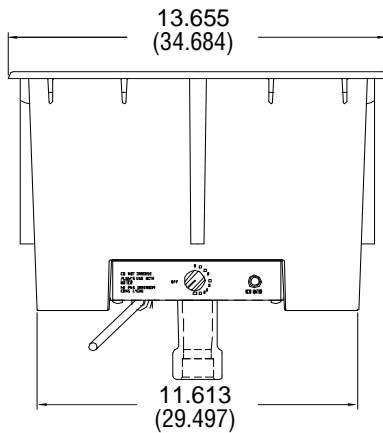

Model 72107

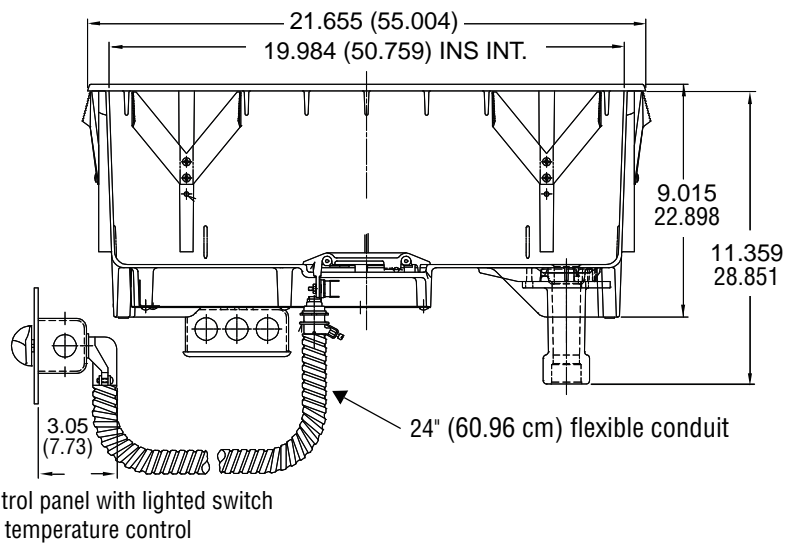
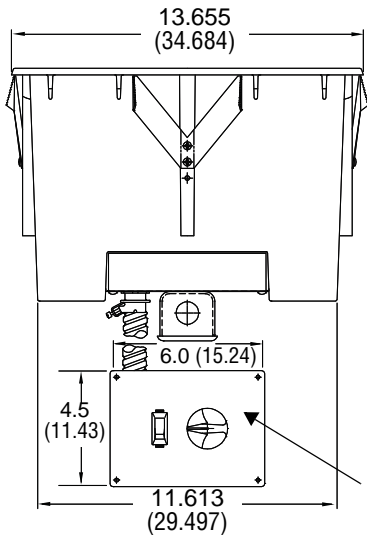

www.vollrathco.com

The Vollrath Company, L.L.C. 1236 North 18th Street Sheboygan, WI 53081-3201 U.S.A. Main Tel: 800.628-0830 Service Tel: 800.628.0832 FAX: 800.752.5620	Vollrath of Canada, Co. Tel: 800.695.8560 FAX: 800.752.5620
--	---