



TRUE FOOD SERVICE EQUIPMENT, INC.

2001 East Terra Lane • O'Fallon, Missouri 63366-4434 • (636)240-2400
 Fax (636)272-2408 • Toll Free (800)325-6152 • Intl Fax# (001)636-272-7546
 Parts Dept. (800)424-TRUE • Parts Dept. Fax# (636)272-9471 • www.truemfg.com

Project Name: _____

Location: _____

Item #: _____ Qty: _____

Model #: _____

A/A #

S/S #

Model:
TPP-93D-4

Food Prep Table:
Drawered Pizza Prep Table



TPP-93D-4

- ▶ True's pizza prep tables are designed with enduring quality that protects your long term investment.
- ▶ Oversized, environmentally friendly (R134A) forced-air refrigeration system holds 33°F to 41°F (.5°C to 5°C).
- ▶ Complies with and listed under ANSI/NSF-7.
- ▶ All stainless steel front, top and ends. Matching aluminum finished back.
- ▶ Stainless steel, patented, foam insulated flat lids keep pan temperatures colder, lock in freshness, and minimize condensation.
- ▶ Interior - attractive, NSF approved, clear coated aluminum liner. Stainless steel floor with coved corners.
- ▶ Extra-deep 19 1/2" (496 mm) full length removable cutting board included. Sanitary, high density, NSF approved white polyethylene provides tough preparation surface.
- ▶ Heavy duty, PVC coated wire shelves (door sections).
- ▶ Each drawer accommodates two (2) full size 12"L x 20"W x 8"D (305 mm x 508 mm x 204 mm) pans (sold separately).



Scan code for video

Door or drawer assemblies can be located in any section of the cabinet. Location of door/drawers must be indicated at time of ordering.

ROUGH-IN DATA

Specifications subject to change without notice. Chart dimensions rounded up to the nearest 1/8" (millimeters rounded up to next whole number).

Model	Doors	Drawers	Shelves	Pans (top)	Cabinet Dimensions (inches) (mm)			HP	Voltage	Amps	NEMA Config.	Cord Length (total ft.) (total m)	Crated Weight (lbs.) (kg)
					L**	D†	H*						
TPP-93D-4	1	4	2	12	93 1/4	32 1/4	35 3/4	1/2	115/60/1	9.7	5-15P	7	680
					2369	820	909	1/2	230-240/50/1	4.2	▲	2.13	309

** Length does not include 1/4" (7 mm) each side for cutting board brackets and thumb screws.

† Depth does not include 1" (26 mm) for rear bumpers and 3" (77 mm) for cutting board.

* Height does not include 6 1/4" (159 mm) for castors or 6" (153 mm) for optional legs.

▲ Plug type varies by country.



APPROVALS:

AVAILABLE AT:

Model:
TPP-93D-4

Food Prep Table: Drawered Pizza Prep Table



STANDARD FEATURES

DESIGN

- True's commitment to using the highest quality materials and oversized refrigeration systems provides the user with colder product temperatures, lower utility costs, exceptional food safety and the best value in today's food service marketplace.

REFRIGERATION SYSTEM

- Factory engineered, self-contained, capillary tube system using environmentally friendly (CFC free) 134A refrigerant.
- Oversized, factory balanced refrigeration system with guided airflow to provide uniform temperature in food pan rail and cabinet interior.
- Forced-air design holds 33°F to 41°F (.5°C to 5°C) product temperature in food pans and cabinet interior. Complies with and listed under ANSI/NSF-7.
- Condensing unit accessed from behind front removable panel, slides out for easy maintenance.

CABINET CONSTRUCTION

- Exterior - stainless steel front, top and ends. Matching aluminum finished back.
- Interior - attractive, NSF approved, clear coated aluminum liner. Stainless steel floor with coved corners.
- Insulation - entire cabinet structure, solid doors, and drawer facings are foamed-in-place using Ecomate. A high density, polyurethane insulation that has zero ozone depletion potential (ODP) and zero global warming potential (GWP).
- 5" (127 mm) diameter stem castors. 36" (915 mm) work surface height.

DOOR / DRAWERS

- Door or drawer assemblies can be located in any section of the cabinet. Location of door/drawers must be indicated at time of ordering.
- Door(s) constructed of stainless steel exterior with white aluminum liner to match cabinet interior. Drawers have stainless steel exterior facings and liners with stainless steel frames.

- Each door and drawer fitted with 12" (305 mm) long recessed handle that is foamed-in-place with a sheet metal interlock to ensure permanent attachment.
- Positive seal doors swing within cabinet dimensions.
- Magnetic door/drawer gaskets of one piece construction, removable without tools for ease of cleaning.
- Heavy-duty stainless steel drawer slides and rollers. Removable without tools for easy cleaning.
- Each drawer accommodates two (2) full size 12"L x 20"W x 8"D (305 mm x 508 mm x 204 mm) food pans (sold separately). Drawer will support varying pan configurations with pan dividers bars (drawer pans and divider bars optional).

SHELVING

- Four (4) adjustable, heavy duty PVC coated wire shelves. Two (2) right and two (2) left section shelf dimensions are 23 5/8" L x 28"D (601 mm x 712 mm). Center door shelf dimensions are 25 1/2" L x 28"D (648 mm x 712 mm). Four (4) chrome plated shelf clips included per shelf.
- Shelf support pilasters made of same material as cabinet interior; shelves are adjustable on 1/2" (13 mm) increments.

MODEL FEATURES

- Evaporator is epoxy coated to eliminate the potential of corrosion.
- Extra-deep 19 1/2" (496 mm), full length removable cutting board included. Sanitary, high-density, NSF approved white polyethylene provides tough preparation surface.
- Stainless steel, patented, foam insulated flat lids keep pan temperatures colder, lock in freshness, and minimize condensation.
- Refrigerated pan rail comes standard with twelve (1/2 size) 12 3/4" L x 6 1/4" W x 6"D (324 mm x 159 mm x 153 mm) NSF approved clear polycarbonate insert pans.
- NSF-7 compliant for open food product.

ELECTRICAL

- Unit completely pre-wired at factory and ready for final connection to a 115/60/1 phase, 15 amp dedicated outlet. Cord and plug set included.



115/60/1
NEMA-5-15R

OPTIONAL FEATURES/ACCESSORIES

Upcharge and lead times may apply.

- 230 - 240V / 50 Hz.
- 6" (153 mm) standard legs.
- 6" (153 mm) seismic/flanged legs.
- 4" (102 mm) diameter castors.
- 3" (85 mm) diameter castors.
- 2 1/2" (64 mm) diameter castors.
- Barrel locks available for door sections. Requires one per door (factory installed).
- Garnish racks.
- Half bun tray rack (door section only). Holds up to eleven 18"L x 26"D (458 mm x 661 mm) sheet pans (sold separately).
- 19 1/2" (496 mm) deep, 1/2" (13 mm) thick, composite cutting board.
- Pan dividers.
- Exterior round digital temperature display (factory installed).

*CABINET INTERIOR

Beginning in October of 2014, True Manufacturing began the process of changing the standard interior finishes on select products. The interior liners of these units have changed from the traditional NSF-approved white aluminum to an NSF-approved clear coated aluminum that is silver in color. In addition, the traditional white PVC coated shelves have been switched to a gray PVC coating. There are no functional differences created by any of these changes, the difference is only in the appearance. The following product lines are affected by this change: T-Series, TUC, TWT, TSSU, TFP, TPP, TMC, TRCB. A sticker will be placed on the outside packaging so that units with this change can be identified in inventory.

PLAN VIEW

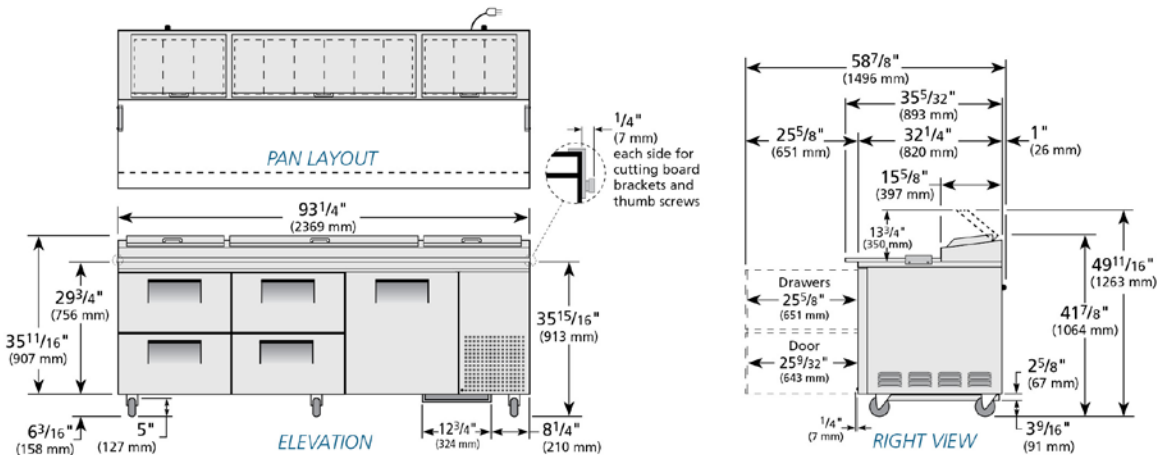

WARRANTY*
Three year warranty on all parts and labor and an additional 2 year warranty on compressor. (U.S.A. only)

METRIC DIMENSIONS ROUNDED UP TO THE NEAREST WHOLE MILLIMETER

SPECIFICATIONS SUBJECT TO CHANGE WITHOUT NOTICE



Model	Elevation	Right	Plan	3D	Back
TPP-93D-4	TFQY74E	TFQY70S	TFQY74P	TFQY743	

*RESIDENTIAL APPLICATIONS: TRUE assumes no liability for parts or labor coverage for component failure or other damages resulting from installation in non-commercial or residential applications.

TRUE FOOD SERVICE EQUIPMENT