



TRUE FOOD SERVICE EQUIPMENT, INC.

2001 East Terra Lane • O'Fallon, Missouri 63366-4434 • (636)240-2400
 Fax (636)272-2408 • Toll Free (800)325-6152 • Intl Fax# (001)636-272-7546
 Parts Dept. (800)424-TRUE • Parts Dept. Fax# (636)272-9471 • www.truemfg.com

Project Name: _____

A/A #

Location: _____

Item #: _____ Qty: _____

SIS #

Model #: _____

Model:
GDM-72FC-LD

Glass Door Floral Case:
Swing Door Refrigerator with LED Lighting



Scan code for video

GDM-72FC-LD

- ▶ The world's #1 manufacturer of glass door merchandisers.
- ▶ Oversized and balanced refrigeration system, factory sealed and pre-lubricated for long life. Designed to accommodate a broad range of floral temperature settings, holds 35°F (1.6°C).
- ▶ Exterior - non-peel or chip black laminated vinyl; durable and permanent.
- ▶ Interior - attractive, NSF approved, black aluminum interior liner with stainless steel floor.
- ▶ Self closing doors. Positive seal, torsion type closure system.
- ▶ "Low-E", double pane thermal insulated glass door assemblies with extruded aluminum frames. The latest in energy efficient technology.
- ▶ Adjustable, heavy duty black PVC coated shelves.
- ▶ LED interior lighting provides more even lighting throughout the cabinet. Safety shielded.
- ▶ Illuminated sign panel.
- ▶ Entire cabinet structure is foamed-in-place using Ecomate. A high density, polyurethane insulation that has zero ozone depletion potential (ODP) and zero global warming potential (GWP).

Bottom mounted units feature

- ▶ "No stoop" lower shelf to maximize product visibility.
- ▶ Storage on top of cabinet.
- ▶ Easily accessible condenser coil for cleaning.

ROUGH-IN DATA

Specifications subject to change without notice.
 Chart dimensions rounded up to the nearest 1/8" (millimeters rounded up to next whole number).

Model	Doors	Shelves	Cabinet Dimensions (inches) (mm)			HP	Voltage	Amps	NEMA Config.	Cord Length (total ft.) (total m)	Crated Weight (lbs.) (kg)
			L	D†	H						
GDM-72FC-LD	3	6	78 1/8 1985	29 7/8 759	78 5/8 1998	3/4 1/2	115/60/1 230-240/50/1	6.5 6.9	5-15P ▲	9 2.74	610 277

† Depth does not include 1 1/8" (29 mm) for door handles.

▲ Plug type varies by country.



APPROVALS:

AVAILABLE AT:

Model:
GDM-72FC-LD

Glass Door Floral Case: Swing Door Refrigerator with LED Lighting



STANDARD FEATURES

DESIGN

- True's commitment to using the highest quality materials and refrigeration systems provides the user with better product temperatures, and lower utility costs in an attractive merchandiser that brilliantly displays high profit floral arrangements.
- True's floral merchandisers offer interior agro lighting combined with a baffled airflow design which creates the ideal environment to prolong fresh flower shelf life.

REFRIGERATION SYSTEM

- Factory engineered, self-contained, capillary tube system using environmentally friendly (CFC free) 134A refrigerant.
- Oversized and balanced refrigeration system, factory sealed and pre-lubricated for long life. Designed to accommodate a broad range of floral temperature settings, holds 35°F (1.6°C).
- Sealed, cast iron, self-lubricating evaporator fan motor(s) and larger fan blades give True merchandisers a more efficient low velocity, high volume airflow design.
- Bottom mounted condensing unit positioned for easy maintenance; "No stoop" lower shelf maximizes visibility by raising merchandised product to higher level.
- Baffled airflow provides even air distribution for longer shelf life of fresh flowers.

CABINET CONSTRUCTION

- Exterior - non-peel or chip black laminated vinyl; durable and permanent.

- Interior - attractive, NSF approved, black aluminum interior liner with stainless steel floor.
- Insulation - entire cabinet structure is foamed-in-place using Ecomate. A high density, polyurethane insulation that has zero ozone depletion potential (ODP) and zero global warming potential (GWP).
- Welded, heavy duty steel frame rail, black powder coated for corrosion protection.
- Frame rail fitted with leg levelers.
- Illuminated exterior sign panel.

DOORS

- "Low-E", double pane thermal insulated glass door assemblies with extruded aluminum frames. The latest in energy efficient technology.
- Each door fitted with 12" (305 mm) long black PVC handle.
- Self closing doors. Positive seal, torsion type closure system.
- Magnetic door gaskets of one piece construction, removable without tools for ease of cleaning.

SHELVING

- Six (6) adjustable, heavy duty black PVC coated wire shelves 24 5/16" L x 22 1/8" D (624 mm x 562 mm). Four (4) chrome plated shelf clips included per shelf.
- Shelf support pilasters made of same material as cabinet interior; shelves are adjustable on 1/2" (13 mm) increments.

LIGHTING

- LED interior lighting provides more even lighting throughout the cabinet. Safety shielded.

MODEL FEATURES

- Evaporator is epoxy coated to eliminate the potential of corrosion

ELECTRICAL

- Unit completely pre-wired at factory and ready for final connection to a 115/60/1 phase, 15 amp dedicated outlet. Cord and plug set included.



115/60/1
NEMA-5-15R

OPTIONAL FEATURES/ACCESSORIES

Upcharge and lead times may apply.

- 230 - 240V / 50 Hz.
- White exterior.
- Mirrored back.
- 6" (153 mm) standard legs.
- 6" (153 mm) seismic/flanged legs.
- 2 1/2" (64 mm) diameter castors.
- White wire shelves.

PLAN VIEW

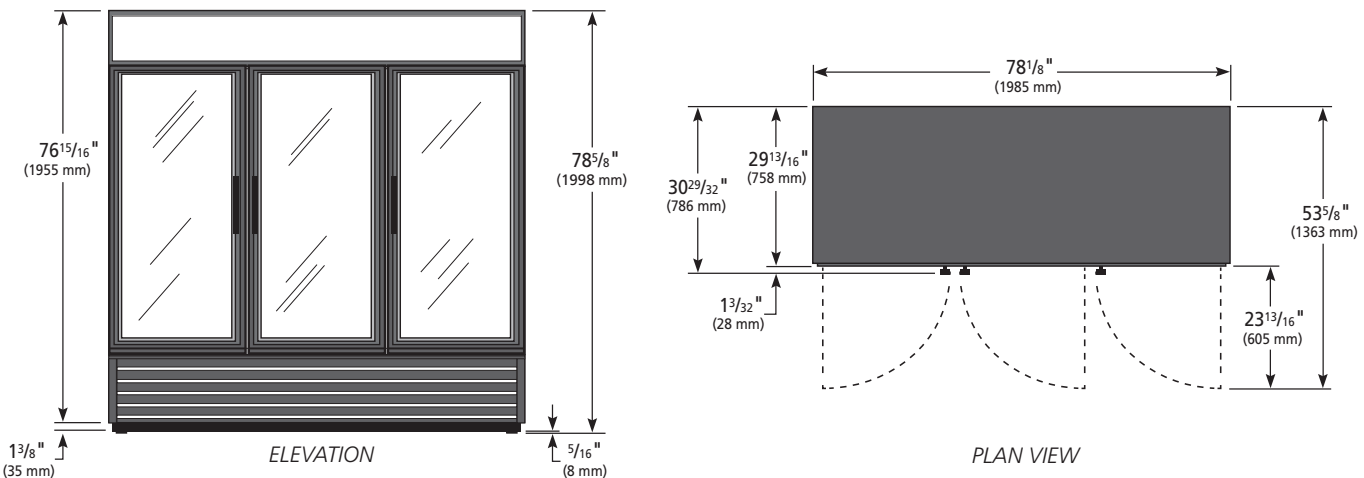

WARRANTY*

Three year warranty on all parts and labor and an additional 2 year warranty on compressor. (U.S.A. only)

METRIC DIMENSIONS ROUNDED UP TO THE NEAREST WHOLE MILLIMETER

SPECIFICATIONS SUBJECT TO CHANGE WITHOUT NOTICE



Model	Elevation	Right	Plan	3D	Back
GDM-72FC-LD	TFAY01E	TFAY01S	TFAY01P	TFAY013	

*RESIDENTIAL APPLICATIONS: TRUE assumes no liability for parts or labor coverage for component failure or other damages resulting from installation in non-commercial or residential applications.

TRUE FOOD SERVICE EQUIPMENT

2001 East Terra Lane • O'Fallon, Missouri 63366-4434 • (636)240-2400 • Fax (636)272-2408 • Toll Free (800)325-6152 • Intl. Fax# (001)636-272-7546 • www.truefmfg.com