



QMPM-48

QMPM SERIES

Quantum Series Medium Temp Open Display Merchandisers

MODELS

- QMPM-36
- QMPM-48
- QMPM-72

FEATURES

CONSTRUCTION

- 24 gauge white painted galvanized steel interior and exterior
- Removable two-tier stainless steel display deck
- Full length 8³/₄" wide laminated white formica counter top
- Automatic defrost
- On/off power switch (QMPM-36 and QMPM-48 only)
- Cord and plug (QMPM-36 and QMPM-48 only)
- 1⁵/₈" foamed-in-place "zero ODP" urethane insulation

FINISH

- White enamel interior and exterior

REFRIGERATION

- Refrigerant: R-134a
- Front air intake and rear discharge
- Electric condensate evaporator (QMPM-72 requires a separate 115V power supply for evaporator)
- Forced air ducted flow
- Self-contained, bottom mount refrigeration system
- Temperature range: 34° to 41°F (1° to 5°C)
- R-factor (insulation efficiency rating): 14.01
- Minimum of 6" clearance between cabinet back and wall and a clearance of 10" at top

WARRANTY

- Standard limited four year extended compressor and one year limited parts and labor

OPTIONS

- Add suffix "SS" for stainless steel interior and exterior
- Custom exterior colors
- Night curtain kit
- Light kit
- Night curtain/light kit
- Casters
- Sandwich racks
- Sandwich rack dividers
- 1" vinyl bumper in choice of black, blue, brown, green, red or white



QMPM SERIES

QUANTUM SERIES MEDIUM TEMP OPEN DISPLAY MERCHANDISERS

TECHNICAL SPECIFICATIONS

MODEL	DIMENSIONS (in.)			DIMENSIONS (mm)			VOLTS	AMPS	UNIT H.P.	CAP. CU. FT.	SHIP CU. FT.	SHIP WT. (LB/KG)
	L	D	H	L	D	H						
QMPM-36	36	30	43 1/4	914	775	1099	115	10.3	1/3	3.7	42.0	310/141
QMPM-48	48	30	43 1/4	1219	775	1099	115	15.5	1/2	5.1	54.0	410/220
QMPM-72	72	30	43 1/4	1829	775	1099	115/115*	15.8/10.4*	3/4	7.9	87.0	610/277

*Electric condensate evaporator requires separate power supply.

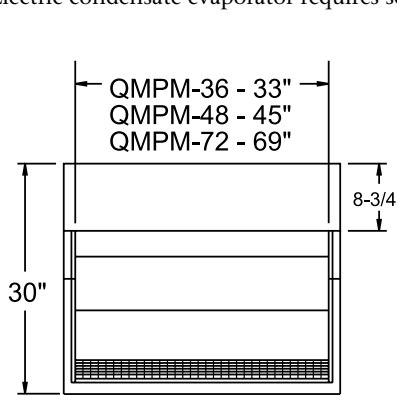

PLAN VIEW

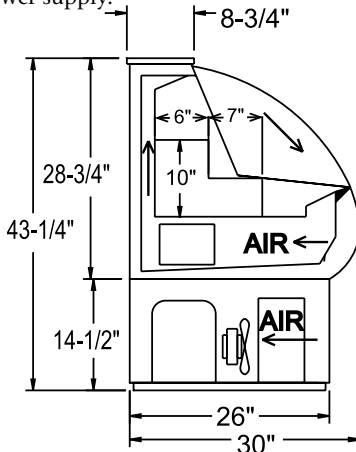

SIDE VIEW

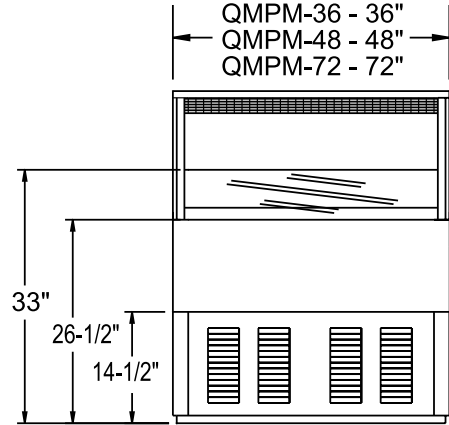

ELEVATION VIEW

LISTINGS



HOOKUP

QMPM-36 and QMPM-48 via plug in, 9 foot long, flexible 3 wire 14/3 cord with molded plug. QMPM-72 model hardwired with separate 115V junction boxes for cabinet and condensate evaporator.

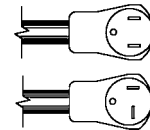

NEMA 5-15P (QMPM-36)

NEMA 5-20P(QMPM-48)

RECOMMENDED OPERATING CONDITIONS

- Merchandisers designed to hold product in the 34° to 41°F (1° to 5°C) range
- Designed to operate in air-conditioned stores where the maximum temperature is 75°F and the maximum relative humidity is 55%

- Should not be installed in direct sunlight
- Should not be installed near HVAC vents, fans or doorways that will disrupt airflow and compromise the function of the air screen inside the case
- Bottom shelf should not be loaded such

- that the front air intake is obstructed
- Factory installed controls should not be altered, removed or replaced without consent of the factory
- Product must not be displayed in the cold air curtain

BID SPECIFICATIONS

Item no. QMPM-_____
Provide _____ () Quantum Series Medium Temp Open Display Merchandiser(s), Master-Bilt model no. QMPM-_____.

Merchandiser to have removable two-tier stainless steel display deck, full length

8 3/4" wide laminated white formica counter top, automatic defrost, on/off power switch (QMPM-36 and QMPM-48 only) and have foamed-in-place "zero ODP" urethane insulation. The refrigeration system is to be self-contained, have a front condenser air intake and rear discharge

and use R-134a refrigerant. The temperature range will be 34° to 41°F (1° to 5°C). Merchandiser to have standard limited four year extended compressor warranty and one year limited parts and labor warranty. Merchandiser to be UL and C-UL listed and UL EPH classified.

NOTE: All specifications subject to change without notice.



908 Highway 15 North • New Albany, MS 38652
PHONE: 800-647-1284 or 662-534-9061 • FAX: 800-232-3966 or 662-534-6049 • www.master-bilt.com

