

Indigo™ Series 850 Ice Cube Machine

Model: ID-0852A IY-0854A ID-0853W IY-0855W ID-0892N IY-0894N



Indigo Series i-850
Ice Machine on B-570 Bin

Designed for operators who know that ice is critical to their business, the Indigo™ Series ice machine's preventative diagnostics continually monitor itself for reliable ice production. Improvements in cleanability and programmability make your ice machine easy to own and less expensive to operate.

- **Space-Saving Design** – Up to 940 lbs. (426 kgs.) daily ice production and only 30" (76.20 cm) wide.
- **Intelligent Diagnostics** – provide 24 hour preventative maintenance and diagnostic feedback for trouble free operation.
- **Acoustical Ice Sensing Probe** – for reliable operation in challenging water conditions.
- **EasyRead Display** – communicates operating status, cleaning reminders, and asset information through a blue illuminated display.
- **Programmable Ice Production** – by On/Off Time, Ice Volume or Bin Level (with accessory bin level control) further improves energy efficiency and savings.
- **Easy to Clean Foodzone** – Hinged front door swings out for easy access. Removable water-trough, distribution tube, curtain, and sensing probes for fast and efficient cleaning. Select components made with AlphaSan® antimicrobial.
- **DuraTech™ Exterior** – provides superior corrosion resistance. Stainless finish with innovative clear-coat resists fingerprints and dirt.
- Available **LuminIce™ Growth Inhibitor** controls the growth of bacteria and yeast within the foodzone.

Ice Machine Electric

208-230/60/1

(208-230/60/3 and 230/50/1 also available)

Minimum circuit ampacity:

Air-cooled:	11.9 1ph	9.2 3ph
Water-cooled:	10.9 1ph	8.2 3ph
Remote:	11.9 1ph	9.2 3ph

Maximum fuse size:

Air-cooled:	20 1ph	15 3ph
Water-cooled:	20 1ph	15 3ph
Remote:	20 1ph	15 3ph

Specifications

BTU Per Hour:

13,000 (average) 16,000 (peak)

Refrigerant:

R-404A CFC-free

Operating Limits:

- Ambient Temperature Range: 35° to 110°F (1.7° to 43.3°C)
- Water Temperature Range: 35° to 90°F (1.7° to 32.2°C)
- Water Pressure Ice Maker Water In: Min. 20 psi (137.9 kPa) Max. 80 psi (551.1 kPa)



Ice Shape



Half Dice
3/8" x 1 1/8" x 7/8"
(.95 x 2.86 x 2.22 cm)



Dice
7/8" x 7/8" x 7/8"
(2.22 x 2.22 x 2.22 cm)





Indigo™ Series 850 Ice Cube Machine

i-850 on B-570 Storage Bin

- Ⓐ Electrical Entrance (2) Options
- Ⓑ 3/8" (0.95 cm) F.P.T. Water Condenser Inlet (water-cooled units)
- Ⓒ 1/2" (1.27 cm) F.P.T. Water Condenser Outlet (water-cooled units)
- Ⓓ 1/2" (1.27 cm) Auxillary Base Drain Socket
- Ⓔ 3/8" (0.95 cm) F.P.T. Ice Making Water Inlet
- Ⓕ 1/2" (1.27 cm) F.P.T. Ice Making Water Drain
- Ⓖ 3/4" (1.91 cm) Bin Drain

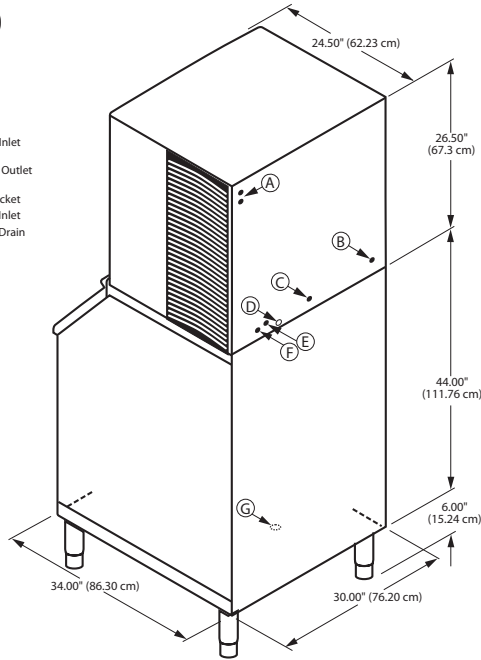

Installation Note
Minimum installation clearance:
Top/sides: 8" (20.32 cm);
Back is 5" (12.7 cm)

Space-Saving Designs



	i-850 B-570	i-850 B-970*
Height	76.50" 194.30 cm	76.50" 194.30 cm
Width	30.00" 76.20 cm	48.00" 121.92 cm
Depth	34.00" 86.30 cm	34.00" 86.30 cm
Bin Storage	430 lbs. 195 kgs.	710 lbs. 322.2 kgs.

Height includes adjustable bin legs 6.00" to 8.00", (15.24 to 20.32 cm) set at 6.00" (15.24 cm).

* For comparison purposes multiply ARI capacity by 1.3 (30%) to arrive at approximate "Application Rating Capacity."

Specifications

	Model	Ice Shape	Ice Production 24 Hours		Power Usage kWh/100 lbs. @90°Air/70°F		Water Usage/ 100 lbs. 45.4 kgs. of Ice	ENERGY STAR*
			70°Air/ 50°F Water	90°Air/ 70°F Water	1 Ph	3 Ph	Potable Water	
AIR-COOLED	ID-0852A	dice	785 lbs.	575 lbs.	6.25	6.25	20.0 Gal.	
			356 kgs.	261 kgs.			75.7 L	
AIR-COOLED	IY-0854A	half-dice	940 lbs.	650 lbs.	5.54	5.54	20.0 Gal.	★
			426 kgs.	295 kgs.			75.7 L	
WATER-COOLED	ID-0853W	dice	835 lbs.	640 lbs.	4.87	4.87	20.0 Gal.	NA
			379 kgs.	290 kgs.			75.7 L	
WATER-COOLED	IY-0855W	half-dice	875 lbs.	730 lbs.	4.52	4.52	20.0 Gal.	NA
			397 kgs.	331 kgs.			75.7 L	
* Water-cooled Condenser Water Usage / 100 lbs. /45.4 kgs. Of Ice: 150 gal/568 L. * Water-cooled models are excluded from ENERGY STAR qualification.								
REMOTE-COOLED	ID-0892N	dice	750 lbs.	610 lbs.	6.07	6.07	20.0 Gal.	
			340 kgs.	277 kgs.			75.7 L	
REMOTE-COOLED	IY-0894N	half-dice	860 lbs.	645 lbs.	5.78	5.78	20.0 Gal.	★
			390 kgs.	293 kgs.			75.7 L	

Order ice storage bin separately. Ice storage bin and JC-0895 remote condenser must be ordered separately. Consult remote condenser specification sheet for details. To order 3 phase add "3" suffix to model # (ID-0852A3).

Accessories

LuminIce™ Growth Inhibitor
reduces yeast and bacteria growth for a cleaner ice machine.



Bin Level Control
Allows ice bin level to be automatically set. Built-in LED light illuminates bin.



Arctic Pure® Water Filters
Reduces sediment and chlorine odors for better tasting ice.



AuCS®
schedules and performs routine ice machine cleaning automatically.

