



# 2612 SLICER

**HOBART**

## STANDARD FEATURES

- MICROBAN® Antimicrobial Product Protection
- Exclusive Tilting, Removable Carriage System
- Contoured Cast Stainless Steel Stay Sharp™ Knife
- Top Mounted Borazon Stone Sharpener
- Hobart Poly V-Belt Drive System
- Sanitary Burnished Aluminum Base
- Double-Action Indexing Cam
- Permanently Mounted Ring Guard
- Heavy Gauge Stainless Steel Top Cover with Integrated Product Deflector
- Cleaning Leg
- Removable Rear Deflector
- ½ H.P. Knife Drive Motor
- Nylon Carriage Roller
- Electroless Nickel Plated Single Slide Rod with Reservoir Wick
- Stainless Steel Carriage and Knife Cover
- Ergonomic Style Handle

## MODEL

- 2612 – Basic Manual Slicer with the Works
- 2612C – Basic Manual Slicer with Maximum Security Correctional Package (120/60/1 only)



## ACCESSORIES

- Low Fence
- High Fence
- Food Chute
- Heavy Meat Grip with Clips
- Heavy Handle
- 4" Legs
- Product Tray

**2612 SLICER**

## SOLUTIONS / BENEFITS

### **Microban® Antimicrobial Product Protection**

Cleaner Between Cleanings

- Inhibits the growth of bacteria, mold, mildew and fungi, keeping the slicer “cleaner between cleanings”
- Built-in and designed to last the life of the product
- Works continuously between cleanings to maintain a lower level of odor and stain causing microorganisms

### **Exclusive Tilting, Removable Carriage System**

Reduces labor, improves sanitation

- Tilt design allows for ease of midday cleaning
- Removable for complete cleaning and sanitation procedures

### **Contoured Cast Stainless Steel Stay Sharp Knife**

Reduced cost of ownership, improved yield

- Thin edge design improves yield
- Reduced maintenance cost with knife warranty

### **Top Mounted Borazon Stone Sharpener**

Ease of use, improved sanitation, reduced costs

- Single action sharpens and hones in just five seconds
- Removable and submersible for easy cleaning and sanitation
- Lifetime guaranteed Borazon sharpening stones provide maximum performance with reduced maintenance costs

### **Poly V-Belt Drive System**

Performance, durability, reduced maintenance

- Quieter operating slicer
- Patented design extends belt life while producing optimum slicing results
- More economical for service and repairs with reduced parts and reduced service time

### **Sanitary Burnished Aluminum Base**

Improved sanitation, labor savings

- One piece base protects against possible growth of bacteria
- No cracks/crevices or bolt holes where product can lodge and bacteria may grow
- Easy cleanup and durable finish

### **Double-Action Indexing Cam**

Increases reliability, easier to use, increased yield

- The first full revolution of the indexing knob provides precise control for shaving, chipping and thin slicing
- The second revolution opens the gauge plate quickly for thicker slicing

- Gauge plate holds position for consistent, precision slicing

### **Permanently Mounted Ring Guard**

Protection

- Protects knife during operation and cleaning

### **Heavy Gauge Stainless Steel Top Cover with Integrated Product Deflector**

Durability, ease of use, sanitation

- Twelve-gauge stainless steel maintains shape to ensure consistent fit
- Spring loaded knob for quick removal and easy cleanup
- One piece design for simplistic usage

### **Cleaning Leg**

Improved sanitation, ease of use

- Props machine for easy cleaning underneath slicer

### **Removable Rear Deflector**

Improved sanitation, ease of use

- Allows access for thorough cleaning
- No tools required means easy removal during cleaning

### **½ H.P. Knife Drive Motor**

Durability, performance

- Reserve power runs at 400 rpm for optimum results

### **Nylon Carriage Roller**

Performance

- Easy movement for manual operation

### **Electroless Nickel Plated Single Slide Rod with Reservoir Wick**

Performance, durability, lower maintenance

- Smooth operation with continuous lubrication of carriage rod
- Resistant to rust

### **Stainless Steel Carriage and Knife Cover**

Improved sanitation, durability

- Maximum sanitation with minimum cleanup time
- Corrosion resistant, impact resistant

### **Ergonomic Style Handle**

Operator satisfaction

- Comfortable manual operation

### **Meat Grip Options**

Multiple choices for improved yield and consistency

- Front meat grip standard
- Heavy front meat grip available

## SPECIFICATIONS

**MICROBAN® ANTIMICROBIAL PRODUCT PROTECTION:** The Microban additive is built into the external plastic components to inhibit the growth of bacteria, mold, mildew and fungi, keeping the slicer “cleaner between cleanings.” The additive is designed to last the life of the products in which it is incorporated and works continuously to maintain a lower level of odor and stain causing microorganisms.

**TILTING REMOVABLE CARRIAGE SYSTEM:** Positive angle carriage design enables operator to slice without manual feed. The stainless steel carriage system tilts back easily for midday cleaning and is removable for thorough cleaning and sanitation procedures. The carriage has 12½" manual travel.

**CONTOURED CAST STAINLESS STEEL STAY SHARP KNIFE:** Hobart Stay Sharp, contoured cast solid stainless steel, 11¾" diameter with sanitary hub. Knife is protected by a permanently mounted ring guard with integrated product deflector. The stainless steel knife cover provides easy access for cleaning. Gauge plate protects knife edge when closed. Knife cover is quickly removed with a quarter turn of the spring loaded locking knob.

**TOP MOUNTED BORAZON STONE SHARPENER:** One lever operation utilizing two Borazon stones to sharpen and hone in five seconds. Removable and top mounted. When sharpener is removed for cleaning, knife edge is shielded. Borazon stones have lifetime guarantee.

**HOBART POLY V-BELT DRIVE SYSTEM:** Knife is driven by a Hobart Poly V belt and runs at 400 rpm for optimal performance.

**SANITARY BURNISHED ALUMINUM BASE:** One-piece base protects against possible growth of bacteria. All surfaces are durable and smooth, presenting no holes or crevices in which food can lodge.

**DOUBLE-ACTION INDEXING CAM:** First revolution of index cam for precision slicing; second revolution for thicker slicing selection. Indexing cam holds true to setting during slicing operation.

**PERMANENTLY MOUNTED RING GUARD:** Permanently mounted ring guard with integrated product deflector protects knife.

**HEAVY GAUGE STAINLESS STEEL TOP COVER WITH INTEGRATED PRODUCT DEFLECTOR:** One piece design made of 12 gauge stainless steel, durable to maintain shape and ensure consistent fit. Spring loaded knob for quick removal and replacement.

**CLEANING LEG:** Cleaning leg supports the slicer in tilted position for cleaning beneath the machine.

**REMOVABLE REAR DEFLECTOR:** No tools are required for removal of the deflector for thorough cleaning of the slicer.

**KNIFE MOTOR:** ½ H.P., permanently lubricated ball bearings. Single phase capacitor-start, induction run.

**ELECTROLESS NICKEL PLATED SINGLE SLIDE ROD WITH RESERVOIR WICK:** Transport slide rod is E-Nickel electroless plated. Slide rod bearings feature an oil reservoir/oil wick.

**FINISH:** Stainless steel carriage, gauge plate, and knife cover. Burnished aluminum base.

**ERGONOMIC STYLE HANDLE:** Specially designed for ease of use during manual operation.

**MEAT GRIP:** Front mounted grip is high strength thermoplastic. Swings out of way when not in use.

**ELECTRICAL SPECIFICATIONS:** 120/60/1 and 240/60/1 (2.5 amps) – U L Listed. Also available in 100/50/60/1 and 230/50/1 (2.5 amps) – not submitted for U L Listing.

**SWITCH:** Moisture protected toggle type, operated by a push-pull rod.

**CORD & PLUG:** 6-foot, three-wire power supply cord and plug. Plug not furnished on export models.

**CAPACITY:** The carriage will take food up to 12" in width or 7½" in diameter.

**GAUGE PLATE:** Gauge plate is a heavy aluminum casting with ribbed laminated stainless steel face for smooth feeding. Adjustable to cut any thickness of slice up to 1".

**WARRANTY:** All parts and service coverage for one year including knife. Lifetime guarantee on Borazon stones in the sharpening system.

**WEIGHTS FOR THE FOLLOWING ITEMS:** Tubular Chute 9.1 lbs.; Swing Arm .61 lbs.; Heavy Front Meat Grip 2.76 lbs.; Heavy Handle 2.7 lbs.; Standard Meat Grip 2.34 lbs.

**WEIGHT:** Shipping 135 lbs., Net 96 lbs.

# 2612 SLICER



LISTED BY: UNDERWRITERS LABORATORIES INC AND NSF INTERNATIONAL.

## DETAILS AND DIMENSIONS

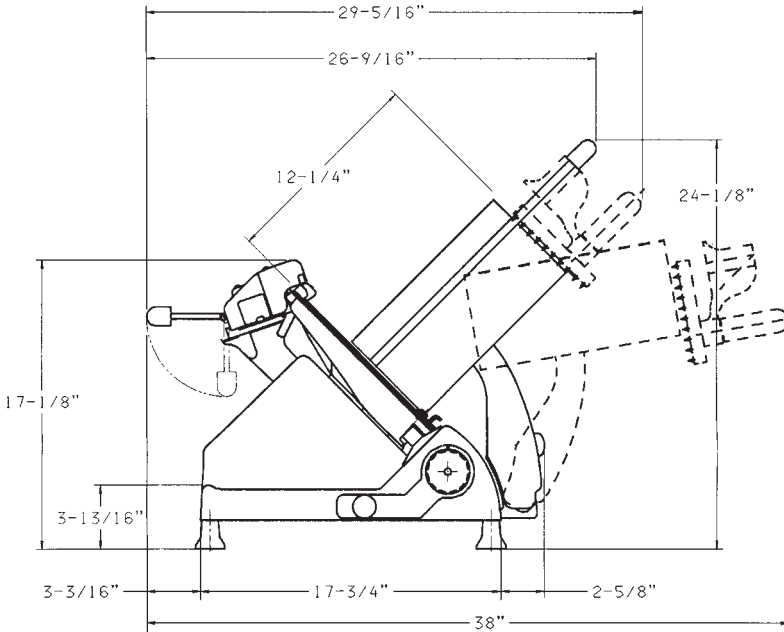

### WARNING

ELECTRICAL AND GROUNDING CONNECTIONS MUST COMPLY WITH THE APPLICABLE PORTIONS OF THE NATIONAL ELECTRICAL CODE AND/OR OTHER LOCAL ELECTRICAL CODES.

11-3/4"  
KNIFE DIA.

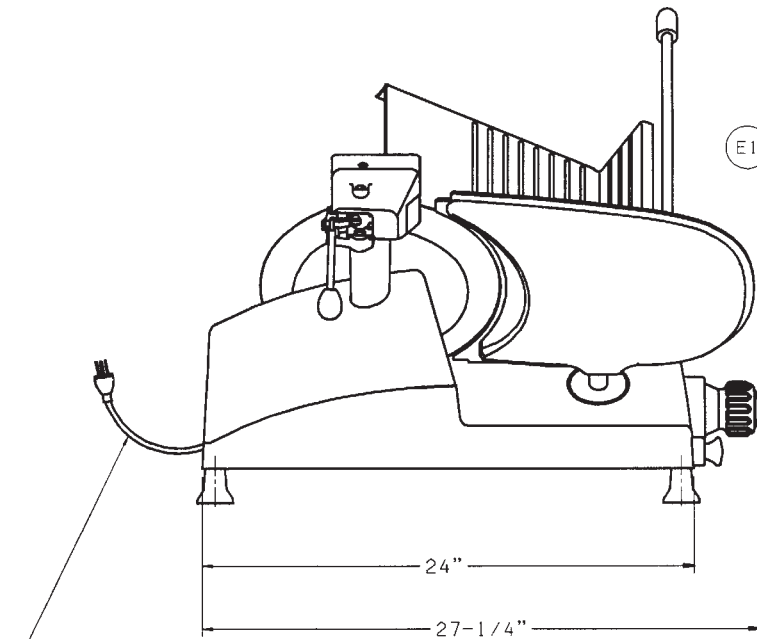
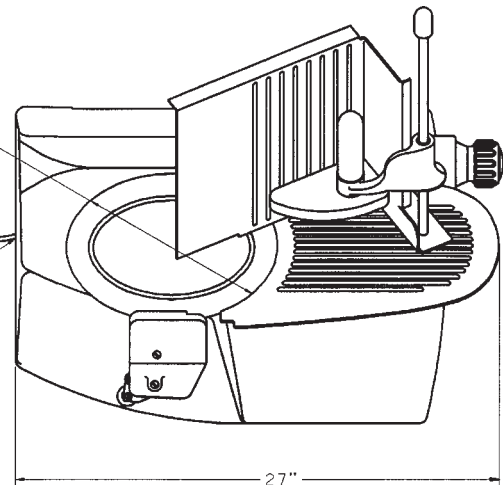

POWER CORD  
APPROX 6 FT  
LONG

### LEGEND

E1-ELECTRICAL CONNECTION,  
APPROX 2<sup>11</sup>/<sub>16</sub>" ABOVE  
COUNTER TOP

Microban and the Microban symbol are registered trademarks of the Microban Products Company, Huntersville, NC.

As continued product improvement is a policy of Hobart, specifications are subject to change without notice.

701 S Ridge Avenue, Troy, OH 45374 • 937-332-3000 • 1-800-333-7447