



KM-101BAH

SELF-CONTAINED CUBER
WITH BUILT-IN STORAGE BIN



KM-101BAH
04/25/17
Item # 13209

W x D x H
23^{3/4}" x 24^{1/4}" x 39" *
*including 6" legs

KM-101BAH ★
Air-Cooled



Item #: _____
Project: _____
Qty: _____
AIA#: _____

Features

- ▶ Individual crescent cube
- ▶ Stainless steel evaporator
- ▶ CycleSaver™ design

- Up to 115 lbs. of ice production per 24 hours
- Up to 53 lbs. of built-in storage capacity
- Durable stainless steel exterior
- Front in, front out airflow
- Slide in door
- Removable air filter
- Power switch accessible without panel removal
- Built-in installation possible
- EverCheck™ alert system
- R-134a Refrigerant
- *Optional Drain pump assembly - HS-5061*

Warranty:

3 Year Parts & Labor on entire machine. 5 Year Parts & Labor on Evaporator. 5 Year Parts on Compressor; air-cooled condenser coil. 1 Year - HS-5061 Drain Pump Assembly - Parts & Labor. Valid in United States, Canada, Puerto Rico and U.S. Territories. Contact factory for warranty in other countries.

Condenser	Model	ICE PRODUCTION				WATER USAGE			ELECTRICAL			Heat Rejection BTU/hr.	Shipping Weight	ENERGY STAR®
		Air / Water Temp Lbs. per 24 hours 70°/ 50°F	90°/ 70°F	Per Cycle Lbs.	Cubes	Potable Gal. per 100 lbs. 90°/ 70°F	Condenser Gal. per 100 lbs. 90°/ 70°F	kWh Used per 100 lbs. 90°/ 70°F	Max. Fuse Size or HACR Circuit Breaker	Amperage	Voltage			
Air-Cooled	KM-101BAH	115	88	2.31	110	23.0	N/A	9.4	15A	5.2A	115V/60/1	1,950	143 lbs.	★

KM Cube Dimensions*

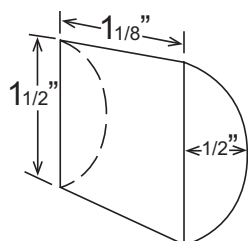

* approximate size in inches, image not to scale

Operating Limits

- Ambient Temp Range 45 - 100°F
- Water Temp Range 45 - 90°F
- Water Pressure 10 - 113 PSIG
- Voltage Range 104 - 127V

Service

- Allow enough space at rear for water supply and drain connections, at least 12" (30 cm) clearance at front and at least 0.6" (15 mm) clearance at top for maintenance.

Plumbing

- Icemaker Water Supply Line: Minimum 1/4" Nominal ID Copper Water Tubing or Equivalent
- Icemaker Drain Line: Minimum 3/4" Nominal ID Hard Pipe or Equivalent



KM-101BAH

SELF-CONTAINED CUBER
WITH BUILT-IN STORAGE BIN



KM-101BAH
04/25/17
Item # 13209

mm
[inch]

FRONT VIEW

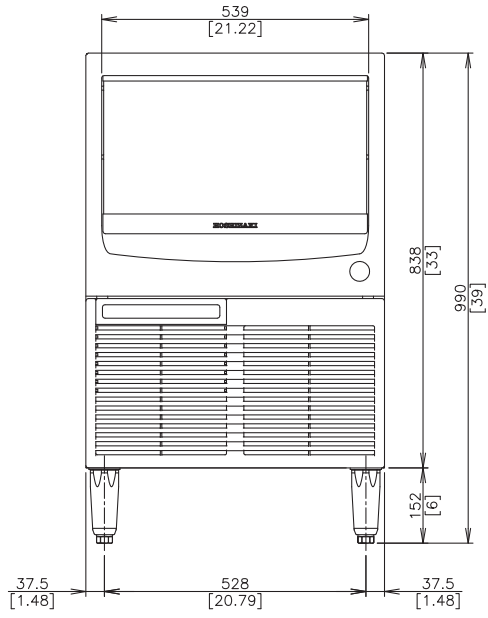

TOP VIEW

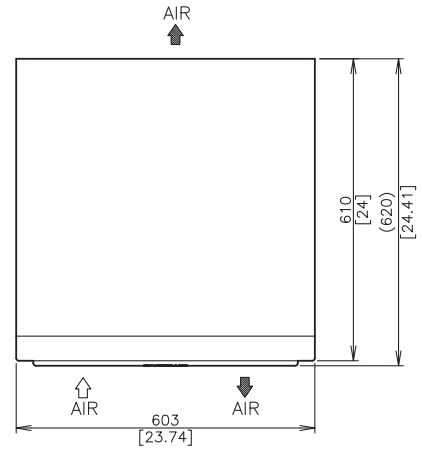

SIDE VIEW

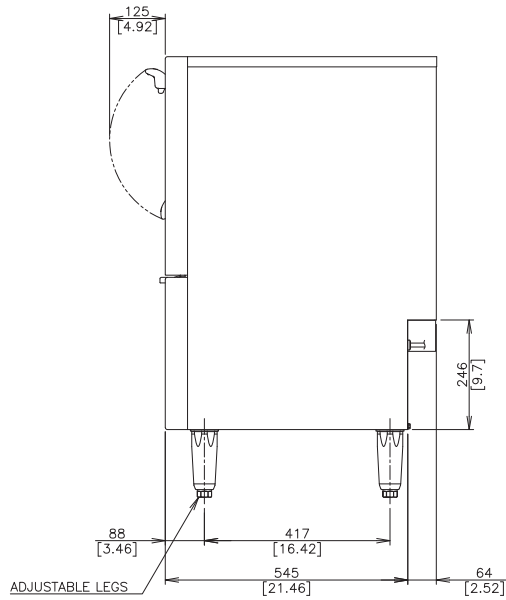

REAR VIEW

