

# HCD-500/1000B

## ICE BAGGING SYSTEM

Item # \_\_\_\_\_

Project: \_\_\_\_\_

Qty: \_\_\_\_\_

\*AutoCad available on KCL

**HCD-500/1000B**

**10/14**

**Item # 13237**

**DIMENSIONS**  
W x D x H

**HCD-500B**  
30 x 36 x 71

**HCD-1000B**  
48 x 36 x 71



**HCD-500B**

Ice Bagging System  
Shown  
with a KM-901MRH

**HCD-1000B**

Ice Bagging System

**HCD-500B**

- Ice storage capacity of 647 lbs. - ideal for limited space
- Safety overload lighted reset button

**HCD-1000B**

- Ice storage capacity of 1078 lbs.
- Equipped with Dual Agitators for easier ice management
- Built-in recovery safety torque overload

**HCD- 500/1000B**

- Unit has an ice drop rate of 120 lbs. per minute
- All stainless steel exterior finish
- Superior seamless poly liner unlike competitor units
- Stainless steel auger and agitator
- Front ice shovel door
- Stainless steel adjustable bag shelf
- 48" heavy duty ice paddle shipped with every dispenser
- Safety interlock door switch prevents operation when door is open
- 24V foot activated pedal
- 115v/60Hz/1 phase power supply



*Kloppenberg Product*

**Warranty**

**2 year P&L warranty through Kloppenberg.**

Valid in United States, Canada, Puerto Rico, & U.S. Territories. Contact Kloppenberg for warranty in other countries.



# Hoshizaki

## HCD-500/1000B ICE BAGGING SYSTEM

### DIMENSIONS

W x D x H  
**HCD-500B**  
 30 x 36 x 71  
**HCD-1000B**  
 48 x 36 x 71

• Ice bagging system

### SPECIFICATIONS

Model Number	Amperage	Min. Circuit Ampacity	Shipping Weight
HCD-500B	8.4	10.8	510 lbs.
HCD-1000B	8.4	10.8	590 lbs.

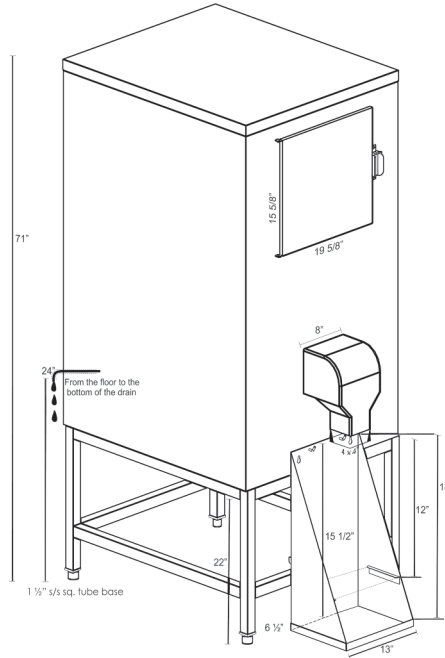

HCD-500B

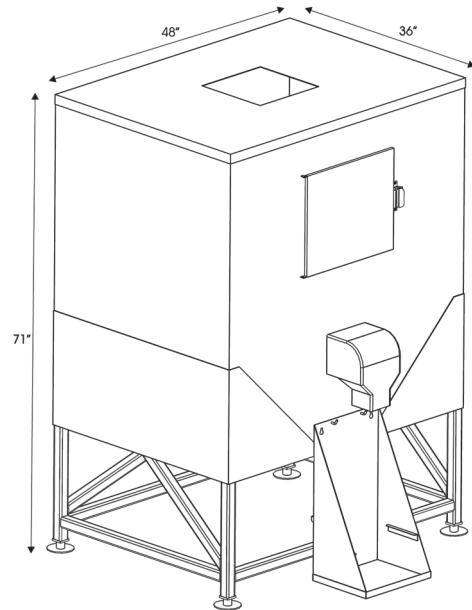

HCD-1000B

### ELECTRICAL & PLUMBING / HCD-500/1000B

• 115V/60/1



© HOSHIZAKI AMERICA, INC.

618 Hwy. 74 S., Peachtree City, GA 30269

TEL 1-800-438-6087

FAX 1-800-345-1325

www.hoshizaki.com

Printed in U.S.A.

