



Stock Pot Range

Standard Features

- Stainless steel front, sides and cabinet base
- Three-ring burner with two adjustable gas valves provides flexibility and maximum 70,000 BTU/hr
- Burner is equipped with two continuous pilots for instant ignition
- Roll front is easy to load and gradual slope design reduces spill over
- Heavy-duty cast iron top grate removes easily for cleaning
- Durable stainless steel cabinet base provides additional storage
- Chrome plated 6" legs with adjustable feet
- Shipped with L.P. orifice kit for field conversion
- One year parts and labor warranty

Stock Pot Range features stainless steel front, sides and cabinet base. It has durable, cool to the touch knobs and a heavy-duty top grate. Equipped with a 70,000 BTU burner and heavy-duty castings, with a sloping design to prevent spills.



CPG-SP-18-2
351CPGSP182

Options & Accessories

- Quick disconnect and flexible gas hose

Applications

Soups; Sauces; Stocks; Pasta; Schools; Contract Feeders

Certifications





Stock Pot Range

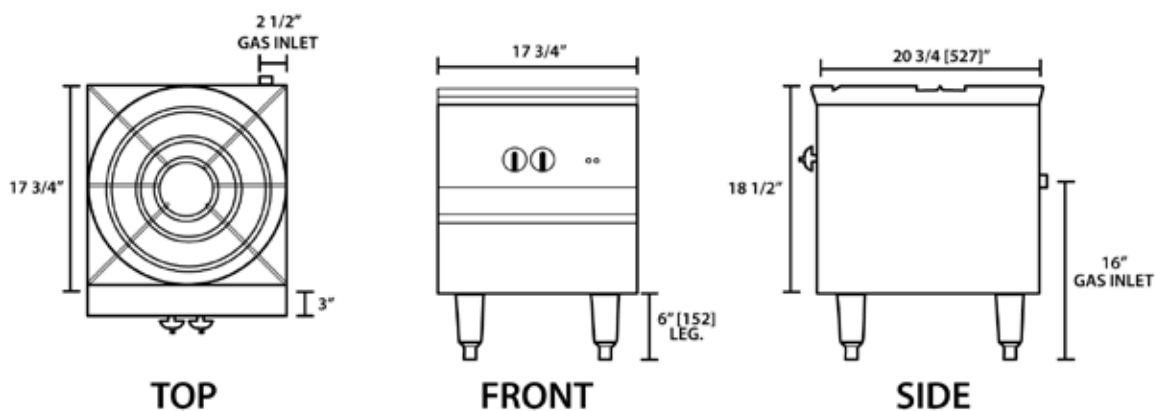

PRODUCT SPECIFICATIONS

Clearance:

Provide 0" clearance from non-combustible surfaces, 10" from sides and rear from combustible surfaces.

Gas Information:

Manifold pressure is 5.0"W.C. for natural gas or 10.0" for propane gas. Manifold size is 3/4" NPT. 3/4" pressure regulator supplied with equipment to be installed at time of connection.

Shipped with orifice kit for field conversion.

CPG-SP-18-2: 17 3/4"W x 20 3/4"D x 24 1/2"H;
3 Ring, 2 Valves; 70,000 BTU, 130 Lbs

Freight Class: 85

