



D45 and DB90S

Ice Dispensers



D45 Features

- Gravity ice dispensing with positive shut-off
- Dispenses all types of cracked or cubed ice
- Fully insulated one-piece thermoformed plastic storage hopper
- Insulated drip tray
- Environmentally safe foam insulation
- Stainless steel construction
- Built to last



DB90S Features

- Takes up only 16" (406 mm) of counter space
- Reliable ice dispensing performance
- Dispenses all types of cracked or cubed ice
- One-piece impact resistant, thermoformed ABS ice storage hopper
- Access to serviceable parts from front of unit
- Fully insulated one-piece ice storage hopper
- All stainless steel exterior construction
- Built to last



D45 and DB90S

Technical Specifications

Ice Storage Capacity

D45: 45 lbs. (20 kgs.)

DB90S: 90 lbs. (41 kgs.)

Drain Connections

D45: 3/4" (19 mm) I.D.

DB90S: 7/8" (22 mm) I.D.

Electrical Requirements 115V / 1A / 60Hz

Shipping Weight

D45: 67 lbs. (31 kgs.)

DB90S: 120 lbs. (54 kgs.)

Electrical Connection 6' (1.82 meters) power cord with 125V / 15 amp 3 prong ground plug

Agency Listings

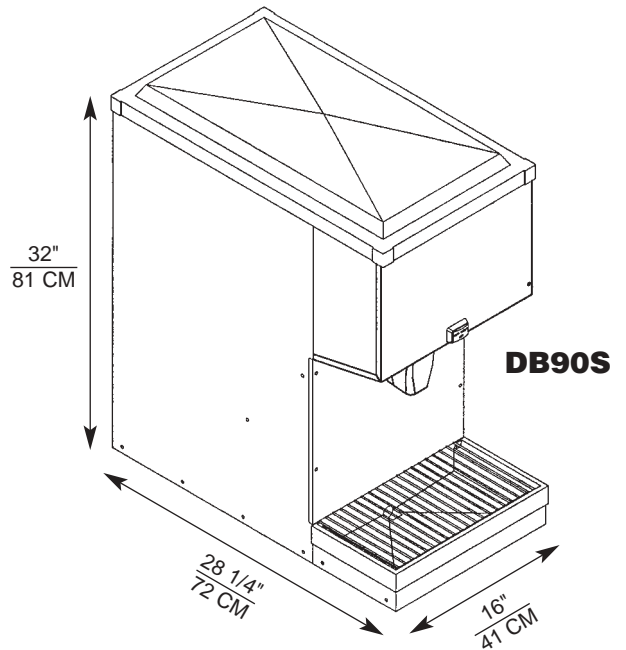
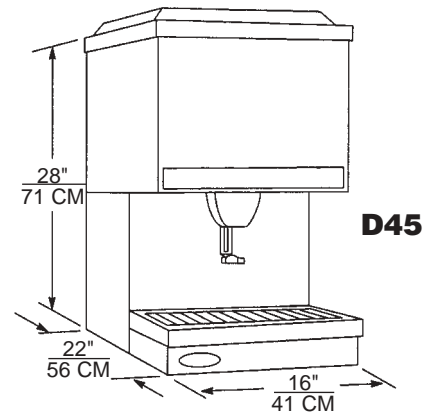

Part No.	Description
01601	D45 Ice dispenser, stainless steel exterior
02644	DB90S Ice dispenser, stainless steel exterior



For more information or to place an order, contact your sales representative or authorized distributor.

In the US:

Phone: 1-800-238-3600

Fax: 1-800-535-4235

Outside the US:

Phone: 1-763-421-6120

Fax: 1-763-422-3297

IMI Cornelius Inc.

One Cornelius Place
Anoka, MN 55303-6234
USA