



NEW! SIGNATURE

FROZEN BEVERAGE / DESSERT DISPENSER



FEATURES

Flexible – Broad capability to sell all the drinks consumers want; frozen beverages, shakes, smoothies, coffees/lattes, lemonade, frozen cocktails, etc.

High capacity refrigeration system – Sell more drinks with industry leading capacity to meet peak demand while maintaining drink quality and consistency

Setting accuracy – Unmatched store-to-store drink profile consistency with electronic controls versus electromechanical controls

Consistent drink profile – Viscosity torque sensing satisfies every customer with the right drink quality, encouraging repeat sales across all your locations

Dual dispense option – Expand menu offering by serving both frozen and chilled beverages from one machine

Small footprint – No side clearance requirement means equipment is easy to add to your current operation

Easy to clean – Up to 50% faster to clean with minimal small parts

Minimal waste – Waste reduced with visible hopper, auger, and refrigeration control design

Intuitive interface – Allows store operator to quickly make adjustments

Reduced PM schedule – No rear barrel seal and no side louvers

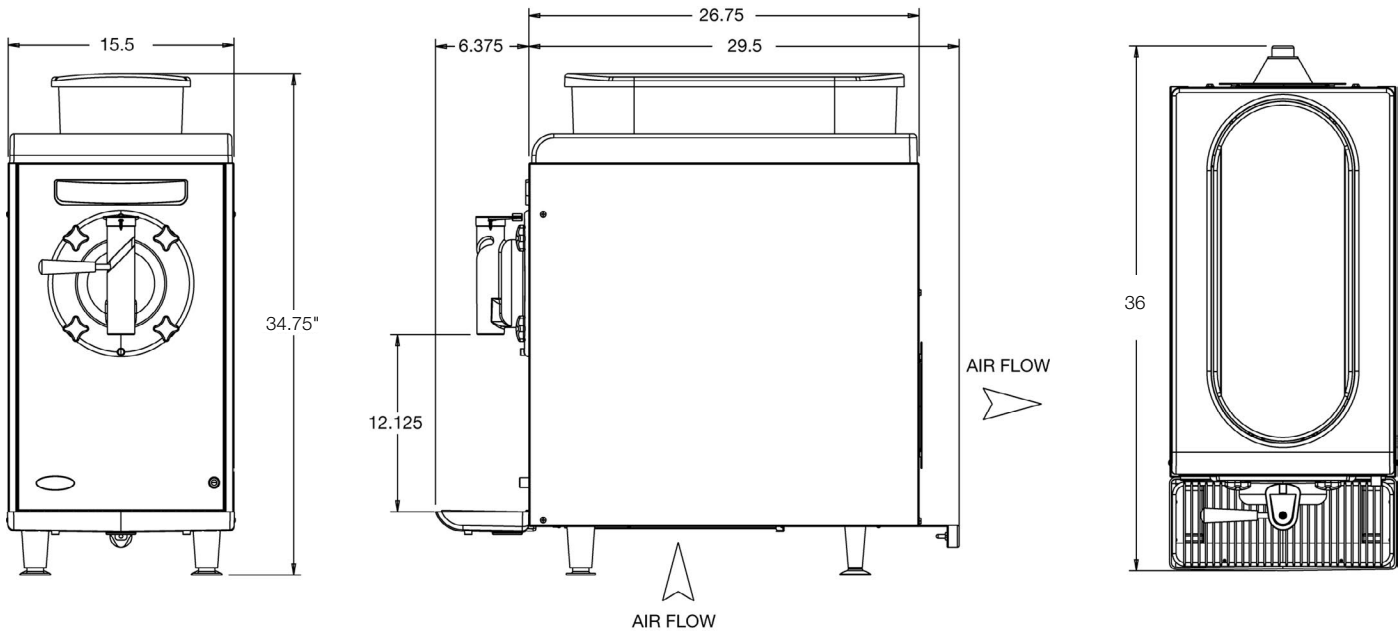

MODELS

PART NUMBER	DESCRIPTION
621058436	Signature 1 flavor, dairy capable, 115v/60Hz
621058437	Signature 1 flavor, dairy capable, 230v/50Hz
621058438	Signature 1 flavor, with dual dispense chilled dispense option (for shelf stable products only), 115v/60Hz
621058439	Signature 1 flavor, with dual dispense chilled dispense option (for shelf stable products only), 230v/50Hz

TECHNICAL SPECIFICATIONS

ELECTRICAL RATINGS 115v/60Hz, 20A, single phase with hard wired power cord.
 230v/50Hz, 15A, single phase with interchangeable IDC connector

REFRIGERATION 3/4Hp, 5400 BTU/hr, R404 refrigerant

FREEZE CYLINDER 1 gallon (4 liters)

MIX HOPPER 3.2 gallons (12 liters)



UNIT DIMENSIONS 15.5" W, 36" D, 34.75" H (394mm, 914mm, 883mm)

MINIMUM CLEARANCE REQUIRED 3" in back with spacer

NET WEIGHT 215 lbs (97.5 kgs)

SHIPPING WEIGHT 250 lbs (113 kgs)

WARRANTY 1 year parts

AGENCY LISTINGS   



IN THE U.S.A.
 Ph: 800.238.3600
 Fax: 800.258.0255

OUTSIDE THE U.S.A.
 Ph: 763.488.8200
 Email: webmaster@cornelius.com

101 Broadway Street West
 Osseo, MN 55369
 www.cornelius.com