



# BEVERAGE-AIR

3779 Champion Blvd., Winston-Salem, NC 27105  
1-888-845-9800 Fax# 1-336-245-6453  
http://www.Beverage-Air.com

**CUSTOMER'S CHOICE FOR A HOT LOCATION**  
**Tested & Certified to Ambient Class of 100°F**

Item No. \_\_\_\_\_  
Quantity \_\_\_\_\_

**PASS-THRU SLIDING  
GLASS DOOR LUMAVUE™  
MERCHANDISER SERIES**  
LV17-54

**MODELS:**  
LV17-1-B-54  
LV17-1-W-54

## 3 Year Parts/Labor Warranty Additional 2 Year Compressor Warranty

### LUMAVUE SERIES—PASS-THRU GLASS DOOR MERCHANDISER

Used for merchandising and storage of product.

#### CABINET CONSTRUCTION

Heavy duty construction includes white coated steel interior walls. Exterior finish is heavy-duty steel with a baked on durable coating. Choose from black or white finish.

Foamed-in-place CFC and HCFC-free polyurethane insulation enhances the structural strength of the cabinet and helps increase energy efficiency.

Modern, one-piece grille is easily removed for cleaning and servicing.

Double pane, lowE argon filled glass doors feature inside and outside panes that are tempered for added safety.

Two sliding glass doors (front and back) feature integral low profile door handles that are more aesthetically pleasing.

Hold-open feature is standard.

Pass-thru configuration.

Four white epoxy coated steel shelves are standard.

#### REFRIGERATION

Whisper-quiet refrigeration system uses R134a refrigerant, which is CFC and HCFC-free for compliance with environmental safety concerns.

Product temperatures from 32°F to 40°F.

#### ELECTRICAL

Interior fluorescent lighting enhances product illumination.

Units wired at factory and ready for connection to a 115/60/1 phase, 15 amp dedicated outlet. 8' long cord and plug set included.



**LV17-1-B-54**

#### SPECIAL FEATURES

- Pass-Thru configuration
- Whisper-quiet refrigeration system
- Sliding glass doors
- 2010 Federal Energy Compliant
- Gravity Flo kits, Bev-Trac and Can Roller options available

#### ELECTRICAL CONNECTION



115/60/1  
NEMA-5-15P

Units pre-wired at factory and include 8' long cord and plug set.

Available From:



\*Note: Not all markings may apply to all model variations.

|                              |                       |
|------------------------------|-----------------------|
| <b>Model Specified</b> _____ | <b>Store#</b> _____   |
| <b>Location</b> _____        | <b>Quantity</b> _____ |



**LumaVue Pass-Thru Glass  
Door Merchandisers  
Model: LV17-54**

|  |                 |
|--|-----------------|
| <b>MODEL</b>   | LV17-54         |
| <b>EXTERNAL DIMENSIONAL DATA</b>                                 |                 |
| Length Overall (inches)<br>Length Overall (mm)                   | 36"<br>914      |
| Depth Overall (inches)<br>Depth Overall (mm)                     | 24"<br>610      |
| Height Overall— (inches)<br>Height Overall— (mm)                 | 60"<br>1524     |
| Number of doors  | 4               |
| <b>INTERNAL DIMENSIONAL DATA</b>                                 |                 |
| NET Capacity (cubic ft.)<br>NET Capacity (Liters)                | 17.5<br>481     |
| Internal Length Overall (inches)<br>Internal Length Overall (mm) | 33"<br>838      |
| Internal Depth Overall (inches)<br>Internal Depth Overall (mm)   | 21"<br>533      |
| Internal Height Overall—(inches)<br>Internal Height Overall—(mm) | 46 7/8"<br>1190 |
| Number of shelves  | 4               |
| <b>ELECTRICAL DATA</b>   |                 |
| Full Load Amperes 115/60/1                                       | 6.2 A           |
| <b>REFRIGERATION DATA</b>  |                 |
| Horsepower   | 1/3             |
| <b>WEIGHT DATA</b>   |                 |
| Gross Weight (Crated lbs)  | 400             |
| Gross Weight (Crated kg)   | 182             |

**PLAN VIEWS**

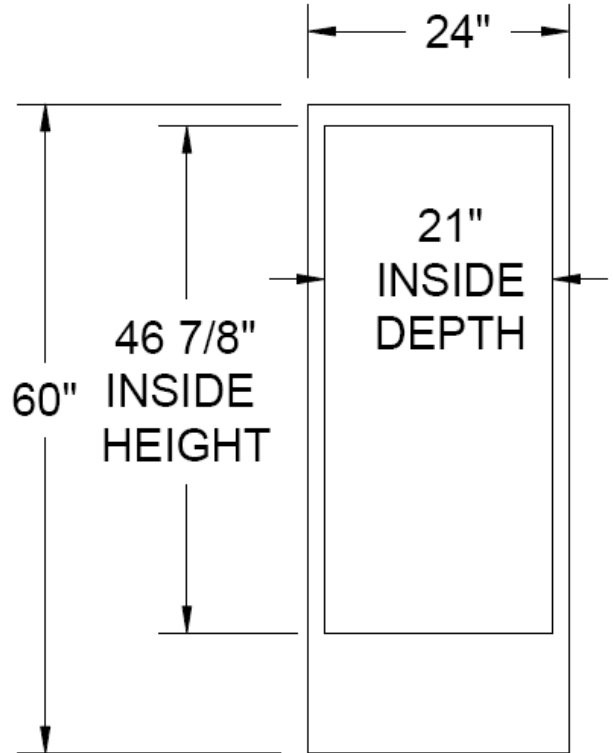

**END**

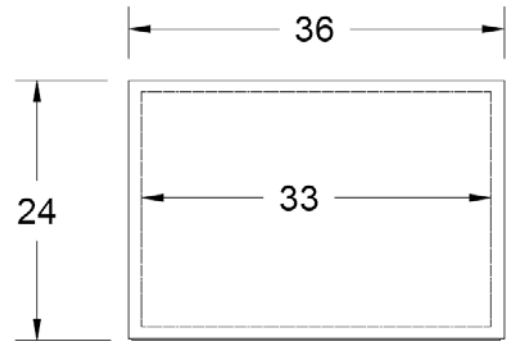

**TOP**



**Note:** Not all markings may apply to all model variations.

**BEVERAGE-AIR® CORPORATION**

3779 Champion Blvd. • Winston-Salem, NC 27105 USA • (336) 245-6400 • Fax (336) 245-6453 • (888) 845-9800 • www.beverage-air.com

Specifications are subject to change without prior notice. 06/13