

TUC Series

Undercounter Refrigerators / Freezers



Both durable and compact, the TUC Series of undercounter refrigerators and freezers keep refrigerated or frozen ingredients right where you need them in prep or server's areas. An enhanced cold air circulation system, coupled with a high quality stainless steel interior and exterior makes the TUC Series the best undercounter refrigerators and freezers on the market.



- High quality stainless steel interior & exterior
- Foamed-in-place high density polyurethane cell insulation
- Self closing doors
- ETL Safety & Sanitation Approved



Features

- 304 series stainless steel interior
- 430 series stainless steel exterior
- Recessed handles
- 2 plastic coated steel shelves included
- Foamed in place polyurethane insulation
- Removable door gasket for easy cleaning
- Self closing doors
- Automatic defrosting
- 4 casters - 2 locking
- ETL Sanitation Listed

Technical Data

Dimensions

Exterior Dimensions (W x D x H)	47" x 30" x 35.25"
Interior Dimensions (W x D x H)	42.5" x 22.75" x 23.5"
Net Volume (cu. ft.)	11.9 cu. ft.
Net Weight	158.5 lbs.
Packaging Dimensions (W x D x H)	49.5" x 31.75" x 36.25"

Cooling

Temperature Range	32° - 41° F
Refrigerant	R134a
Maximum Ambient Temperature Rating	90° F
Defrosting	Automatic
Temperature Display	No
Temperature Controller	Mechanical
Horsepower	1/4

Construction

Exterior Material	430 Series Stainless Steel
Interior Material	304 Series Stainless Steel
Insulation Material	Foamed in Place Polyurethane
Shelf Material	Plastic Coated Steel
Shelf Load Capacity	90 lbs.

Electrical

Voltage	120
Amps	4.8
Hz	60
Phase	1
Electrical Cord Length	84"

Keep more of your most-used ingredients on hand and make use of that space under your countertop with this Avantco TUC48R double door undercounter refrigerator! Ideal for snack bars, concession stands, pizzerias, sandwich shops, and even break rooms, this unit provides 11.9 cubic feet of refrigerated storage space in a compact, 48" wide footprint. And since it comes mounted on casters (2 locking), you can easily place it underneath any countertop with adequate ventilation clearance.

A corrosion-resistant 304 stainless steel interior also makes it easy to clean and ensures you'll never be set back by spills, while two adjustable plastic coated steel shelves let you adapt to changing menu needs.

The rear and side-breathing refrigeration system is centered around a 1/4 hp compressor and foamed-in place polyurethane insulation to ensure efficient operation, and a top mounted cooling fan ensures even temperatures throughout the interior, even when the door is opened. Please consult the Specification Sheet for additional details.

Plan View

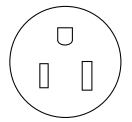
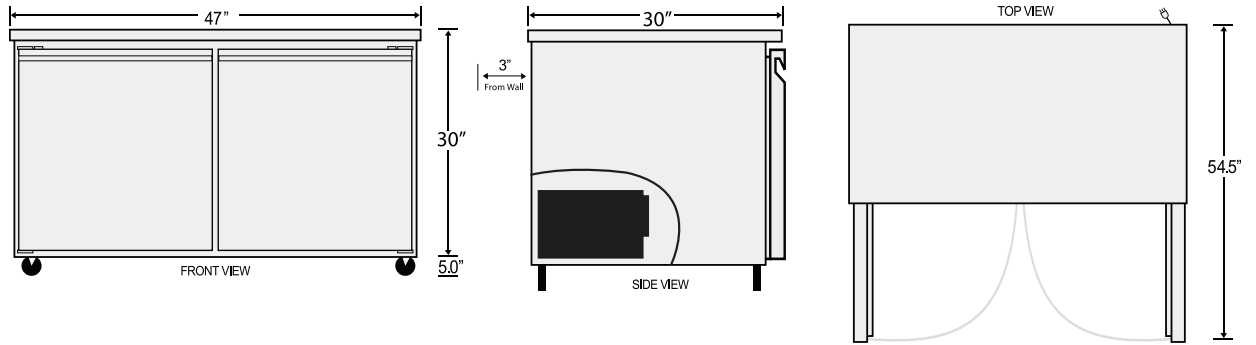

NEMA 5-15P



All Avantco Refrigerators and Freezers are backed by a 1 year parts and labor warranty, with a 5 year warranty on the compressor. For warranty inquiries or service, first locate the serial number plate on the front of the unit, or inside the door jamb. Next, call 1-800-678-5517. Be sure to have the serial and model numbers available when contacting service technicians.