

TUC Series

Undercounter Refrigerators / Freezers



Both durable and compact, the TUC Series of undercounter refrigerators and freezers keep refrigerated or frozen ingredients right where you need them in prep or server's areas. An enhanced cold air circulation system, coupled with a high quality stainless steel interior and exterior makes the TUC Series the best undercounter refrigerators and freezers on the market.



- High quality stainless steel interior & exterior
- Foamed-in-place high density polyurethane cell insulation
- Self closing doors
- ETL Safety & Sanitation Approved

Features

- 304 series stainless steel interior
- 430 series stainless steel exterior
- Recessed handles
- 2 plastic coated steel shelves included
- Foamed in place polyurethane insulation
- Removable door gasket for easy cleaning
- Self closing doors
- Automatic defrosting
- 4 casters (two locking)
- ETL Sanitation Listed

Technical Data

Dimensions

Exterior Dimensions (W x D x H)	47" x 30" x 35"
Interior Dimensions (W x D x H)	42.5" x 22.75" x 23.5"
Net Volume (cu. ft.)	11.9 cu. ft.
Net Weight	158.5 lbs.
Packaging Dimensions (W x D x H)	49.5" x 31.75" x 36.25"

Cooling

Temperature Range	32° - 50° F
Refrigerant	R134a
Maximum Ambient Temperature Rating	100.4° F
Defrosting	Automatic
Temperature Display	No
Temperature Controller	Mechanical
Horsepower	1/4

Construction

Exterior Material	430 Series Stainless Steel
Interior Material	304 Series Stainless Steel
Insulation Material	Foamed in Place Polyurethane
Shelf Material	Plastic Coated Steel
Shelf Load Capacity	90 lbs.

Electrical

Voltage	120
Amps	4.8
Hz	60
Phase	1
Electrical Cord Length	84"



With its compact size and all stainless steel interior and exterior, this double door undercounter refrigerator is a perfect addition to snack bars, concession stands, pizzerias, sandwich shops, and restaurant kitchens with limited space. Built in casters, two of which are locking, allow you to pull the refrigerator out from under your countertops, for easy cleaning and service.

Two plastic coated steel shelves are included. Adjustable mounting brackets give you complete control over the refrigerator's shelving configuration, to accommodate a variety of toppings, garnishes, or condiments.

The 48" undercounter refrigerator's 1/4 hp compressor uses R134a refrigerant. Foamed in place polyurethane cell insulation helps maintain interior temperatures between 32° and 50° Fahrenheit. A top mounted cooling fan circulates air quickly throughout the refrigerator, regulating the internal temperature even when the refrigerator's self-closing doors are opened.

With its durable, 430 series stainless steel exterior and 304 series stainless steel interior, the double door undercounter refrigerator is strong enough to stand up to the daily demands of your busy restaurant kitchen. The double door undercounter refrigerator has a 120V, 4.8 amp, 60 Hz. electrical rating, and is ETL Sanitation Listed and NSF Compliant.

Plan View

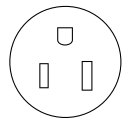
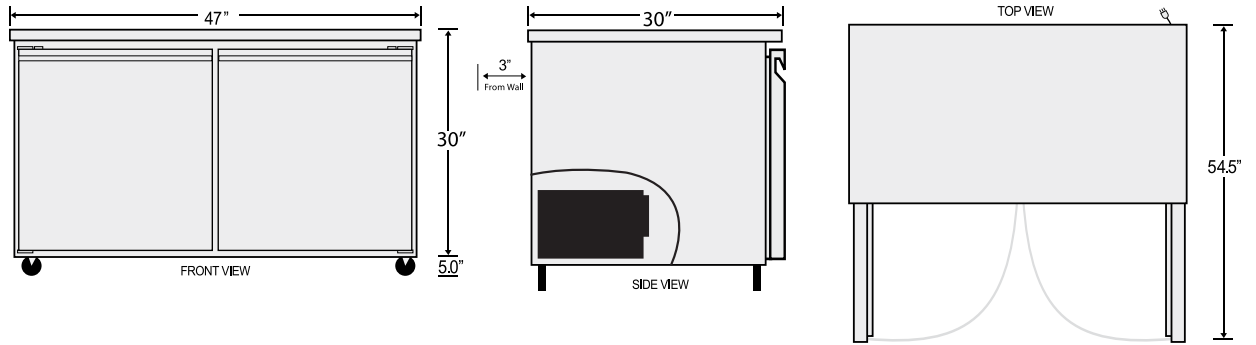

NEMA 5-15P



1 year
WARRANTY

Parts & Labor



5 year
WARRANTY

Compressor

All Avantco Refrigerators and Freezers are backed by a 1 year parts and labor warranty, with a 5 year warranty on the compressor. For warranty inquiries or service, first locate the serial number plate on the front of the unit, or inside the door jamb. Next, call 1-800-678-5517. Be sure to have the serial and model numbers available when contacting service technicians.