

SCL Series



Sandwich/Salad Prep Refrigerators



- Insulated lid for superior cold retention
- Full length cutting boards (various depths)
- Refrigerated cabinet base for added cold storage
- 430 Series stainless steel exterior, door and sides stand up to the rigors of day-to-day use
- 304 Series, corrosion-resistant stainless steel interior
- Includes (4) casters, (2) locking for stability
- Adjustable shelf/shelves included
- ETL Safety and ETL Sanitation Listed. NSF Compliant

178SCL236 - 36" Sandwich/ Salad Prep Refrigerator



Product Features

- Full length, 10 1/2" deep cutting board
- Top holds up to (10) 1/6 size food pans up to 6" deep
- Insulated lid for better temperature retention
- (2) Self closing swing doors with recessed handle
- Refrigerated base with (2) adjustable shelves included
- Stainless steel door, sides and interior
- Includes (4) casters; (2) locking
- Temperature range of 32°F - 41°F
- ETL Safety and ETL Sanitation Listed

Technical Data

Dimensions

Exterior Dimensions	36 1/4"W x 31"D x 42 1/2"H
Interior Dimensions	32"W x 23 3/4"D x 23 1/2"H
Cutting Board Dimensions	36"W x 10 1/2"D x 3/4"H
Net Volume (internal)	9 cu. ft.
Net Weight	218 lbs.
Pan Capacity (6" deep)	Up to (10) 1/6 size
Packaging Dimensions	41 1/2"W x 34 3/4"D x 46"H

Cooling

Temperature Range	32° - 41°F
Refrigerant	R-134a
Max. Ambient Temperature	90°F
Defrosting	Automatic
Temperature Controller	Digital
Horsepower	1/4

Construction

Exterior Material	430 Series stainless steel
Interior Material	304 Series stainless steel
Insulation Material	Foamed in place polyurethane
Number of Doors	2
Number of Shelves	2
Shelf Material	Plastic coated steel
Shelf Load Capacity	90 lbs.

Electrical

Voltage	120
Amps	4.6
Hz	60
Phase	1
Plug Type	NEMA 5-15P
Electrical Cord Length	84"

If your restaurant prides itself on making top-notch subs and sandwiches, the Avantco SCL2-36 is the perfect prep table for you, boasting convenient ingredient storage and ample prep space for your culinary creations! This 36" unit features a top that can hold up to (10) 1/6 size food pans full of your most commonly used meats, cheeses, and toppings, and an insulated lid to keep in cold temperatures when not in use. A 10 1/2" deep cutting board gives you plenty of space to assemble subs, salads, and hoagies, while the exterior sides and door of the unit are made from 430 stainless steel to stand up to the rigors of day to day use.

To help you spend more time at the prep line, the refrigerated cabinet base below the work area gives you room to store extra ingredients, garnishes, condiments, or topping pans, and it is made of 304 stainless steel to resist corrosion and make cleaning a breeze. Two adjustable plastic coated shelves, each with a 90 lb. capacity, also help you stay organized.

Additional features include an interior fan that directs cold air up to the topping area, self-closing doors with removable gaskets, a 32-41 degrees Fahrenheit temperature range with digital temperature controls, and an automatic defrosting mechanism. The 1/4 hp compressor is run with CFC-free R-134a refrigerant, and 4 included casters provide easy mobility. Pan divider bars for the top are also included. This unit is NSF compliant and requires a 120V electrical connection.

178SCL236 - 36" Sandwich/ Salad Prep Refrigerator



www.AvantcoRefrigeration.com

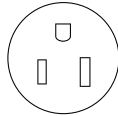

NEMA 5-15P

Plan View

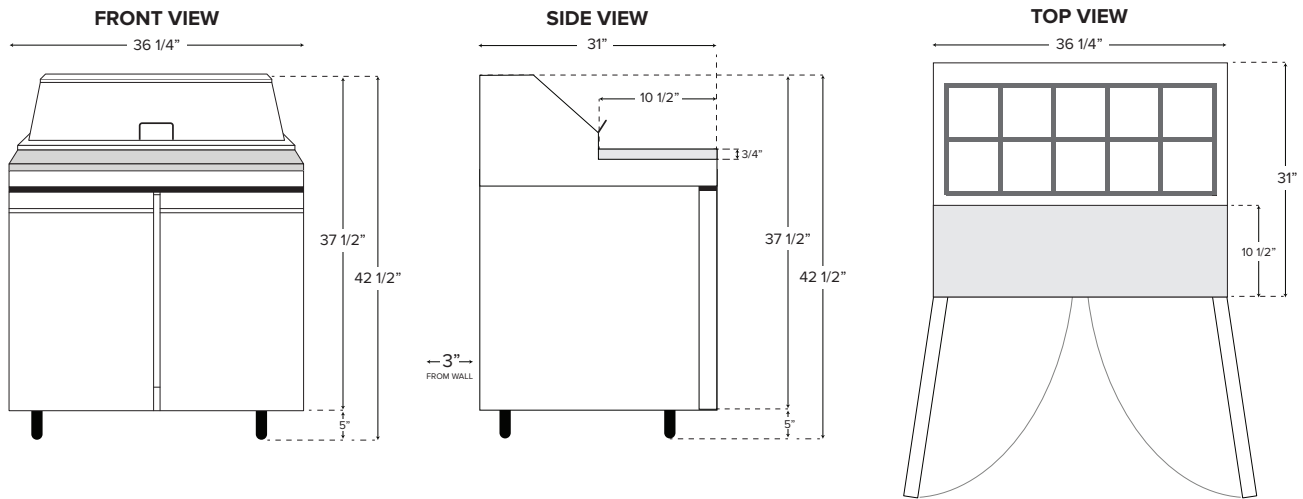

Warranty Information

This item is backed by a 1 year parts and labor warranty with 5 year warranty on the compressor, unless otherwise stated. For warranty inquiries or service, first locate the model number (located on the front of the unit, or inside the door jamb) and the bold number on the service plate (located on the front of the unit). Next, call 1-800-678-5517. You must have the model number and service plate number when contacting service technicians.



Parts & Labor



Compressor

Failure to contact Avantco Refrigeration prior to obtaining equipment service may void your warranty.

Avantco Refrigeration will not warrant coverage for component failure or other damages that arise under the following conditions:

- Failure to install and/or use unit within proper operating conditions specified by Avantco Refrigeration
- Failure to properly maintain the unit. This includes, but is not limited to, basic preventative maintenance such as cleaning the condenser coil.
- Installation in a non-commercial or residential application
- Products sold or used outside of the United States

Additionally, no claims can be made against this warranty for spoilage of product, loss of sales or profits, or any other consequential damages.

Normal wear type parts, such as light bulbs and gaskets, are not included in warranty coverage.