



Features

- R134a refrigerant
- Embossed aluminum interior
- Lid lock
- Drain plug
- 1 basket included (16" x 10" x 7.5")
- Interior lighting
- CE Listed, 120V

Technical Data

Exterior Dimensions (W x D x H)	41.5" x 21.5" x 32"
Interior Dimensions (W x D x H)	38" x 18" x 23.75"
Net Volume (cu. ft.)	9 cu. ft.
Power Consumption (kwh/24h)	1.3
Net Weight (lbs.)	102

This Avantco 9 cubic foot commercial chest freezer is perfect for storage of bulk food items at your convenience store, ice cream shop, restaurant, or market! Its durable, white powder coated finish is easy to clean and will provide years of dependable service. Thick wall insulation plus a R134a refrigeration system allow this commercial chest freezer to easily maintain operating temperature of 0 degrees Fahrenheit.

A drain plug allows for easy cleaning and manual defrosting, while four easy-to-install casters enhance the freezer's mobility. A lid lock is included for security. This 9 cubic foot Avantco chest freezer is CE Listed and requires a 120V electrical connection.

Plan View

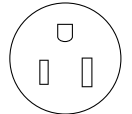
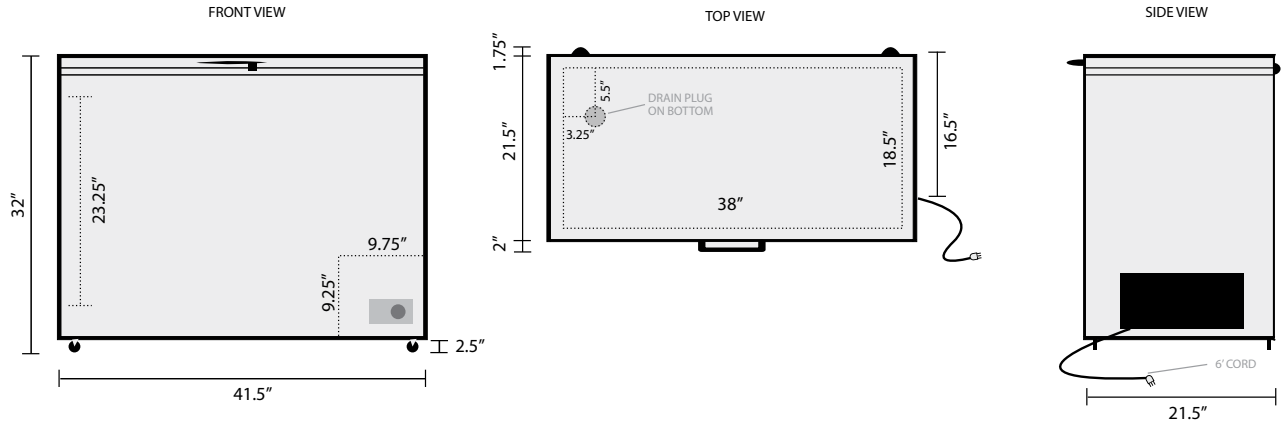

NEMA 5-15P



Parts & Labor

Avantco Chest Freezers are backed by a 1 year parts and labor warranty. For warranty inquiries or service, first locate the serial number plate on the front of the unit, or inside the door jamb. Next, call 1-800-678-5517. Be sure to have the serial and model numbers available when contacting service technicians.