

HF Series

Commercial Chest Freezers



- Perfect storage for bulk food items
- Durable, white powder coated exterior
- Plastic coated basket(s) help keep items organized
- Built-in compressor with R-134a refrigerant maintains operating temperatures of -13°F to 0°F
- Drain plug allows for easy cleaning and manual defrosting
- Four casters for enhanced mobility
- CE listed

178HF5 - 5.2 Cu. Ft. Commercial Chest Freezer



Product Features

- 5.2 cu. ft. of bulk food storage space
- (1) Insulated lid for better temperature retention
- Durable, white powdered coated exterior
- Embossed aluminum interior
- (1) Coated wire basket for added storage and organization
- Drain plug for easy cleaning and self-defrosting
- Includes (4) casters
- Temperature range of -13°F to 0°F

Technical Data

Dimensions

Exterior Dimensions	32 ½"W x 19"D x 33 ½"H (includes 2 ½" casters)
Interior Dimensions	24 ½"W x 14"D x 27"H
Net Volume (internal)	5.2 cu. ft.
Net Weight	79 lbs.
Packaging Dimensions	35"W x 22 ¾"D x 34 ½"H

Cooling

Temperature Range	-13° to 0°F
Refrigerant	R-134a
Max. Ambient Temperature	90°F
Defrosting	Manual
Temperature Display	Yes
Temperature Controller	Manual (0-7 scale)

Construction

Number of Doors	1
Exterior Material	White powder coated steel
Interior Material	Embossed aluminum
Insulation Material	Foamed in place polyurethane
Number of Baskets	1
Basket Dimensions	10 ½"W x 12 ¼"D x 7 ¼"H
Basket Material	Plastic coated wire
Drain Plug	Located at back left

Electrical

Voltage	110
Wattage	112
Amps	1.2
Hz	60
Phase	1
Plug Type	NEMA 5-15P
Electrical Cord Length	75"

This Avantco HF5 5.2 cu. ft. commercial chest freezer is perfect for storage of bulk food items at your convenience store, ice cream shop, restaurant, or market! Its durable, white powder coated finish is easy to clean and will provide years of dependable service. A basket is included to help keep items organized. Thick wall insulation and a R-134a refrigeration system ensure that this commercial chest freezer will easily maintain operating temperatures of -13 to 10 degrees Fahrenheit. An easy-to-use dial on the bottom of the outside of the chest controls temperature, while "running" and "power" indicator lights tell you the status of the machine.

A drain plug allows for easy cleaning and manual defrosting, while four easy-to-install casters enhance the freezer's mobility. This 5.2 cu. ft. Avantco chest freezer requires a 110V electrical connection.

178HF5 - 5.2 Cu. Ft. Commercial Chest Freezer



www.AvantcoRefrigeration.com

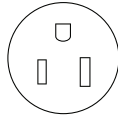

NEMA 5-15P

Plan View

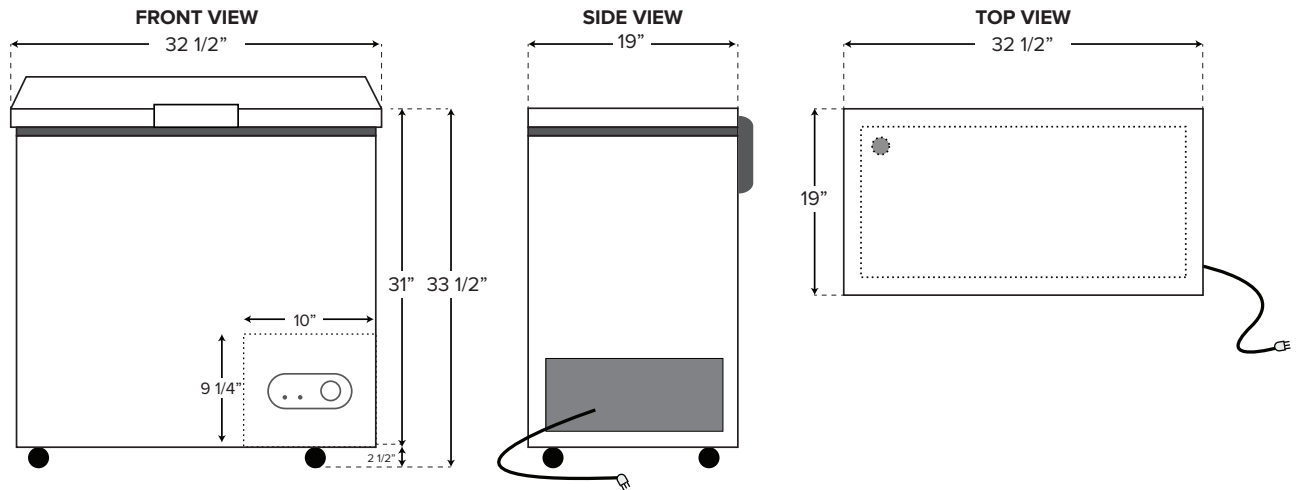

1 Year Limited Replacement Warranty

Unless otherwise stated, Avantco Refrigeration warrants to the original purchaser of new, qualified Avantco Refrigeration units (and all parts thereof), that such equipment will be free from defects in material and workmanship for a period of 1 year from the date of delivery. If a qualified product is found to be defective during this period, Avantco Refrigeration will repair the defective unit, replace any defective parts, or replace the defective unit.



Replacement

What This Warranty Does Not Cover:

Avantco Refrigeration will not warrant coverage for component failure or other damages that arise under the following conditions:

- Failure to install and/or use unit within proper operating conditions specified by Avantco Refrigeration
- Failure to properly maintain the unit. This includes, but is not limited to, basic preventative maintenance such as cleaning the condenser coil.
- Products sold or used outside of the United States

Additionally, no claims can be made against this warranty for spoilage of product, loss of sales or profits, or any other consequential damages. Normal wear type parts, such as light bulbs and gaskets, are not included in warranty coverage.

For Warranty Inquiries or Service:

To obtain warranty service, contact the location that you purchased the product from:

www.WebstaurantStore.com:

Call 717-392-7472. You must have your order number ready when contacting.

The Restaurant Store:

If you purchased this unit from your local store location, please contact your store directly. A list of store locations can be found by visiting: <http://www.therestaurantstore.com/store-directory.html>

www.TheRestaurantStore.com:

If you purchased this unit online, call 717-392-7261. You must have your order number ready when contacting.

Failure to contact the designated location prior to obtaining equipment service may void your warranty.