

CFD Series

REFRIGERATION
AVANTCO

Reach In Refrigerator & Freezers



- High quality stainless steel interior and exterior
- Digital temperature controls with LCD Display
- Outstanding temperature preservation and reduced energy consumption
- Durable shelf slides also accept full-size food pans
- ETL Safety & ETL Sanitation Listed

178CFD2RR - Two Section Solid Door Reach-In Refrigerator



Product Features



- 46.5 cu. ft. of interior storage space
- Digital temperature controls with LCD display
- 430 Series stainless steel exterior
- Corrosion resistant 304 stainless steel interior
- (6) Shelves included; versatile shelf slide design also accepts full-size food pans
- Stay-open door with recessed door handle
- Door lock standard
- (4) 5" casters; 2 locking
- Foamed in place polyurethane insulation

Technical Data

Dimensions

Exterior Dimensions	54"W x 32¼"D x 82½"H
Interior Dimensions	49½"W x 27"D x 60¼"H
Net Volume	46.5 cu. ft.
Net Weight	448 lbs.
Packaging Dimensions	56¼"W x 34½"D x 83½"H

Cooling

Temperature Range	32°F - 41°F
Refrigerant	R-134A
Max. Ambient Temperature	90°F
Defrosting	Automatic
Temperature Controller	Digital
Horsepower	1/2

Construction

Exterior Material	430 series stainless steel
Interior Material	304 series stainless steel
Insulation Material	Foamed in place polyurethane
Shelf Material	Plastic coated steel
Shelf load capacity	120 lbs.

Electrical

Voltage	120
Amps	9.4
Hz	60
Phase	1
Plug Type	NEMA 5-15P
Electrical Cord Length	96"

Your establishment relies on refrigeration for proper food safety, and with this Avantco CFD-2RR 54" two section solid door refrigerator, you receive performance you can depend on, along with many innovative standard features to make your kitchen run more smoothly! A 304 series stainless steel interior gives this unit superior corrosion resistance and cleanability, so you're never set back by spills and messes, while a 430 stainless steel door and exterior sides give it a sleek appearance and long lasting durability.

Its bottom mounted refrigeration system allows easier use by raising the height of the bottom shelf so you bend over less during loading and unloading. This design also lets the refrigerator draw in cooler air for more efficient operation, and makes it easier to access the refrigeration system when maintenance is required. Other helpful features include 2 "stay open" doors, door locks, 6 adjustable shelves, and robust shelf slides which allow you to easily swap out the shelves for 12" x 20" food pans when needed.

178CFD2RR - Two Section Solid Door Reach-In Refrigerator



www.AvantcoRefrigeration.com

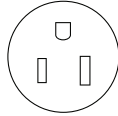

NEMA 5-15P

Plan View

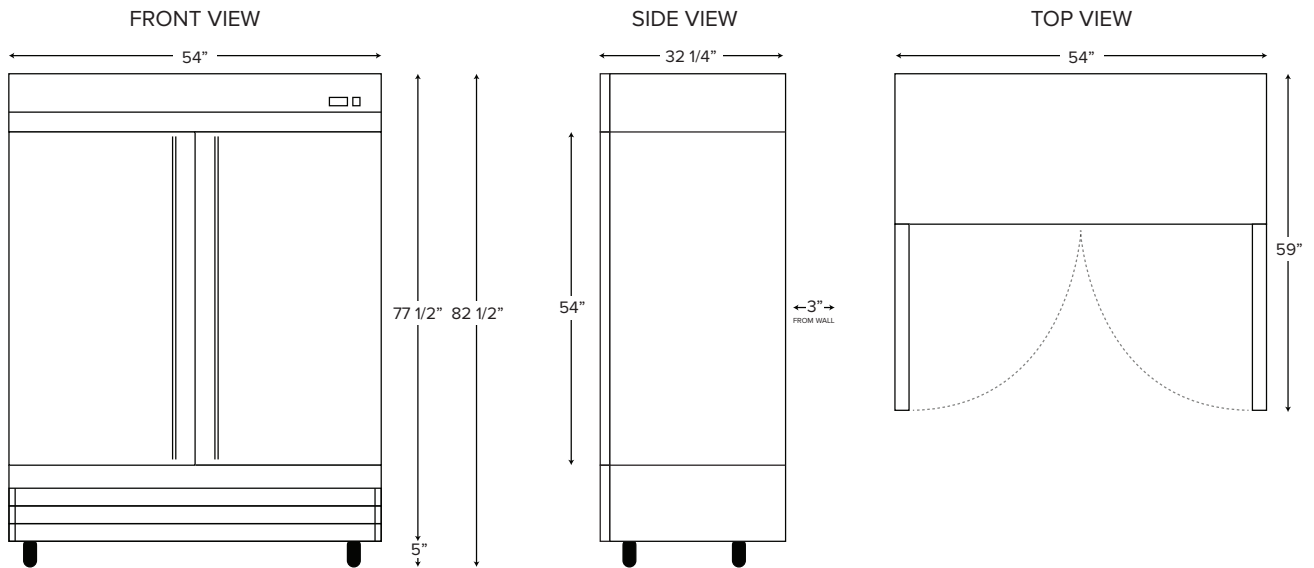

Warranty Information

This item is backed by a 1 year parts and labor warranty with 5 year warranty on the compressor, unless otherwise stated. For warranty inquiries or service, first locate the model number (located on the front of the unit, or inside the door jamb) and the bold number on the service plate (located on the front of the unit). Next, call 1-800-678-5517. You must have the model number and service plate number when contacting service technicians.



Failure to contact Avantco Refrigeration prior to obtaining equipment service may void your warranty.

Avantco Refrigeration will not warrant coverage for component failure or other damages that arise under the following conditions:

- Failure to install and/or use unit within proper operating conditions specified by Avantco Refrigeration
- Failure to properly maintain the unit. This includes, but is not limited to, basic preventative maintenance such as cleaning the condenser coil.
- Installation in a non-commercial or residential application
- Products sold or used outside of the United States

Additionally, no claims can be made against this warranty for spoilage of product, loss of sales or profits, or any other consequential damages.

Normal wear type parts, such as light bulbs and gaskets, are not included in warranty coverage.