

# Arctic Air Commercial Dual-Temp Wine Cellar



*Shown Model DTW100. See back page for specifications.*

DTW100 Wine Cellar features two separate compartments and temperature zones, locks, lights, digital displays, black exterior with stainless steel doors, front venting, sliding shelves, and 100 Bordeaux size bottle capacity.



# It's not only easy to see what's inside— it's easy to see why these are such a great buy.

- Two full-view stainless steel doors with double-pane glass
- 100-bottle capacity (bottles vary in size — capacity may vary slightly)
- Bottles vary in size and capacity
- Two separate compartments
- Individual digital temperature controls and readouts
- Temperature range from +46° to +64°F
- Ideal conditions for red, white and sparkling wines



- Dark grey interior cabinets light up on command
- Slide-out, backstop, chrome-plated racks
- Front-vented for built-in applications
- Fans circulates inside air
- Independent lock and key for each door
- Heavy duty leveling legs

These quiet, economical Arctic Air Wine Cellars come with a full warranty:  
5 years on compressor, 1 year parts and labor.

## MODEL #DTW100 WINE CELLAR

### Capacity:

100 bottles (50 per side)

### Unit Dimensions:

Height 59.8"  
Width 26.0"  
Depth 30.5"

### Unit Weight:

220.4 lbs.

### Electrical Rating:

115 Volt, 60 Hz, 1.6A

### Refrigerant:

R134a

### Shipping Dimensions:

Height 62.6"  
Width 29.9"  
Depth 30.9"

### Shipping Weight:

242 lbs.

© 2008 Broich Enterprises. All rights reserved.

Arctic Air Brand and Logo are registered trademarks of Broich Enterprises.

Products and specifications subject to change without prior written notice.

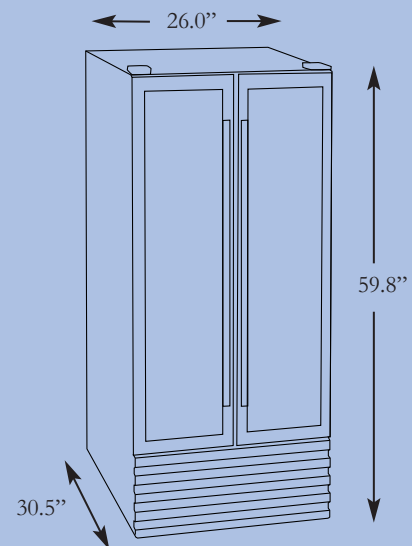

## Use as a free standing cellar or as a built-in!



Commercial Freezers & Refrigerators

Division of Broich Enterprises, Inc. 6440 City West Parkway Eden Prairie, MN 55344  
952-941-2270 Fax: 952-941-3066 www.articairco.com info@articairco.com