

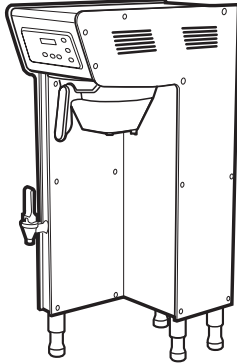

WILBUR CURTIS COMPANY, INC.

Service Manual, Milano Single Head Coffee Brewer



Models Included
◆ TPC2S

IMPORTANT: Equipment to be installed to comply with applicable federal, state, or local plumbing/electrical codes having jurisdiction.

CAUTION: Please use this setup procedure before attempting to use this brewer. Failure to follow the instructions can result in injury or the voiding of the warranty.

CAUTION: DO NOT connect this brewer to hot water. The inlet valve is not rated for hot water.

WARNING TO AVOID SCALDING: Do not remove brewcone while brew light is flashing.



ISO 9001 REGISTERED
WILBUR CURTIS COMPANY
Montebello, CA 90640

Important Safeguards & Symbols

This appliance is designed for commercial use. Any servicing other than cleaning and maintenance should be performed by an authorized Wilbur Curtis service center.

- Do NOT immerse the unit in water or any other liquid
- To reduce the risk of fire or electric shock, do NOT open top or side panels. No user serviceable parts inside. Repair should be done only by authorized service personnel.
- Keep hands and other items away from hot parts of unit during operation.
- Never clean with scouring powders, bleach or harsh implements.

Symbols



WARNINGS – To help avoid personal injury



Important Notes/Cautions – from the factory



Sanitation Requirements

The Curtis Milano Brewer is Factory Pre-Set and Ready to Go... Right from the Carton.

Following are the Factory Settings for your Coffee Brewing System:

- Brew Temperature = 200°F
- Water Bypass = On for LARGE & MEDIUM Brew Only
- Brew Volume = Set to Vessel Requirement.
- Sleep Mode = Off

System Requirements:

- Water Source 20 – 90 PSI (Minimum Flow Rate of 1 GPM)
- Electrical: See attached schematic for standard model or visit www.wilburcurtis.com for your model.

SETUP STEPS

The unit should be level (left to right and front to back), located on a solid counter top. Connect a water line from the water filter to the brewer. NOTE: Some type of water filtration device must be used to maintain a trouble-free operation. (In areas with extremely hard water, we suggest that a sedimentary and taste & odor filter be installed.) This will prolong the life of your brewing system and enhance coffee quality.



NSF International requires the following water connection:

1. A quick disconnect or additional coiled tubing (at least 2x the depth of the unit) so that the machine can be moved for cleaning underneath the unit.
2. This equipment is to be installed with adequate back flow protection to comply with applicable federal, state and local codes.
3. Water pipe connections and fixtures directly connected to a potable water supply shall be sized, installed and maintained in accordance with federal, state, and local codes.

1. A 3/8" NPT x 3/8" Flare elbow has been supplied for water line connection. Use tubing sized sufficiently to provide a minimum of 1.0 GPM.
2. To hookup the InterLock grinder, locate the jack labeled "Class 2 Wiring Only" on brewer and grinder. Connect the two with the cable plug.
3. Connect the unit to an appropriate electrical power circuit.
4. Turn on the toggle (STANDBY/ON) switch behind the unit. The heating tank will start to fill. When the water level in the tank rises to the correct volume, the heating elements will energize automatically. With the G4 system there is no danger of element burnout caused by an empty tank.
5. The heating tank will require 20 to 30 minutes to reach operating temperature (200°F). You will be notified when READY-TO-BREW appears on the control panel LCD screen.
6. Prior to brewing, dispense 12 ounces of hot water through the hot water faucet.
7. Brew a cycle of at least 12 ounces, to purge the water lines of any air that may be trapped after filling.

BREWING INSTRUCTIONS

1. Brewer should be ON (Confirm at rear toggle switch, then press the ON/OFF button). Ready-to-Brew should read on the LCD screen. If connected to an InterLock grinder, grinder should be on. Grind coffee at this time.
2. Place an empty Milano server under the brew cone.

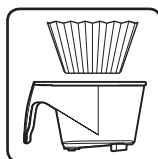

3. Place a new paper filter into the brew cone.



4. Fill the brew cone with correct amount of ground coffee.



5. Slide the filled brew cone to the brew rails.

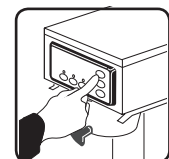

6. Press the brew button to start the brew cycle.

Your Curtis ADS System is Factory Pre-Set for Optimum Performance.

After connection to water and power, the rear toggle switch must be on. You will hear a beep sound, indicating power is available to the controller.

The control displays **CURTIS** Press ON/OFF button and the screen will display **THERMO-PRO CURTIS** After three seconds, **CURTIS FILLING...** is displayed.

Water will fill the tank (approximately 2-3 minutes depending on water flow rate). When the proper level is reached **CURTIS HEATING...** will appear on the screen. It takes approximately 20 minutes to reach setpoint temperature of 200°F.

Control will display **CURTIS READY TO BREW** when temperature reaches the setpoint (200°F). Unit is now ready to brew.

Programming Control Module – Menu Tree

The flow chart displays the sequence of menu items that can be accessed through the UCM.

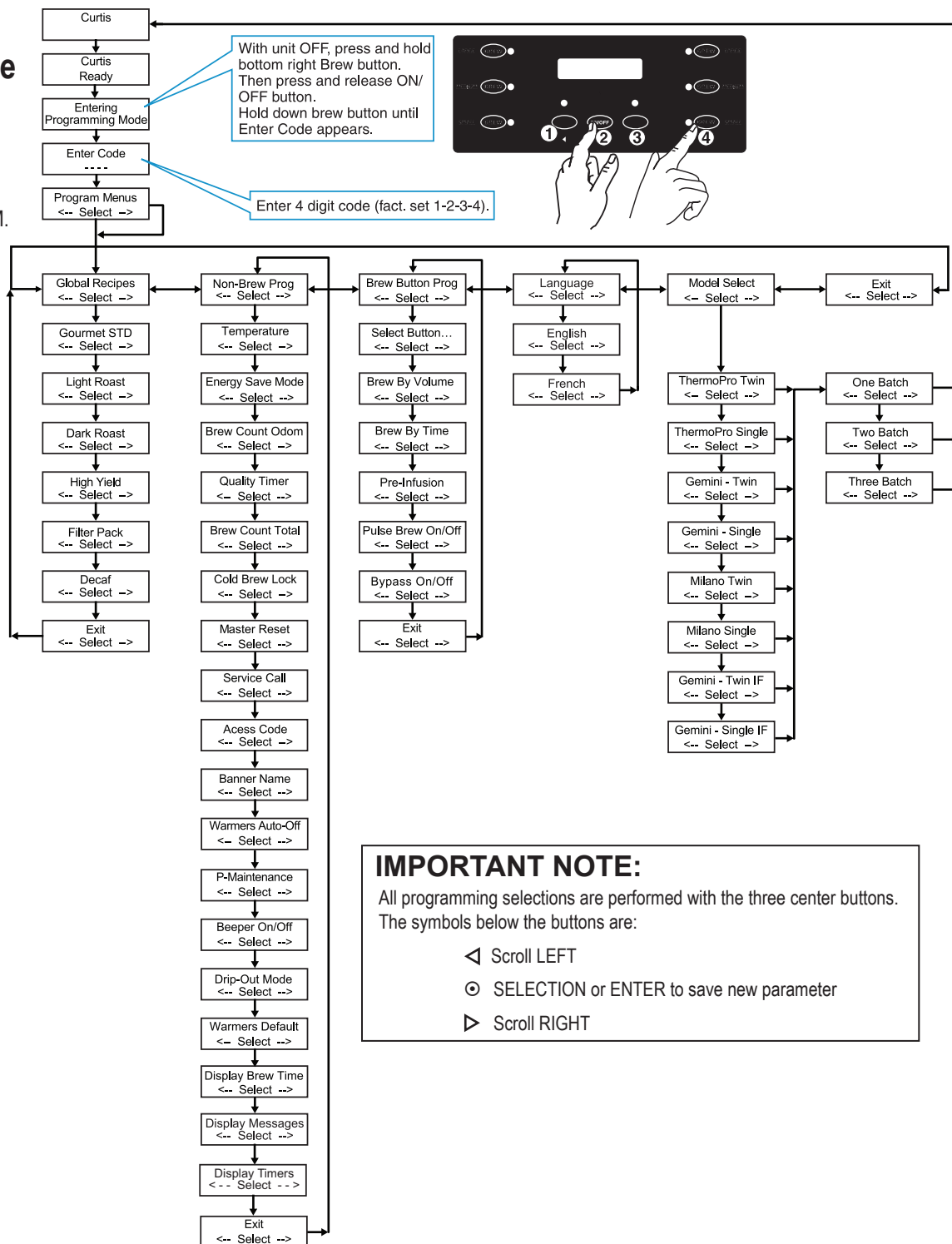

IMPORTANT NOTE:

All programming selections are performed with the three center buttons. The symbols below the buttons are:

- ◀ Scroll LEFT
- ⊙ SELECTION or ENTER to save new parameter
- ▶ Scroll RIGHT

PARTS DIAGRAM
TPC2S

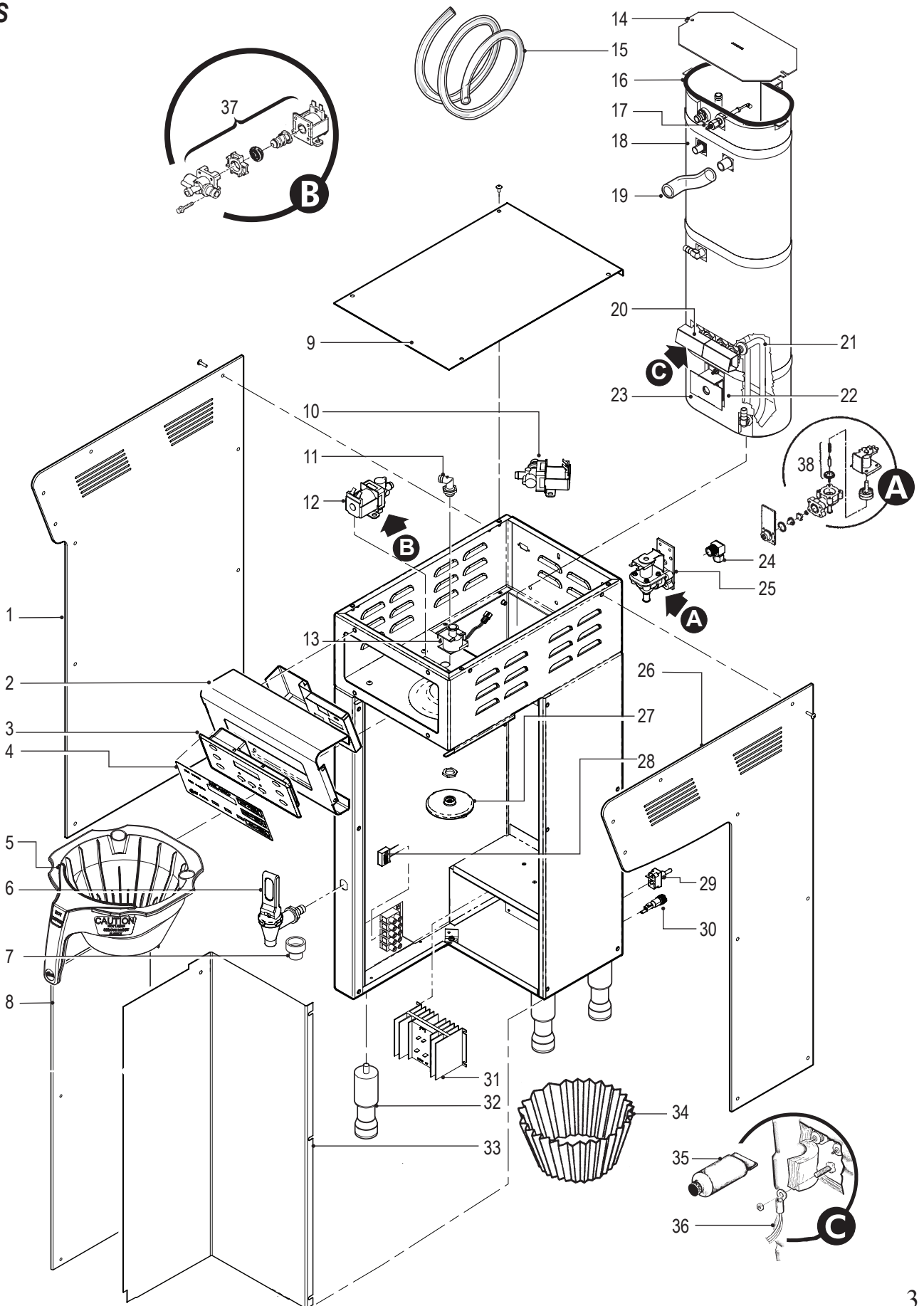

Item N ^o	Part N ^o	Description
1	WC-61565	PANEL, L-SHAPED
2	WC-61562	COVER, FRONT
3	WC-37176	KIT, UCM & LABEL INSTRUCTIONS
4	WC-39593	LABEL, UCM OVERLAY 3-BATCH SINGLE
4A	WC-39592	LABEL, UCM OVERLAY 2-BATCH SINGLE
4B	WC-39591	LABEL, UCM OVERLAY 1-BATCH SINGLE
5	WC-3417	BREWCONE ASSY, W/SPLASH POCKET BRN
6	WC-1853	FAUCET, ASSEMBLY TPC
7	WC-1805	SEAT CUP, FAUCET
8	WC-61287	PANEL, INTERSECTION RIGHT
9	WC-61561	COVER, TOP
10	WC-37122*	KIT, DUMP VALVE RIGHT 120V 14W
11	WC-2977-101	FITTING, SPRAYHEAD
12	WC- 844-101*	VALVE, BY-PASS W/RESISTOR
13	WC- 442*	SOLENOID, LOCK BREWCONE RIGHT
14	WC-5851	COVER, TANK 2/NOTCHES
15	WC-5310*	TUBE, 5/16" I.D. X 1/8" SILICONE
16	WC-43062*	GASKET, TANK LID
17	WC-5502-101*	KIT, PROBE, WATER LEVEL W/FTNG, O'RING, NUT
18	WC-62032	TANK, COMPLETE TP2S ULTEM FITTINGS

Item N ^o	Part N ^o	Description
19	WC-5350	TUBE, 1/2" ID x 1/8W SILICONE
20	WC-4394*	GUARD, SHOCK HEATING ELEMENT, 2 REQ'D
21	WC- 906-04*	ELEMENT, HEATING 2KW 220V W/JAM NT & WSHR
22	WC- 522*	THERMOSTAT, RESET
23	WC-43055*	GUARD, SHOCK RESET THERMOSTAT
24	WC-2402P*	ELBOW, 3/8"FL x 3/8" NPT PLATED
25	WC- 847*	VALVE, WATER INLET 2GPM 120V 10W
26	WC-61285	PANEL, L-SHAPE RIGHT
27	WC-29050*	SPRAYHEAD, AMBER ADVANCED FLOW
28	WC-8591*	CAPACITOR X2
29	WC- 103*	SWITCH, TOGGLE NON-LIT DPST 25A 125/250VAC
30	WC-1501	FUSE HOLDER ASSY W/5A FUSE
31	WC-8559	RELAY, SOLID STATE W/INTEGRATED HTSNK
32	WC-3528	LEG, 4" ADJUSTABLE
33	WC-61290	COVER, CENTER WRAP
34	GEM-6*	FILTER, 500PK 12 1/2" X 4"
35	WC-5231*	COMPOUND, SILICONE
36	WC-1438-101*	SENSOR, HEATING TANK
37	WC-37132	KIT, VALVE REPAIR
38	WC-3765L*	KIT, VALVE REPAIR WATER INLET

* Recommended parts to stock.

ELECTRICAL SCHEMATIC

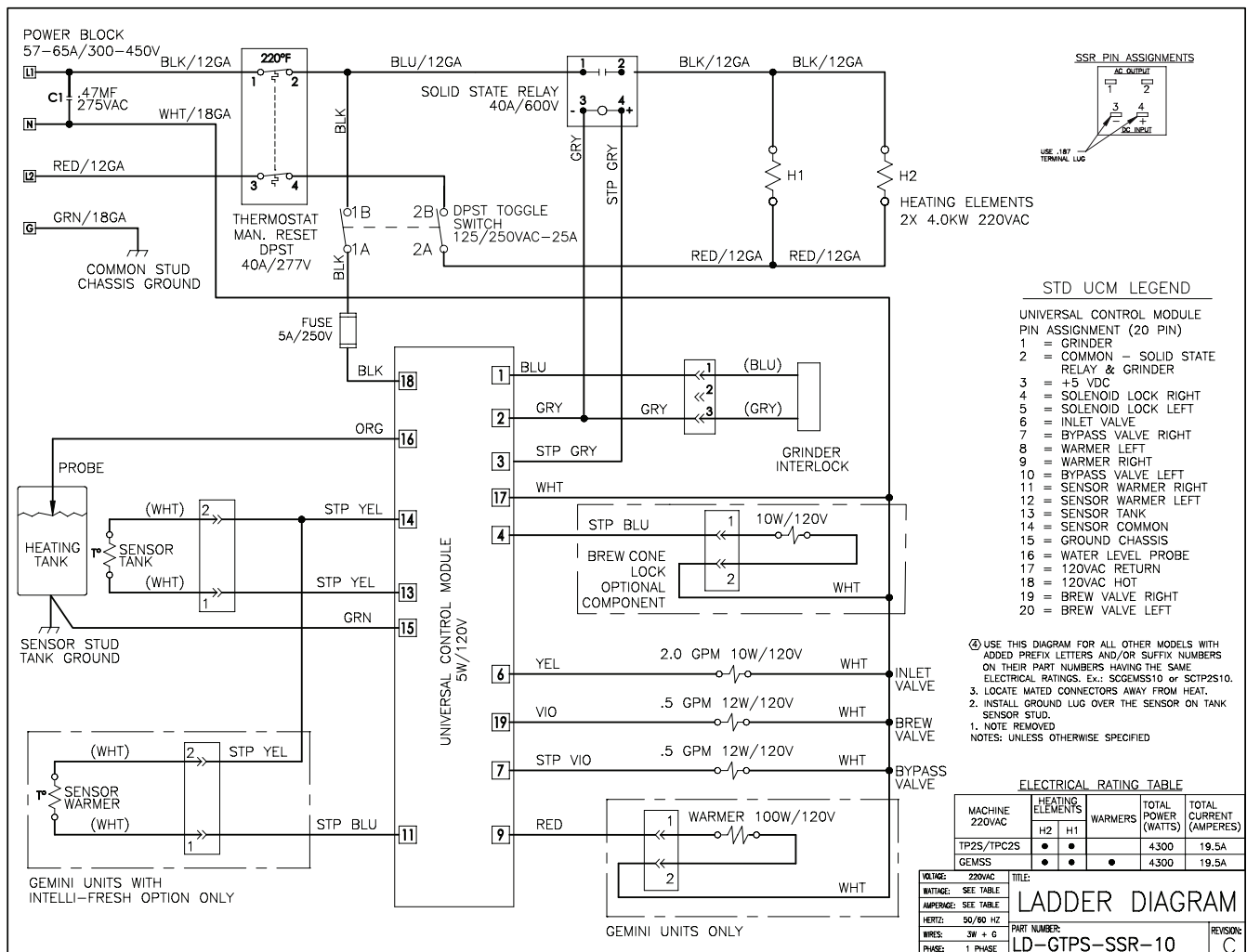

TLCG1509S Milano 1.5 Gallon Server Instructions

BREWING INTO SERVERS

Use only coffee or water in the insulated dispenser. Do not use the thermoserver to dispense any other beverage. Preheating is recommended.

1. Place a clean and empty server centered under the brewcone of the Milano brewer.
2. Make sure the screen reads **READY TO BREW**.
3. Fill brewcone with the correct measure of ground coffee for the volume of coffee you wish to brew.
4. Press the desired brew button on the side of the brewer with server you wish to brew into.
5. Allow coffee in the brewcone to drip completely before removing the insulated server.

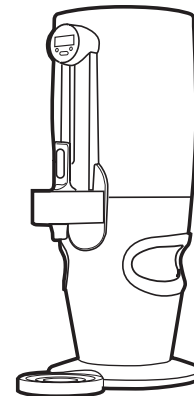

WARNING – SERVERS MAY BE HEAVY WHEN FILLED.
CARE MUST BE TAKEN WHEN TRANSPORTING TO AVOID DROPPING OR SPILLING.

SERVICING

Completely drain the unit of any coffee. Allow server to cool. Unscrew and remove the lid and tube assembly.

REPLACING THE GAUGE GLASS

The gauge glass can be removed for maintenance and cleaning.

1. Remove the gauge glass shield by pulling upward.
2. Carefully, pull up on the gauge glass to free it from the silicone base gasket that sits on the faucet assembly.
3. Pull off the silicone cap on top of the tube.
4. Scrub inside the glass with a tube cleaning brush and mild detergent solution. Inspect the glass tube for cracks or chips.



WARNING – If gauge glass was broken, carefully remove all traces of glass. Brush out the silicone base. From inside the liner, brush out the faucet shank. Run clear water through the shank to make sure any glass shards have been washed from the faucet and base.

5. Check the top cap and bottom silicone base. Clean these fittings, making sure they are not leaking. Replace if necessary.
6. Once clean and dry, replace all parts that were serviced.

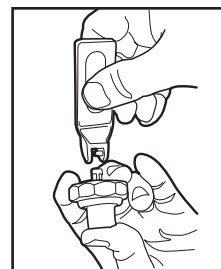

SERVICING THE FAUCET

The faucet will require periodic cleaning and maintenance.

2. Disassemble the faucet. Unscrew the bonnet from the body of the faucet.
3. Remove the faucet handle by pressing inward on the seat cup (see illustration, right) then unhooking the handle from the center shaft.
4. The seat cup, center shaft and spring will now separate from the bonnet.
5. You may now clean the parts of the faucet (illustration, bottom right). Check the seat cup for tearing or splitting. Make sure that the faucet spring is free of corrosion. Replace these items if necessary.

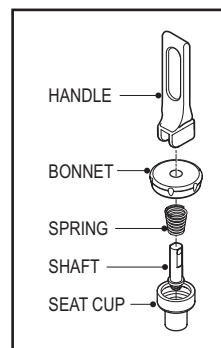

Cleaning and Sanitizing Instructions for TLCG15

These cleaning and sanitizing instructions are only a guide line to be used for the cleaning and sanitizing of the TLCG15. Your current in-house cleaning and sanitizing methods may be just as effective.

For cleaning and sanitizing of the TLCG15, the three sink method is recommended. This method consists of a sink of water filled with a detergent and water solution, a fresh water rinse, and a sink filled with an aqueous sanitizing solution. Immersion of parts in commercial BarTabs/Sani-Tabs sanitizing solution is recommended. The solution must be warm (75°F.) Let the parts soak at least one minute.



CAUTION

Do not immerse in water.
Do not place in dishwasher.
Do not use harsh powders or cleansers containing chlorine.
Do not use a wire brush or pot scour to clean inside liner.

1. Daily, Rinse the unit after use.

- a. Rinse unit with hot water.
- b. Fill unit with hot water.
- c. Open unit and empty contents completely.

2. Clean and sanitize the lid assembly.

- a. Remove lid from unit and submerge it in cleaning solution, cleaning thoroughly.
- b. Using a tube cleaning brush, clean inside the filling tube.
- c. Rinse with clean water.
- d. Submerge in sanitizing solution for 5 minutes then air dry completely.

Cleaning and Sanitizing Instructions for TLCG15 . . . Continued

3. Cleaning and sanitizing body assembly.

- Fill the unit with cleaning solution. With a sponge brush, thoroughly clean inside liner.
- Rinse the unit with a fresh water rinse.
- Fill unit with sanitizing solution. Allow to sit for 5 minutes then drain through the faucet.
- Wipe outside of unit with clean cloth moistened with cleaning solution.
- Place body assembly upside down on rack to thoroughly air dry.

4. Cleaning the faucet parts.

- Unscrew the bonnet/handle assembly from the faucet and disassembly removing spring, seat cup and shaft.
- Clean and rinse parts. Place in sanitizing solution for 5 minutes, remove and air dry.
- From inside the liner use a tube brush soaked in cleaning solution inserted through the faucet shank. Rinse by pouring water from inside the unit, allowing rinse water to flow into a sink until water runs clear.

5. When all pieces are completely dry reassemble for use.

Timer Instructions

Every Milano server comes with a brew quality timer attached at the top of the gauge glass cover. It is intended to keep track of the coffee holding time.

The brew quality timer should be started as soon as the brew cycle is completed.

Initially, you must determine the ideal holding time for the coffee you are brewing.

Enter this into the timer. Flashing bars will notify you when this time has elapsed

and the coffee is no longer considered fresh.

I. Functions of Buttons

START/STOP: When the START/STOP button is pressed, the previously set time will display. By pressing a second time, the timer will start to count up the time. If no value has been entered or if the time has been cleared, this button will not function.

HOUR: The HOUR button sets hours, starting from left. Each time you press this button, a set of four outline bars will be added, starting from left to right. This button will not operate while timer is in the timing mode.

MINUTE: The MINUTE button sets minutes. Each time you press the MINUTE button, an outline bar will be added. Each bar represents 15 minutes, starting from bottom to top. This button is locked and will not operate during the timing mode.

HOUR + MINUTE: Pressing the HOUR and MINUTE buttons simultaneously, clears the time setting and the screen is blank.



II. Time Alarm Set

- Turning on the timer at the START/STOP button, all bars will be displayed for 0.5 seconds, then go blank. Set the time by pressing the HOUR and MINUTE buttons.
- Press START/STOP button to start counting up the time. The outline bar on the left bottom will start to flash first. The other bars will keep the previous static status. When the time period is completed, the solid bars of the initial time setting will display on the screen. Solid bars indicate the time that has passed, the outline bars show the total programmed alarm time.
- The HOUR and MINUTE buttons will be locked after the time count-up mode starts.
- Pressing START/STOP button while in the count-up mode will return you to the previous setting.

III. Alarm Signal

- Alarm range: 15 minutes to 3 hours.
- All 3 columns of solid bars will flash for 30 minutes once the preprogrammed time is reached. During the alarming count-up time, press START/STOP button to stop and return to the previous setting.

IV. Power Save

After 30 minutes of inactivity under time set up mode, the power save state will activate. The LCD screen will be off. Return to the previous setting by pressing any control button. After 30 minutes alarming, the timer will enter the time set up mode.

IV. LCD Display

Icon Style: Total 3 columns of 4 bars each. Each column represents an hour, and each bar represents 15 minutes.

The bars are in 4 formats:

- A static outlined bar represents a 15 minute preset time increment.
- A flashing outlined bar represents the countdown of a 15 minute increment.
- A static solid bar represents a 15 minute increment that has already passed.
- All 3 columns of solid bars flashing is the alarm signaling.

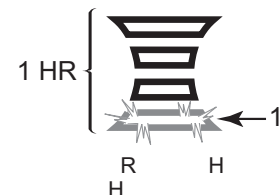

Timer Setting Example

How to set the freshness timer for 1½ hours.

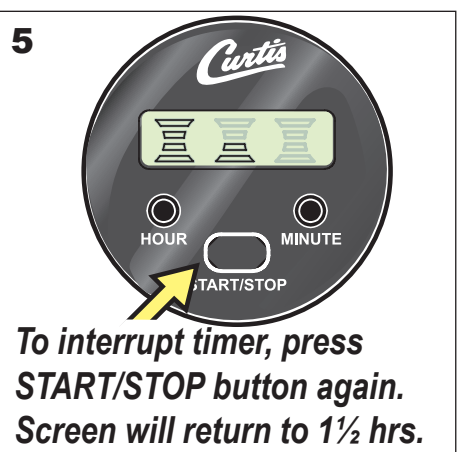
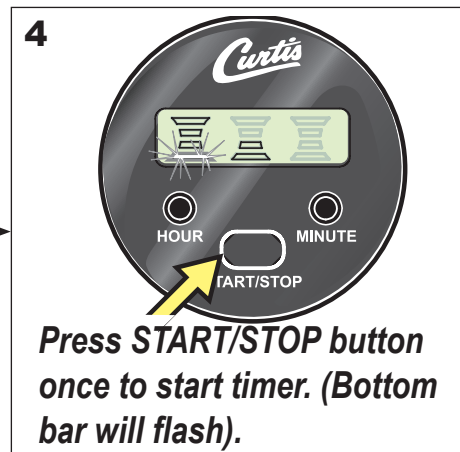
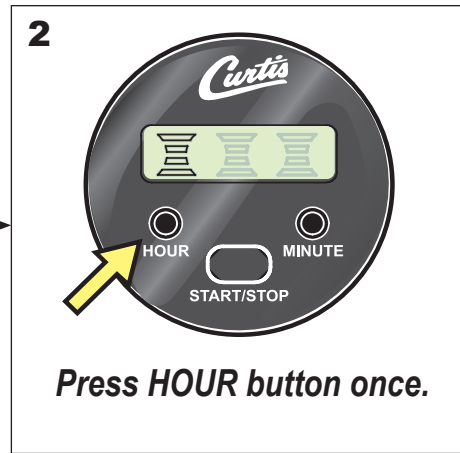
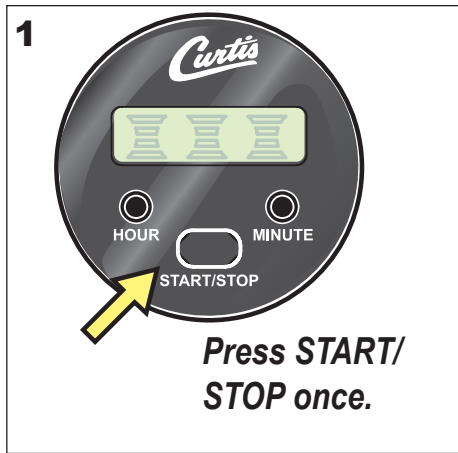

Product Warranty Information

The Wilbur Curtis Company certifies that its products are free from defects in material and workmanship under normal use. The following limited warranties and conditions apply:

- 3 Years, Parts and Labor, from Original Date of Purchase on digital control boards.
- 2 Years, Parts, from Original Date of Purchase on all other electrical components, fittings and tubing.
- 1 Year, Labor, from Original Date of Purchase on all electrical components, fittings and tubing.

Additionally, the Wilbur Curtis Company warrants its Grinding Burrs for Forty (40) months from date of purchase or 40,000 pounds of coffee, whichever comes first. Stainless Steel components are warranted for two (2) years from date of purchase against leaking or pitting and replacement parts are warranted for ninety (90) days from date of purchase or for the remainder of the limited warranty period of the equipment in which the component is installed.

All in-warranty service calls must have prior authorization. For Authorization, call the Technical Support Department at 1-800-995-0417. Effective date of this policy is April 1, 2003.

Additional conditions may apply. Go to www.wilburcurtis.com to view the full product warranty information.

CONDITIONS & EXCEPTIONS

The warranty covers original equipment at time of purchase only. The Wilbur Curtis Company, Inc., assumes no responsibility for substitute replacement parts installed on Curtis equipment that have not been purchased from the Wilbur Curtis Company, Inc. The Wilbur Curtis Company will not accept any responsibility if the following conditions are not met. The warranty does not cover and is void under the following circumstances:

- 1) **Improper operation of equipment:** *The equipment must be used for its designed and intended purpose and function.*
- 2) **Improper installation of equipment:** *This equipment must be installed by a professional technician and must comply with all local electrical, mechanical and plumbing codes.*
- 3) **Improper voltage:** *Equipment must be installed at the voltage stated on the serial plate supplied with this equipment.*
- 4) **Improper water supply:** *This includes, but is not limited to, excessive or low water pressure, and inadequate or fluctuating water flow rate.*
- 5) **Adjustments and cleaning:** *The resetting of safety thermostats and circuit breakers, programming and temperature adjustments are the responsibility of the equipment owner. The owner is responsible for proper cleaning and regular maintenance of this equipment.*
- 6) **Damaged in transit:** *Equipment damaged in transit is the responsibility of the freight company and a claim should be made with the carrier.*
- 7) **Abuse or neglect (including failure to periodically clean or remove lime accumulations):** *Manufacturer is not responsible for variation in equipment operation due to excessive lime or local water conditions. The equipment must be maintained according to the manufacturer's recommendations.*
- 8) **Replacement of items subject to normal use and wear:** *This shall include, but is not limited to, light bulbs, shear disks, "O" rings, gaskets, silicone tube, canister assemblies, whipper chambers and plates, mixing bowls, agitation assemblies and whipper propellers.*
- 9) **Repairs and/or Replacements** *are subject to our decision that the workmanship or parts were faulty and the defects showed up under normal use. All labor shall be performed during regular working hours. Overtime charges are the responsibility of the owner. Charges incurred by delays, waiting time, or operating restrictions that hinder the service technician's ability to perform service is the responsibility of the owner of the equipment. This includes institutional and correctional facilities. The Wilbur Curtis Company will allow up to 100 miles, round trip, per in-warranty service call.*

RETURN MERCHANDISE AUTHORIZATION: *All claims under this warranty must be submitted to the Wilbur Curtis Company Technical Support Department prior to performing any repair work or return of this equipment to the factory. All returned equipment must be repackaged properly in the original carton. No units will be accepted if they are damaged in transit due to improper packaging. **NO UNITS OR PARTS WILL BE ACCEPTED WITHOUT A RETURN MERCHANDISE AUTHORIZATION (RMA). RMA NUMBER MUST BE MARKED ON THE CARTON OR SHIPPING LABEL.** All in-warranty service calls must be performed by an authorized service agent. Call the Wilbur Curtis Technical Support Department to find an agent near you.*

ECN 14810 . 3/6/13@13.9 revB



WILBUR CURTIS CO., INC.

6913 Acco St., Montebello, CA 90640-5403 USA

Phone: 800/421-6150 ♦ Fax: 323-837-2410

♦ Technical Support Phone: 800/995-0417 (M-F 5:30A - 4:00P PST) ♦ E-Mail: techsupport@wilburcurtis.com

♦ Web Site: www.wilburcurtis.com

Printed in U.S.A. 3/2013 F-3536 Rev B