

HEAT-WAVE MERCHANTISERS

EURO STYLE
HWE24, HWE30, & HWE36, HWE48

CLASSIC STYLE
HWC24, HWC30, HWC36 & HWC48

Installation and Operation Instructions

2M-Z14539 Rev. - 8/11/2011

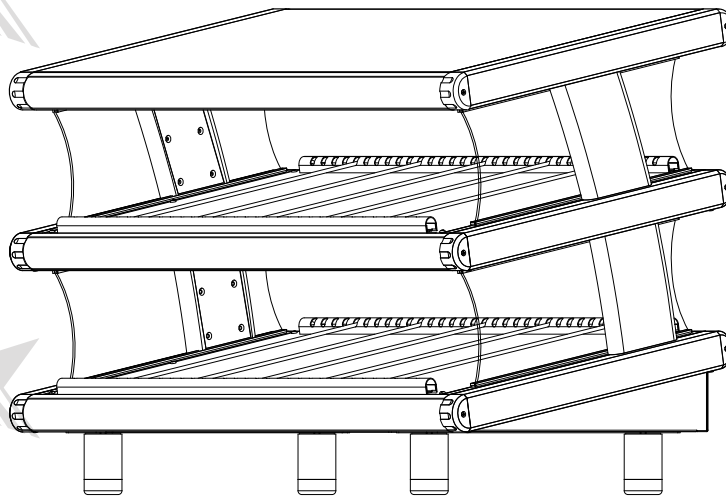

HWE36S2



SAFETY SYMBOL



These symbols are intended to alert the user to the presence of important operating and maintenance instructions in the manual accompanying the appliance.

RETAIN THIS MANUAL FOR FUTURE REFERENCE NOTICE

Using any part other than genuine Star factory supplied parts relieves the manufacturer of all liability.

Star reserves the right to change specifications and product design without notice. Such revisions do not entitle the buyer to corresponding changes, improvements, additions or replacements for previously purchased equipment.

Due to periodic changes in designs, methods, procedures, policies and regulations, the specifications contained in this sheet are subject to change without notice. While Star International Holdings Inc., Company exercises good faith efforts to provide information that is accurate, we are not responsible for errors or omissions in information provided or conclusions reached as a result of using the specifications. By using the information provided, the user assumes all risks in connection with such use.

MAINTENANCE AND REPAIRS

Contact your local authorized service agent for service or required maintenance.

Please record the model number, serial number, voltage and purchase date in the area below and have it ready when you call to ensure a faster service.

Model No. _____
Serial No. _____
Voltage _____
Purchase Date _____

Authorized Service Agent Listing

Reference the listing provided with the unit

or

for an updated listing go to:

Website: www.star-mfg.com
E-mail Service@star-mfg.com

Service Help Desk

Business Hours: 8:00 am to 4:30 p.m. Central Standard Time

Telephone: (314) 678-6303

Fax: (314) 781-2714

E-mail Parts@star-mfg.com
Service@star-mfg.com
Warranty@star-mfg.com

Website: www.star-mfg.com

Mailing Address: Star International Holdings Inc., Company
10 Sunnen Drive
St. Louis, MO 63143
U.S.A

TABLE OF CONTENTS

Specifications	
Euro Specifications	4
Classic Specifications	5
Plug Configuration	5
Features & Benefits	6
General Information	
Inspection	7
Uncrating & Inspecting.	7
Assembly	7
Locating the Unit.	7
Installation	8
Electrical Connection	8
Operation	
Initial Start-Up	8
Operation	8
Cleaning	9
Maintenance	9
Warranty	10
Wiring Diagram	11 - 15
Exploded View & Parts List	16 - 20

NOTICE Service on this or any other Star appliance must be performed by qualified personnel only. Consult your Star Authorized Service Agent Directory. You can call us at 314-678-6303 or visit our website WWW.STAR-MFG.COM for the service agent nearest you.

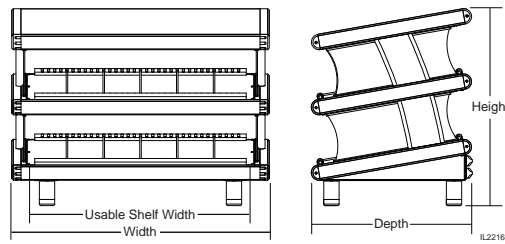

EURO SPECIFICATIONS

Model No	Width	Width Heated Shelf	Depth	Height	Divider Bars per Shelf	Light Bulbs per Shelf	Voltage	Watts	Plug Type	Appro. Weight		
										Shipping	Installed	
Single Shelf Slanted												
HWE24S1	30.0" (76.2cm)	25.7" (65.2cm)	26.1" (66.4cm)	18.4" (46.7cm)	5	2	120V	820	NEMA 5-15P			
HWE30S1	36.0" (91.4cm)	31.7" (80.5cm)			6		230V	810	CEE7/VII			
HWE36S1	42.0" (106.7cm)	37.7" (95.7cm)			7		120V	960	NEMA 5-15P			
							230V	950	CEE7/VII			
HWE48S1	54.0" (137.2cm)	49.7" (126.2cm)			8	4	120V	1,170	NEMA 5-15P			
230V							1,160	CEE7/VII				
HWE48S1C							120C	1,640	NEMA 5-20P			
Double Shelf Slanted												
HWE24S2	30.0" (76.2cm)	25.7" (65.2cm)	26.1" (66.4cm)	32.1" (81.4cm)	5	2	120V	1,640	NEMA 5-15P			
HWE24S2C							230V	1,620	CEE7/VII			
HWE30S2	36.0" (91.4cm)	31.7" (80.5cm)					6	120C	1,640	NEMA 5-20P		
								120V	1,920	NEMA 5-20P		
HWE36S2	42.0" (106.7cm)	37.7" (95.7cm)			7	230V	1,900	CEE7/VII				
						208/240V	1,920	NEMA 5-20P				
HWE48S2	54.0" (137.2cm)	49.7" (126.2cm)			8	4	120V	2,340	NEMA L 14-20P			
							230V	2,320	CEE7/VII			
			208/240V	2,340			NEMA L 14-20P					
Single Shelf Horizontal												
HWE24H1	30.0" (76.2cm)	25.7" (65.2cm)	26.5" (67.3cm)	14.1" (35.8cm)	5	2	120V	820	NEMA 5-15P			
HWE30H1							230V	810	CEE7/VII			
HWE36H1	36.0" (91.4cm)	31.7" (80.5cm)					6	120V	960	NEMA 5-15P		
								230V	950	CEE7/VII		
HWE48H1	42.0" (106.7cm)	37.7" (95.7cm)			7	120V	1,170	NEMA 5-15P				
						230V	1,160	CEE7/VII				
HWE48H1C	120C	1,640			NEMA 5-20P							
Double Shelf Horizontal												
HWE24H2	30.0" (76.2cm)	25.7" (65.2cm)	26.5" (67.3cm)	27.6" (70.1cm)	5	2	120V	1,640	NEMA 5-15P			
HWE24S2C							230V	1,620	CEE7/VII			
HWE30S2	36.0" (91.4cm)	31.7" (80.5cm)					6	120C	1,640	NEMA 5-20P		
								120V	1,920	NEMA 5-20P		
HWE36S2	42.0" (106.7cm)	37.7" (95.7cm)			7	230V	1,900	CEE7/VII				
						208/240V	1,920	NEMA 5-20P				
HWE48S2	54.0" (137.2cm)	49.7" (126.2cm)			8	4	120V	2,340	NEMA L 14-20P			
							230V	2,320	CEE7/VII			
			208/240V	2,340			NEMA L 14-20P					

CLASSIC SPECIFICATIONS											
Model No	Width	Width Heated Shelf	Depth	Height	No of Divider Bars per Shelf	No of Light Bulbs per Shelf	Voltage	Watts	Plug Type	Appro. Weight	
										Shipping	Installed
SINGLE SHELF											
HWC24S1	24.0" (60.9cm)	23.0" (58.4cm)	24.0" (61.0cm)	17.8" (45.2cm)	5	2	120V	640	NEMA 5-15P	-	-
HWC30S1	30.0" (76.2cm)	29.0" (73.7cm)			6			770		-	-
HWC36S1	36.0" (91.4cm)	35.0" (88.9cm)			7			895		-	-
HWC48S1	48.0" (121.9cm)	47.0" (119.4cm)			8	4		1,270		-	-
DOUBLE SHELF											
HWC24S2	24.0" (60.9cm)	23.0" (58.4cm)	24.0" (61.0cm)	32.3" (82.0cm)	5	2	120V	1,280	NEMA 5-15P	-	-
HWC30S2	30.0" (76.2cm)	29.0" (73.7cm)			6			1,540	NEMA 5-15P	-	-
HWC30S2C								NEMA 5-20P	-	-	
HWC36S2	36.0" (91.4cm)	35.0" (88.9cm)			7			1,790	NEMA 5-15P	-	-
HWS36S2C						NEMA 5-20P	-	-			
HWC48S2	48.0" (121.9cm)	47.0" (119.4cm)			8	4	120V 208/240V	2,540	NEMA L14-20P	-	-

PLUG CONFIGURATIONS

All units are supplied from the factory with an electrical power cord and plug attached. These cord assemblies are properly grounded, DO NOT cut or remove the grounding lug.

DO NOT use the unit if the cord assembly shows any signs of damage.



WARNING

For safe and proper operation, plug unit into a properly grounded electrical outlet, with the correct voltage & configuration. If the plug and receptical do not match up, contact a qualified electrician.

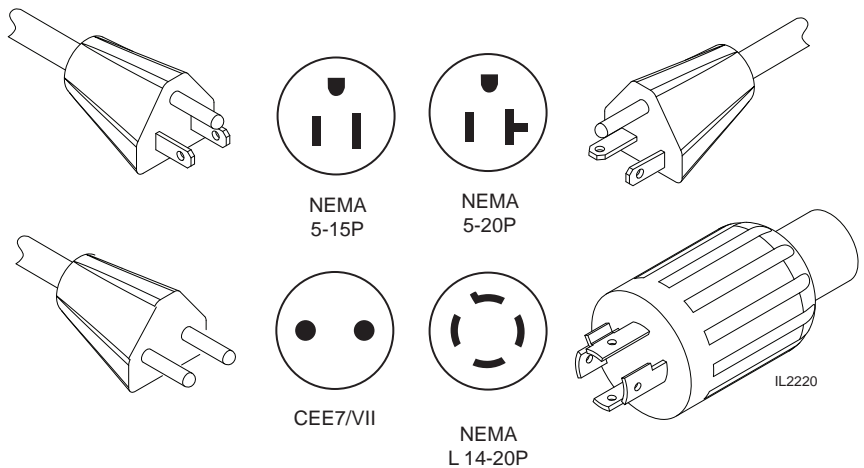

FEATURES AND BENIFITS

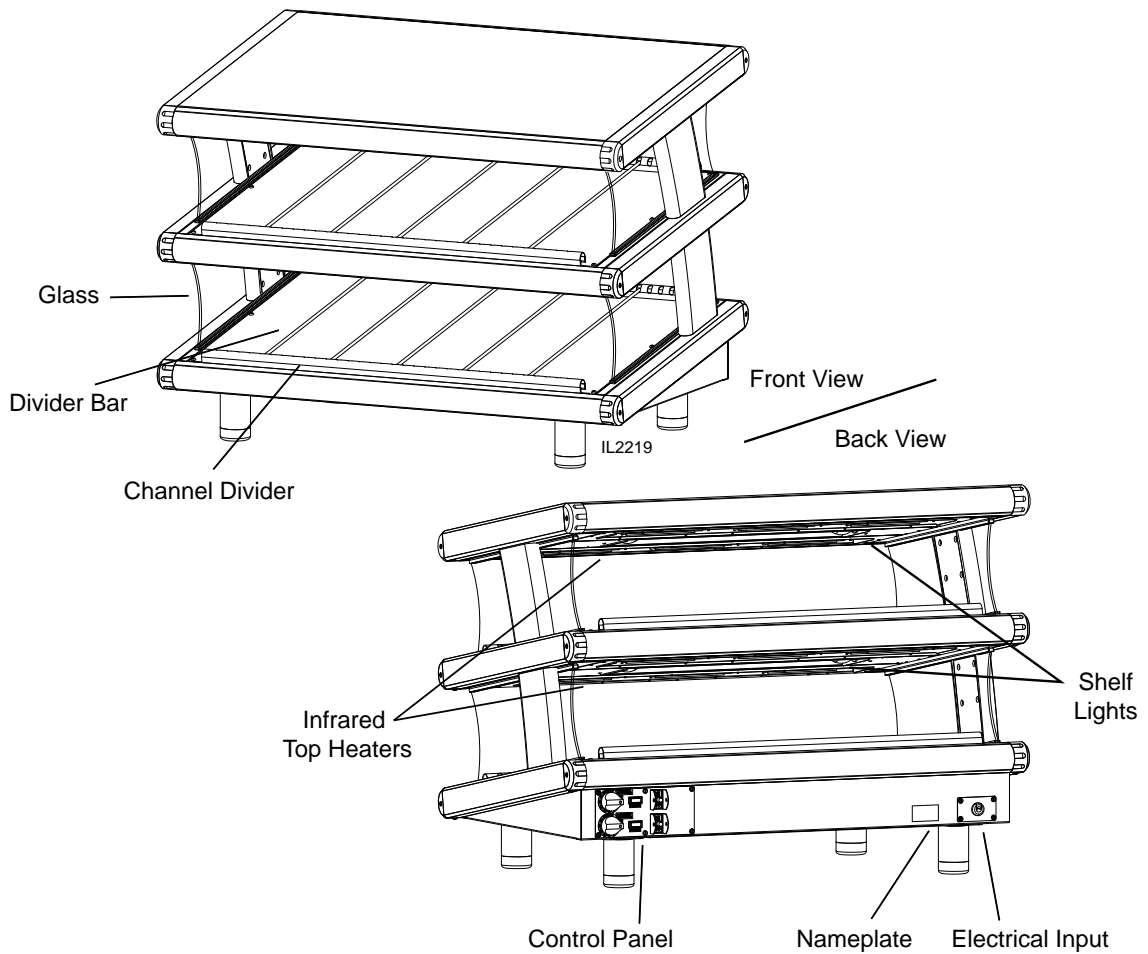

GENERAL INFORMATION

This equipment is designed and sold for commercial use only by personnel trained and experienced in its operation and is not sold for consumer use in and around the home nor for use directly by the general public in food service locations.

Before using your new equipment, read and understand all the instructions & labels associated with the unit prior to putting it into operation. Make sure all people associated with its use understand the units operation & safety before they use the unit.

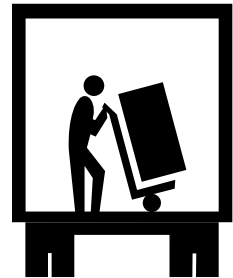

INSPECTION

UN-CRATING AND INSPECTING

This unit comes bolted to a skid from the factory (see illustration), the bolts must be removed & legs installed before putting it in use. The glass and legs are packed separately.

Unpack the unit and components from the shipping container. Remove all packing material. If damage is discovered, file a claim immediately with the carrier that handled the shipment. Do not operate the unit if it was damaged during shipping. All shipping containers should be checked for freight damage both visible and concealed. This unit has been tested and carefully packaged to insure delivery of your unit in perfect condition. If equipment is received in damaged condition, either apparent or concealed, a claim must be made with the delivering carrier.

Concealed damage or loss - if damage or loss is not apparent until after equipment is unpacked, a request for inspection of concealed damage must be made with carrier within 15 days. Be certain to retain all contents plus external and internal packaging materials for inspection. The carrier will make an inspection and will supply necessary claim forms.

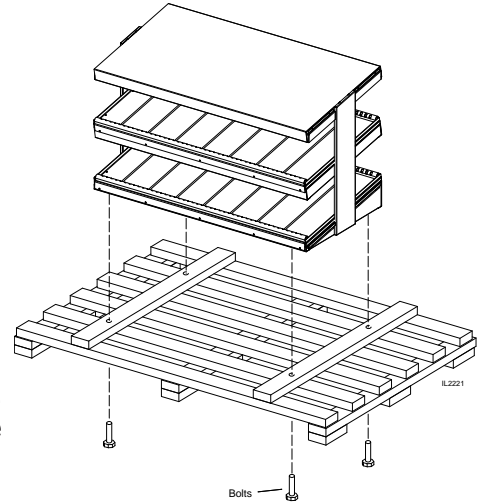

ASSEMBLY

The unit was shipped fully assembled and ready to plug into a standard outlet specified for its voltage and amp draw, with the exception of the legs and glass. If improper electrical supply is determined, contact a qualified electrician prior to using the unit. Removal and replacement of the power cord and plug will void the warranty. For assistance, contact your local authorized service agent for service or required maintenance.

Before using the unit for the first time, wipe down the exterior with a damp cloth.

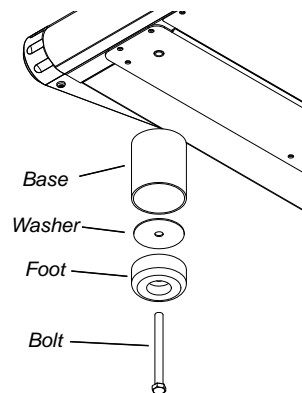

*Foot Installation
Euro Models*

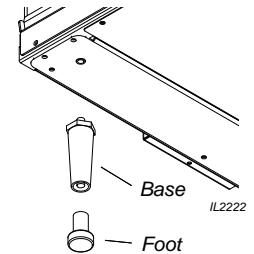

*Foot Installation
Classic Models*

LOCATING THE UNIT

To achieve best performance locate the unit in an area where the surrounding air temperature is constant and is a minimum of 70°F (21°C). Areas which are susceptible to active air movements such as open doors, cooling fans etc., should be avoided.

INSTALLATION

These models are equipped for the voltage and wattage indicated on the nameplate. The nameplate is located on the back of the unit. These units are designed to operate on alternating current (A.C.), two wire single phase service only and are equipped with an approved lead in cord set with a three prong grounding type plug.

ELECTRICAL CONNECTION

Once the unit is in position, verify the electrical supply matches the units requirements, located on the rear of the toaster.



DO NOT CONNECT TO ANY OTHER TYPE OF VOLTAGE OR THE MACHINE WILL BE SERIOUSLY DAMAGED.

WARNING DO NOT USE FOREIGN OBJECTS TO REMOVE THE TOAST. DOING SO MAY CAUSE DAMAGE TO THE ELEMENTS OR POSSIBLE LOSS OF LIFE.

OPERATIONS

INITIAL START-UP

Before using the unit for the first time, wipe down the surface a damp cloth using warm water and mild detergent.

OPERATION

The heating elements & lights are controlled by the switch located on the back of the unit. When the switch is turned "ON" the indicator light will turn on and the unit will begin to heat and the shelf light will turn on. Set the thermostat to the desired setting.



CAUTION

CERTAIN SURFACES ARE HOT DURING OPERATION AND CARE SHOULD BE TAKEN WHILE USING THIS UNIT.

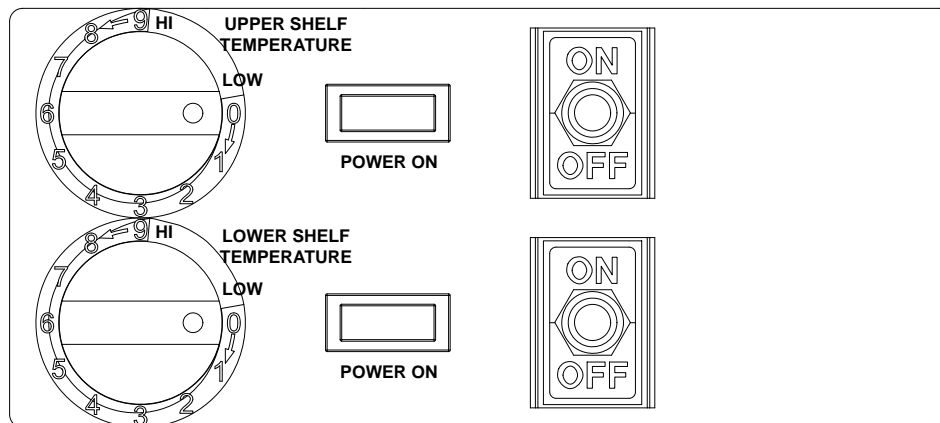

Above: Typical control panel of a two shelf merchandiser.

CLEANING

To keep your merchandiser looking new and operating properly follow the following steps on a daily basis.

1. Turn the power off.
2. Remove the product dividers and wash with warm water and mild detergent.
3. Wipe the interior & exterior metal surfaces of unit using a soft damp cloth, warm water and mild detergent.
4. Glass surfaces can be cleaned using a common glass cleaner.
5. Stubborn stains can be removed using a non-abrasive cleaner.



CAUTION

Do not immerse unit in water or hose down with water to clean. Use a damp soft cloth with a very mild soap to wipe down outside of toaster.

MAINTENANCE

LIGHTBULB REPLACEMENT

To replace the bulb, remove the element guard by removing screws, set the screws and guard aside. With unit cool, remove the bad bulb and replace with a NSF standard bulb made for food holding and display area, for replacement bulb contact a qualified Star service agent or call Star parts department at 314-678-6303.



CAUTION

NOTICE Service on this or any other Star appliance must be performed by qualified personnel only. Consult your Authorized Service Agent Directory, call us at 314-678-6303 or visit our website WWW.STAR-MFG.COM for the service agent nearest you.

THOROUGHLY INSPECT YOUR UNIT ON ARRIVAL

This unit has been tested for proper operation before leaving our plant to insure delivery of your unit in perfect condition. However, there are instances in which the unit may be damaged in transit. In the event you discover any type of damage to your product upon receipt, you must immediately contact the transportation company who delivered the item to you and initiate your claim with same. If this procedure is not followed, it may affect the warranty status of the unit.

LIMITED EQUIPMENT WARRANTY

All workmanship and material in Star products have a one (1) year limited warranty on parts & labor in the United States and Canada. Such warranty is limited to the original purchaser only and shall be effective from the date the equipment is placed in service. Star's obligation under this warranty is limited to the repair of defects without charge, by the factory authorized service agency or one of its sub-agencies. Models that are considered portable (*see below*) should be taken to the closest Star service agency, transportation prepaid.

- > Star will not assume any responsibility for loss of revenue.
- > On all shipments outside the United States and Canada, see International Warranty.
- * The warranty period for the JetStar six (6) ounce & Super JetStar eight (8) ounce series popcorn machines is two (2) years.
- * The warranty period for the Chrome-Max Griddles is five (5) years on the griddle surface. See detailed warranty provided with unit.
- * The warranty period for Teflon/Dura-Tec coatings is one year under normal use and reasonable care. This warranty does not apply if damage occurs to Teflon/Dura-Tec coatings from improper cleaning, maintenance, use of metallic utensils, or abrasive cleaners, abrasive pads, product identifiers and point-of-sale attachments, or any other non-food object that comes in continuous contact with the roller coating. This warranty does not apply to the "non-stick" properties of such materials.
- > This warranty does not apply to "Special Products" but to regular catalog items only. Star's warranty on "Special Products" is six (6) months on parts and ninety (90) days on labor.
- > This warranty does not apply to any item that is disassembled or tampered with for any purpose other than repair by a Star Authorized Service Center or the Service Center's sub-agency.
- > This warranty does not apply if damage occurs from improper installation, misuse, wrong voltage, wrong gas or operated contrary to the Installation and Operating instructions.
- > This warranty is not valid on Conveyor Ovens *unless* a "start-up/check-out" has been performed by a Factory Authorized Technician.

PARTS WARRANTY

Parts that are sold to repair out of warranty equipment are warranted for ninety (90) days. The part only is warranted. Labor to replace the part is chargeable to the customer.

SERVICES NOT COVERED BY WARRANTY

1. Travel time and mileage rendered beyond the 50 mile radius limit
2. Mileage and travel time on portable equipment (*see below*)
3. Labor to replace such items that can be replaced easily during a daily cleaning routine, ie; removable kettles on fryers, knobs, grease drawers on griddles, etc.
4. Installation of equipment
5. Damages due to improper installation
6. Damages from abuse or misuse
7. Operated contrary to the Operating and Installation Instructions
8. Cleaning of equipment
9. Seasoning of griddle plates
10. Voltage conversions
11. Gas conversions
12. Pilot light adjustment
13. Miscellaneous adjustments
14. Thermostat calibration and by-pass adjustment
15. Resetting of circuit breakers or safety controls or reset buttons
16. Replacement of bulbs
17. Replacement of fuses
18. Repair of damage created during transit, delivery, & installation OR created by acts of God

PORTABLE EQUIPMENT

Star will not honor service bills that include travel time and mileage charges for servicing any products considered "Portable" including items listed below. These products should be taken to the Service Agency for repair:

- * The Model 510FD Fryer.
- * The Model 526TOA Toaster Oven.
- * The Model J4R, 4 oz. Popcorn Machine.
- * The Model 518CMA & 526CMA Cheese Melter.
- * The Model 12MC & 15MC & 18MCP Hot Food Merchandisers.
- * The Model 12NCPW & 15NCPW Nacho Chip/Popcorn Warmer.
- * All Hot Dog Equipment **except Roller Grills & Drawer Bun Warmers.**
- * All Nacho Cheese Warmers **except Model 11WLA Series Nacho Cheese Warmer.**
- * All Condiment Dispensers **except the Model HPD & SPD Series Dispenser.**
- * All Specialty Food Warmers **except Model 130R, 11RW Series, and 11WSA Series.**
- * All QCS/RCS Series Toasters **except Model QCS3 & RCS3 Series.**
- * All Fast Steamer Models **except Direct Connect Series.**

ALL:

- * Pop-Up Toasters
- * Butter Dispensers
- * Pretzel Merchandisers
(Model 16PD-A Only)
- * Pastry Display Cabinets
- * Nacho Chip Merchandisers
- * Accessories of any kind
- * Sneeze Guards
- * Pizza Ovens
(Model PO12 Only)
- * Heat Lamps
- * Pumps-Manual

The foregoing warranty is in lieu of any and all other warranties expressed or implied and constitutes the entire warranty.

FOR ASSISTANCE

Should you need any assistance regarding the Operation or Maintenance of any Star equipment; write, phone, fax or email our Service Department. In all correspondence mention the Model number and the Serial number of your unit, and the voltage or type of gas you are using.

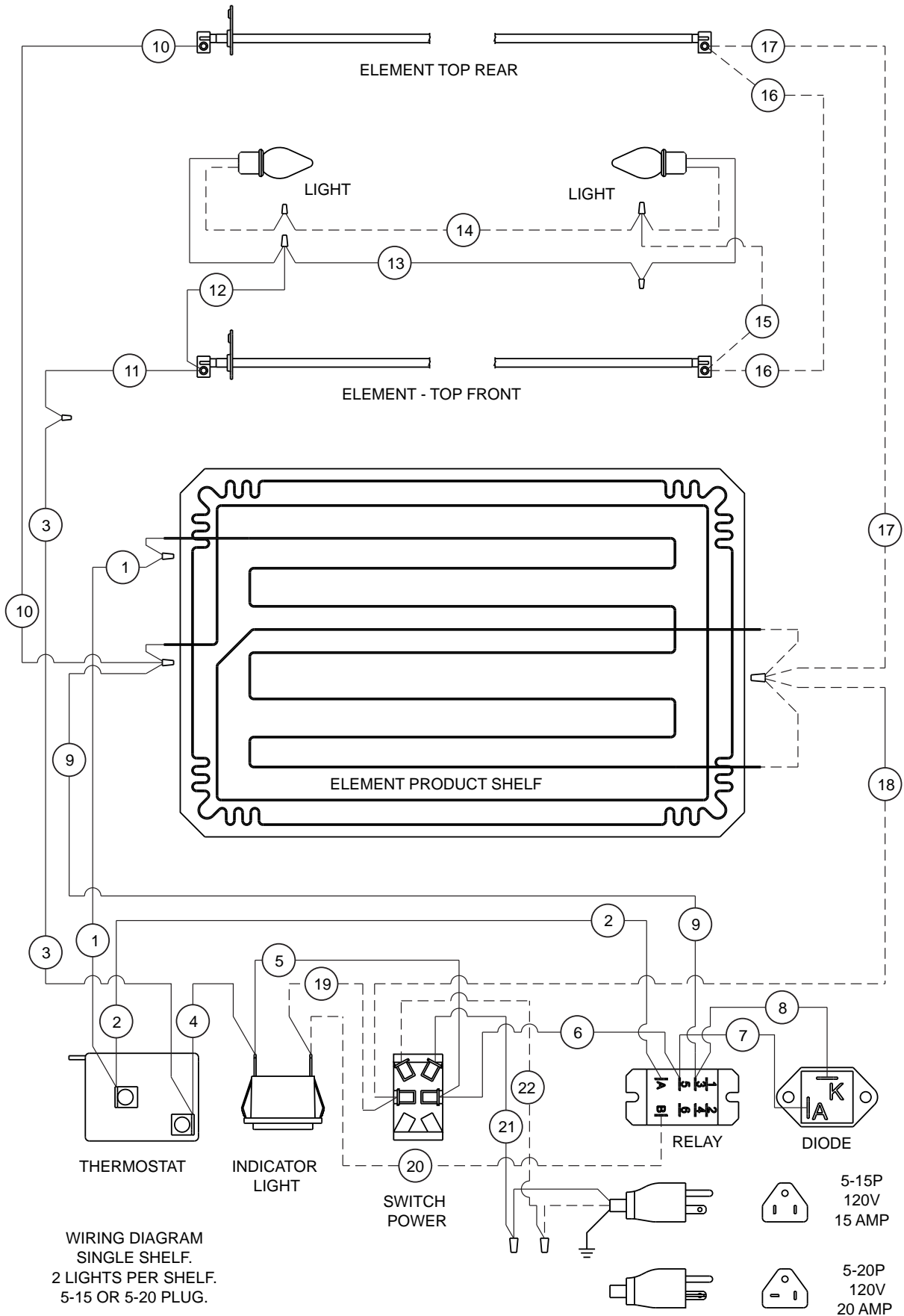

STAR MANUFACTURING INTERNATIONAL, INC.

SK2505-1 REV. -

UPPER SHELF

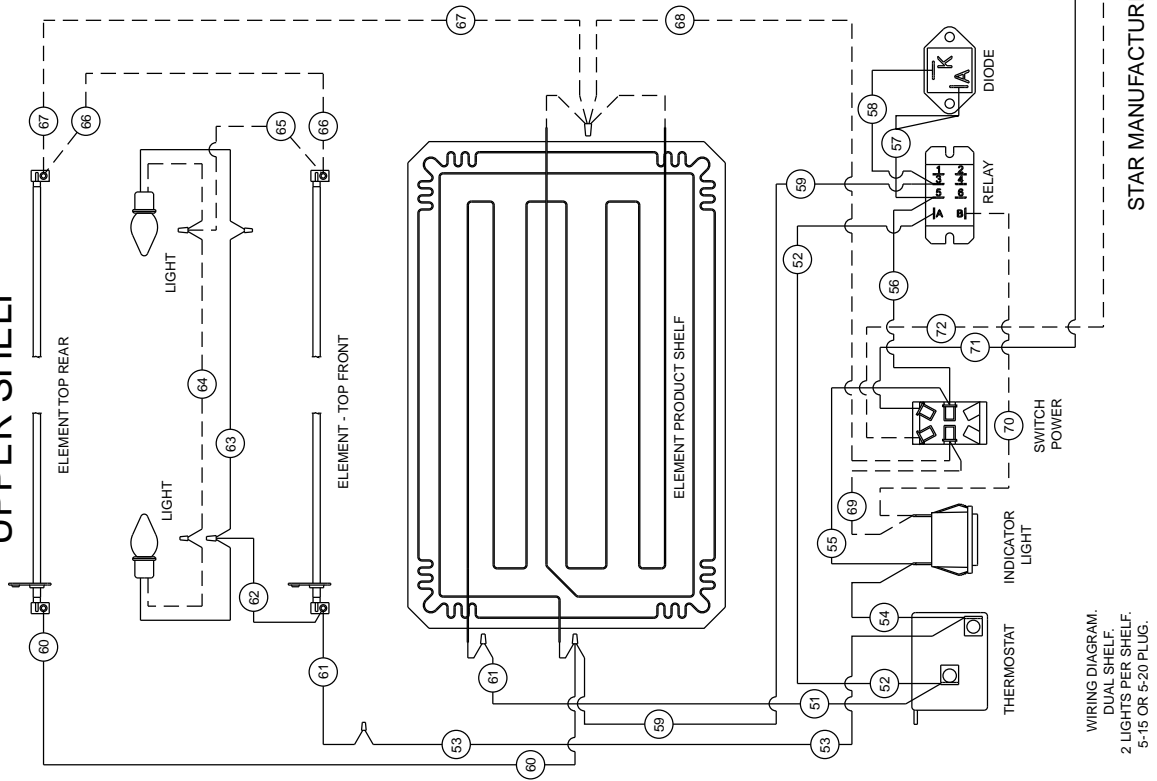

LOWER SHELF

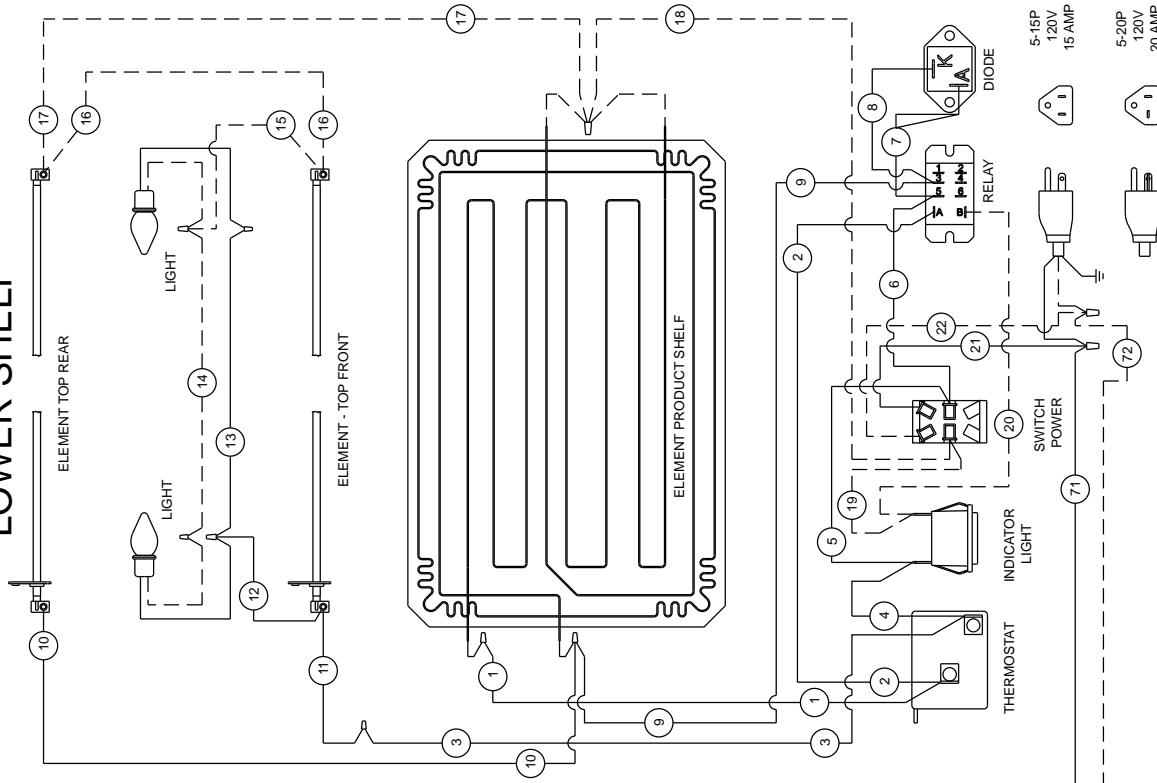

WIRING DIAGRAM.
 DUAL SHELF.
 2 LIGHTS PER SHELF.
 5-15 OR 5-20 PLUG.

STAR MANUFACTURING INTERNATIONAL, INC.

SK2505-2 REV. -

UPPER SHELF

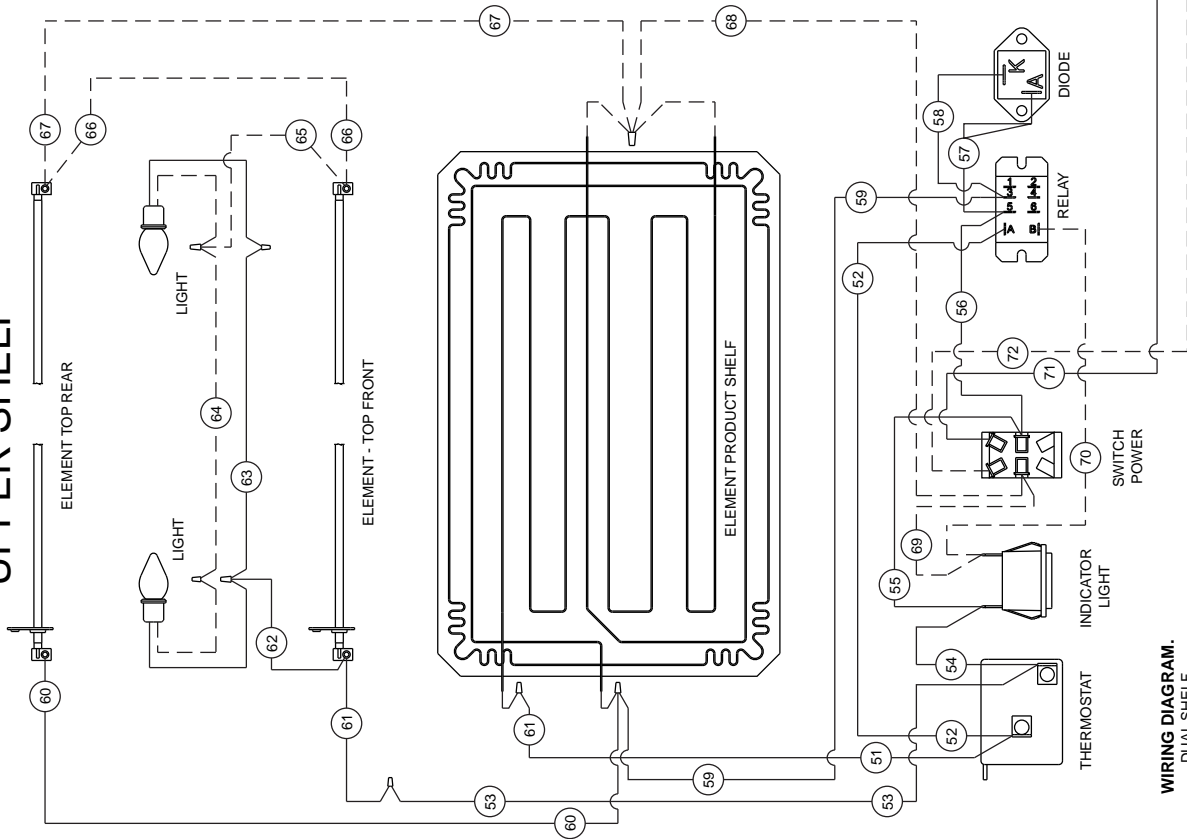

LOWER SHELF

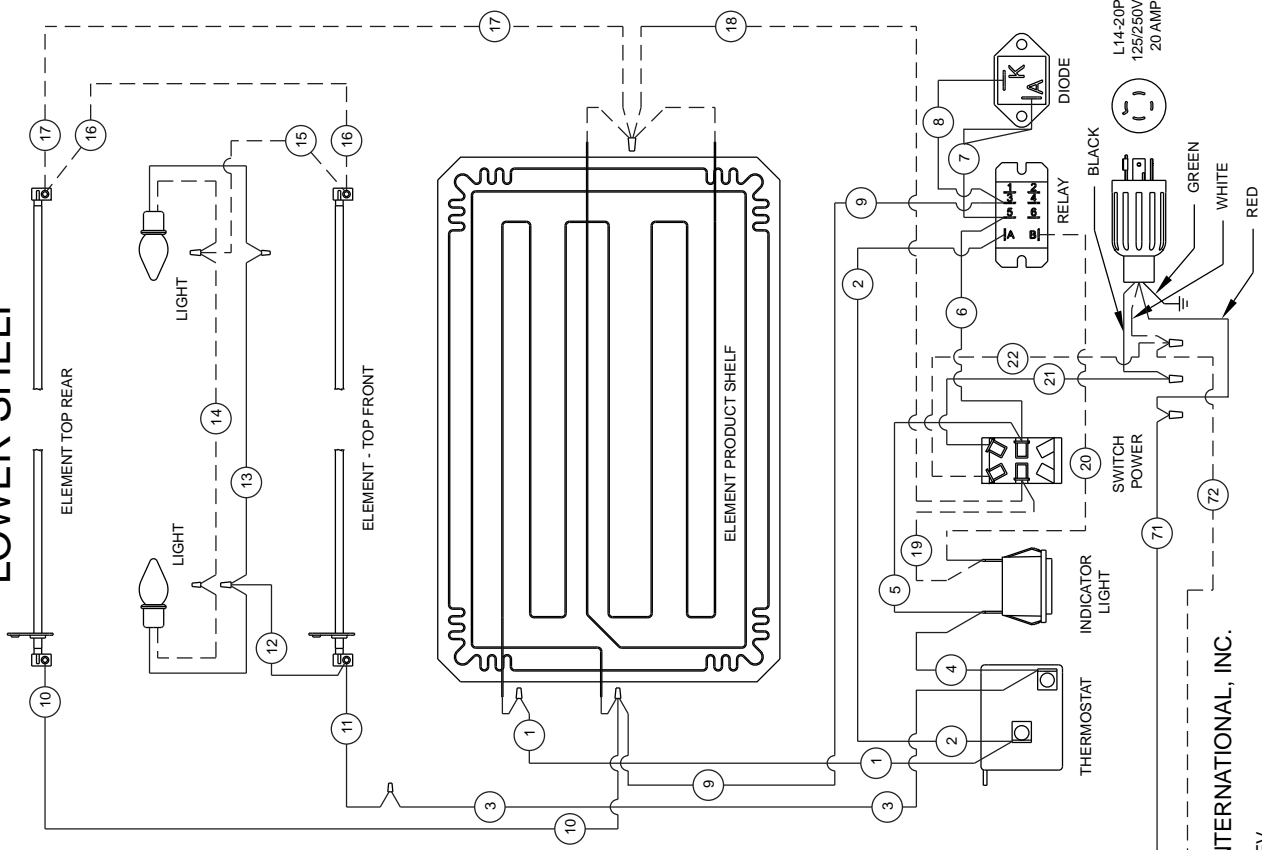

WIRING DIAGRAM.
 DUAL SHELF.
 2 LIGHTS PER SHELF.
 L14-20 PLUG.

STAR MANUFACTURING INTERNATIONAL, INC.

SK2505-3 REV. -

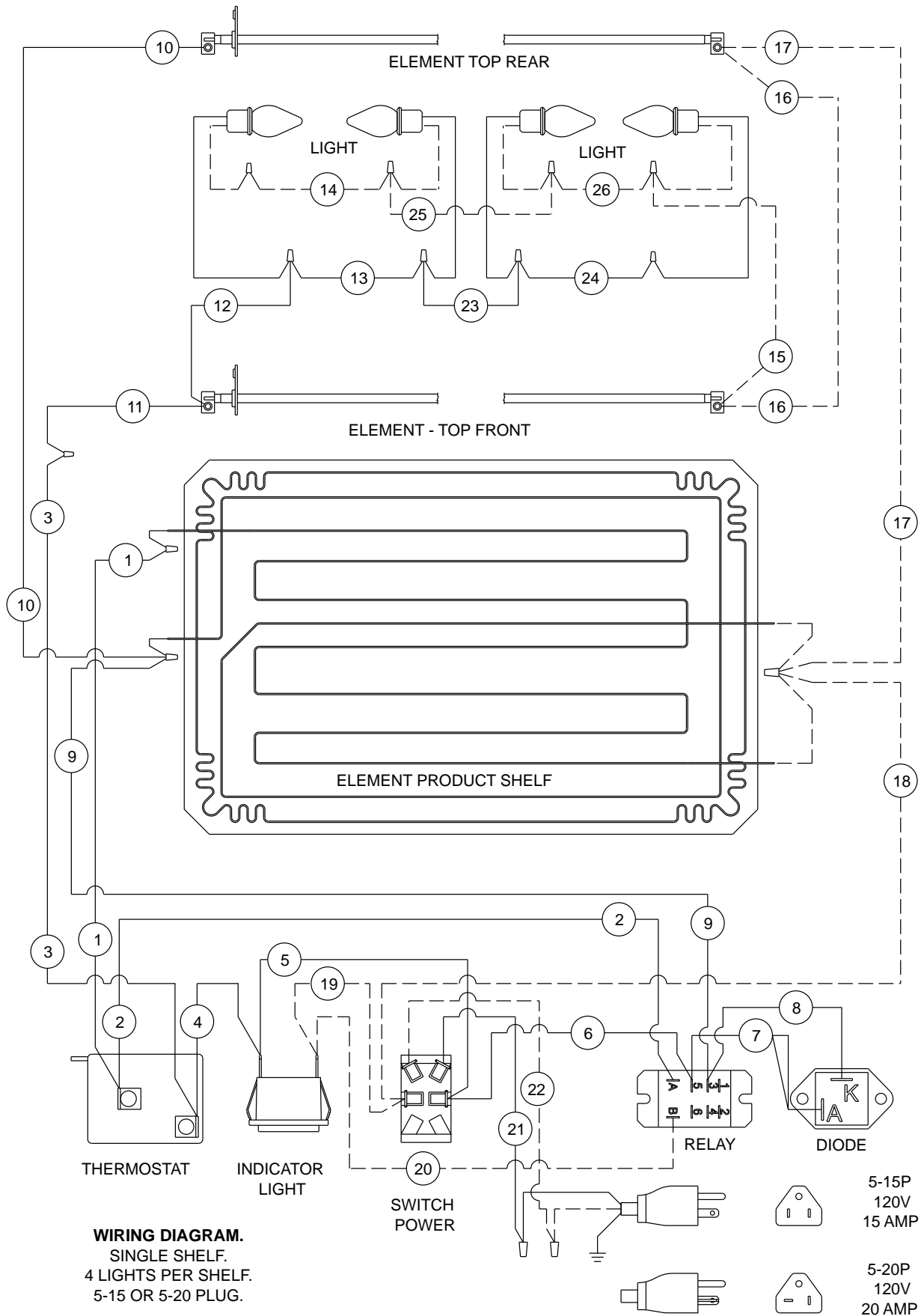

STAR MANUFACTURING INTERNATIONAL, INC.

SK2505-4 REV. -

UPPER SHELF

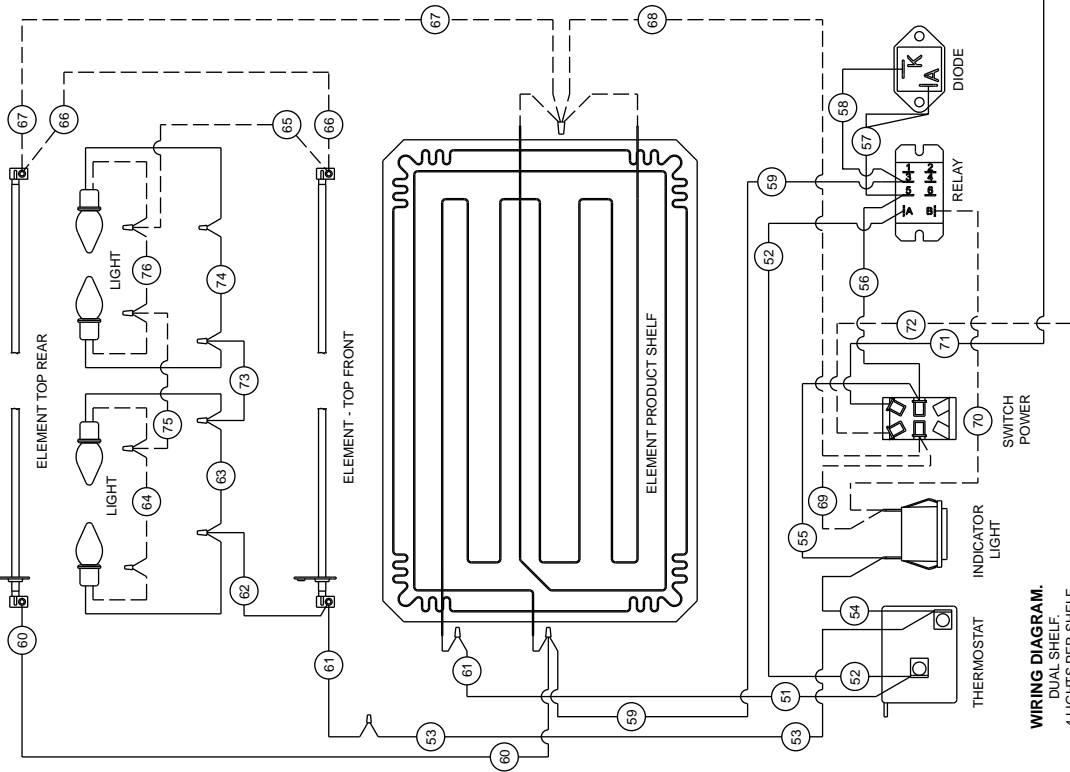

LOWER SHELF

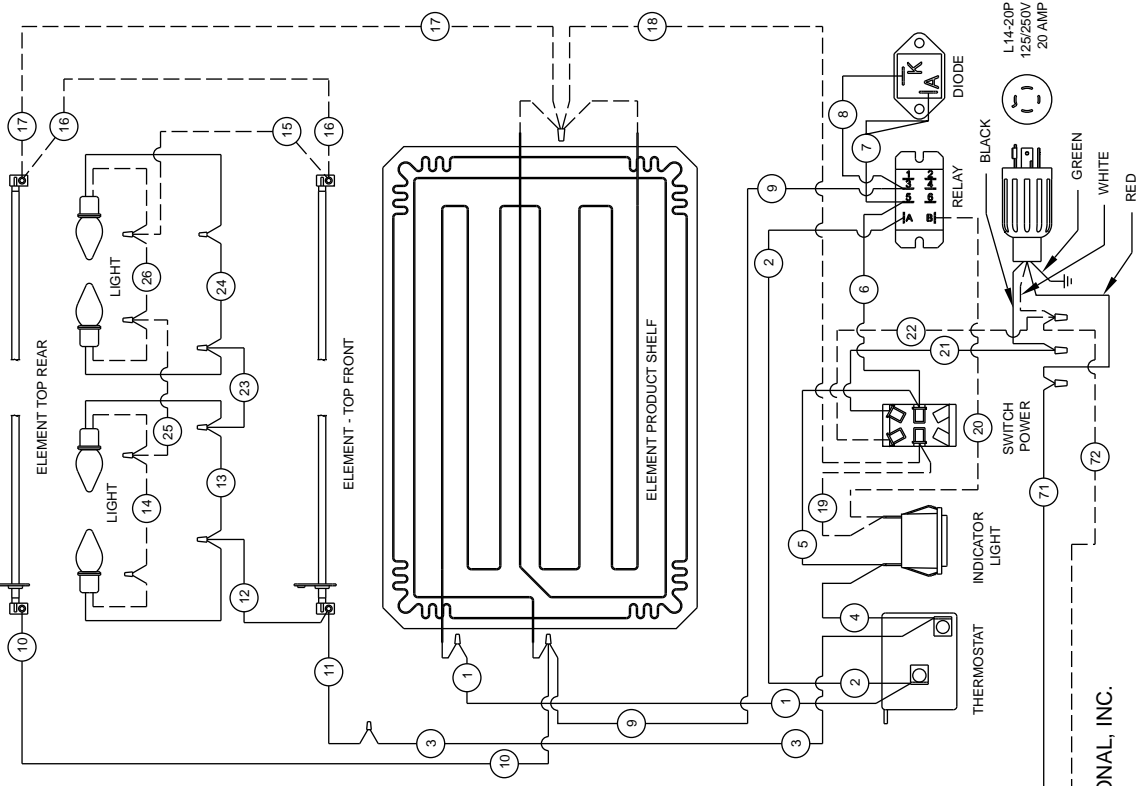

WIRING DIAGRAM.
DUAL SHELF.
4 LIGHTS PER SHELF.
L14-20 PLUG.

STAR MANUFACTURING INTERNATIONAL, INC.

SK2505-5 REV. -

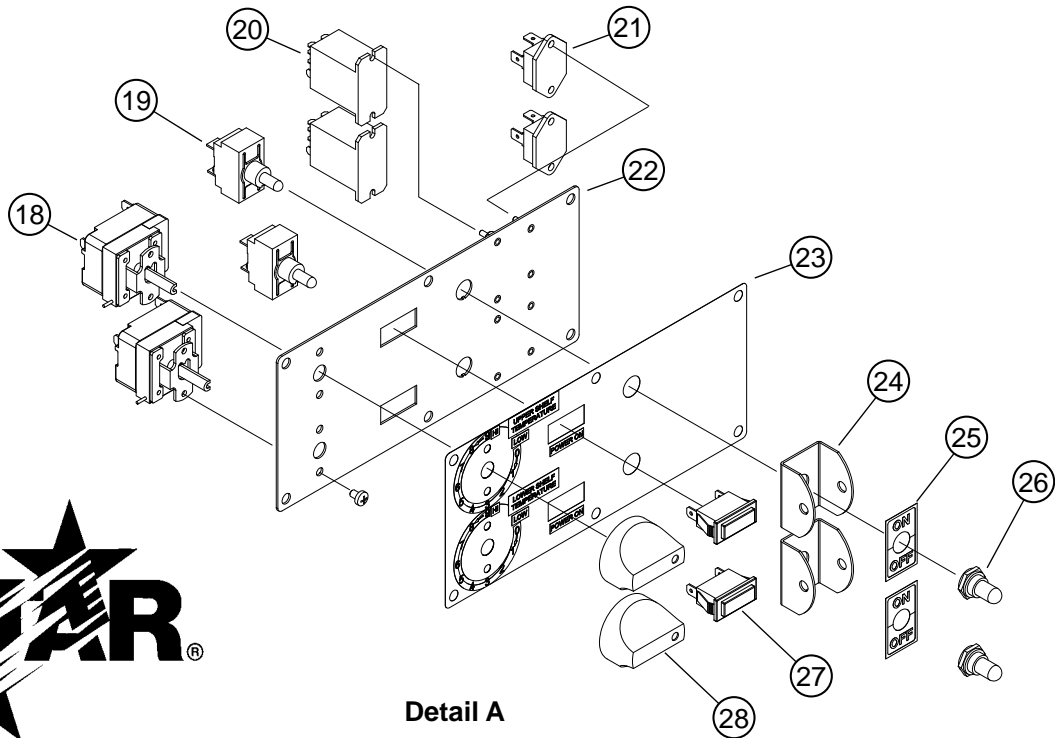
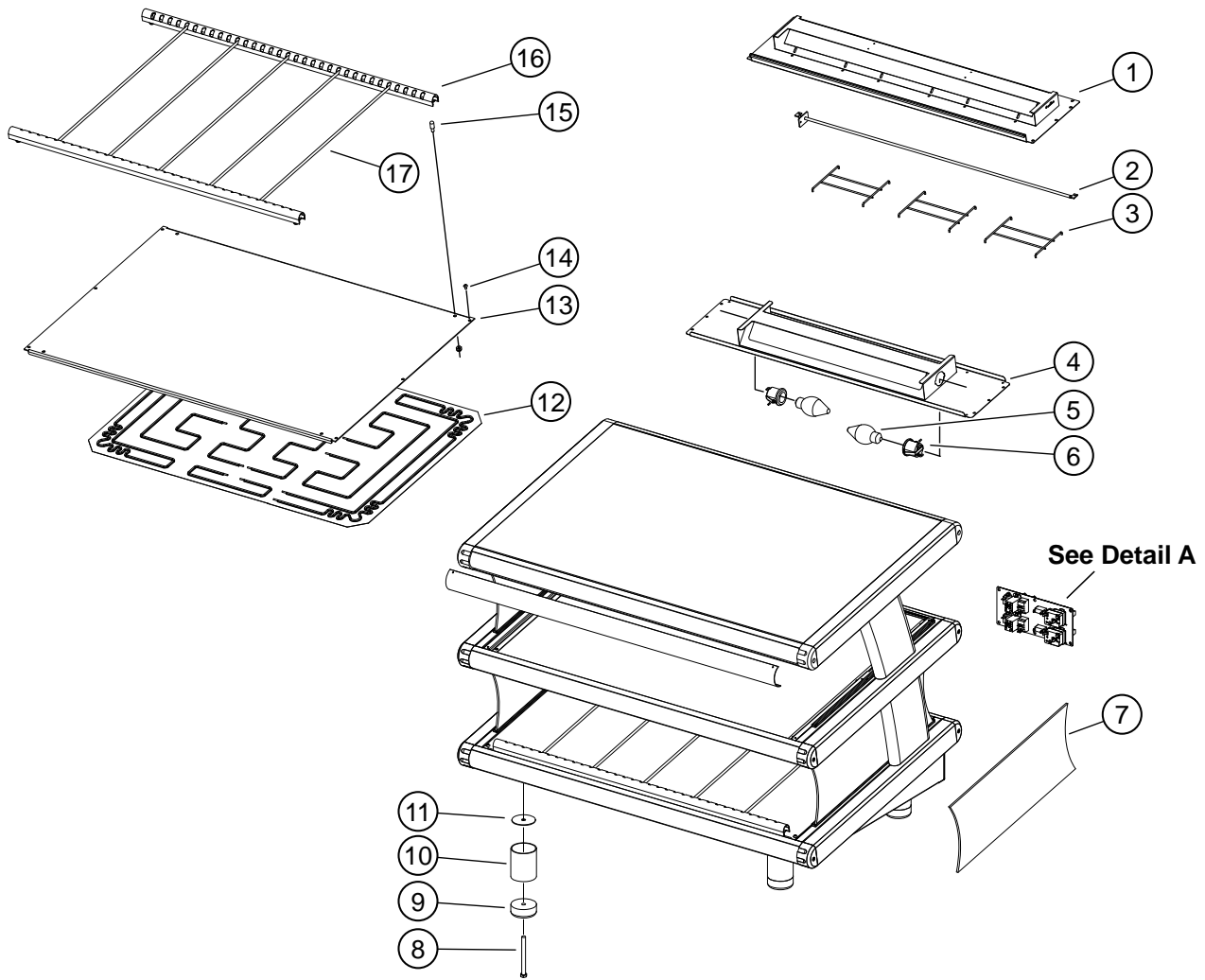

Detail A

Model: HWE24 FLAT & SLANT EURO PARTS LIST				
Fig No.	Part Number	Quantity	Description	Application
1	D5-MDW041	2	ELEMENT BAR WELD ASSY,24"	HWE24S1, HWE24H1
		4		HWE24S2, HWE24H2
2	2N-Z14166	2	ELEMENT, TOP, 120V, 175W, 24"	HWE24S1-120V, HWE24H1-120V
		4		HWE24S2-120V, HWE24H2-120V
	2N-Z14962	2	ELEMENT, TOP, 230V, 175W, 24"	HWE24S1-230V, HWE24H1-230V
		4		HWE24S2-230V, HWE24H2-230V
3	2B-Z14177	4	ELEMENT GUARD	HWE24S1, HWE24H1
		8		HWE24S2, HWE24H2
4	D5-MDW040	1	LIGHT BAR WELD ASSY.,24"	HWE24S1, HWE24H1
		2		HWE24S2, HWE24H2
5	2S-Z13988	2	LT. BULB, 120V,60W	HWE24S1-120V, HWE24H1-120V
		4		HWE24S2-120V, HWE24H2-120V
	2S-Z14986	2	LT. BULB, 60C15-240V-MED	HWE24S1-230V, HWE24H1-230V
		4		HWE24S2-230V, HWE24H2-230V
6	2E-Y5921	2	SOCKET SPRING CLIP MOUNT	HWE24S1, HWE24H1
		4		HWE24S2, HWE24H2
7	2Q-Z14447	2	GLASS, SIDE, GREY	HWE24S1, HWE24H1
		4		HWE24S2, HWE24H2
8	2C-Z14320	4	BOLT, HEX, 3/8-16UNCX1	ALL
9	2A-Z14300	4	FOOT, 2.5 DIA X 1"	ALL
12	2N-Z14571	1	HEATER, FOIL, 350W, 120V, 24"	HWE24S1-120V, HWE24H1-120V
		2		HWE24S2-120V, HWE24H2-120V
	2N-Z14966	1	ELEMENT, FOIL, 350W, 230V 24"	HWE24S1-230V, HWE24H1-230V
		2		HWE24S2-230V, HWE24H2-230V
13	D5-Z14783	1	TRAY, PRODUCT, 24" EURO	HWE24S1, HWE24H1
		2		HWE24S2, HWE24H2
14	2C-Z14444	12	SCREW, #8 X 3/8 PTH A, BL	HWE24S1
		20		HWE24H1
		24		HWE24S2
		34		HWE24H2
15	2B-Z14041	4	STUD, COMMON - DIVIDER	HWE24S1, HWE24H1
		8		HWE24S2, HWE24H2
16	D5-MDW001	2	DIVIDER ASSY - 24"	HWE24S1, HWE24H1
		4		HWE24S2, HWE24H2
17	2B-Z14042	5	DIVIDER ROD-24" DP SHELF	HWE24S1, HWE24H1
		10		HWE24S2, HWE24H2
18	2T-Z14281	1	THERMOSTAT, 85 - 195F	HWE24S1, HWE24H1
		2		HWE24S2, HWE24H2
19	2E-Z12020	1	SWITCH-TOGGLE 2P ST	HWE24S1, HWE24H1
		2		HWE24S2, HWE24H2
20	2E-Z14428	1	RELAY, DPDT, 15A, 120V COIL	HWE24S1, HWE24H1
		2		HWE24S2, HWE24H2
21	2E-Z14548	1	DIODE, POWER ISOLATING, 20A	HWE24S1, HWE24H1
		2		HWE24S2, HWE24H2
22	D5-MDW049	1	ASSY., CTRL PANEL, DUAL, EU	HWE24S2
	D5-MDW050		ASSY., CTRL PANEL, SGL, EURO	HWE24S1
	D5-MDW063		ASSY., CTL PNL, EU, DL, FL, 24"	HWE24H2
	D5-MDW069		ASSY, CTL PNL, EU, SG, FL, 24"	HWE24H1
23	2M-Z14601	1	LABEL, SINGLE SHELF TEMP	HWE24S1
	2M-Z14602		LABEL, DUAL SHELF, SLANT	HWE24S2
	2M-Z14603		LABEL, DUAL, UPPER SHELF	HWE24H2
	2M-Z14604		LABEL, DUAL, LOWER SHELF	HWE24H2
26	2I-05-07-0013	1	BOOT SWITCH	HWE24S1, HWE24H1
		2		HWE24S2, HWE24H2
27	2J-Z13654	1	PILOT LIGHT RECT-RED-120V	HWE24S1, HWE24H1
		2		HWE24S2, HWE24H2
28	2R-Z14443	1	KNOB-1.56" DIA X 1"	HWE24S1
		2		HWE24S2
29	2C-73205	2	SCREW 4MMX6MM SL PAN MS S	HWE24S1, HWE24H1
		4		HWE24S2, HWE24H2
NI	2K-Y2968	1	BUSHING - HEYCO 7W-2	ALL
NI	D5-HWP006	1	CORD SET	ALL

Model: HWE30 FLAT & SLANT EURO PARTS LIST				
Fig No	Part Number	Quantity	Description	Application
1	D5-MDW045	2	ELEMENT BAR WELD ASSY,30"	HWE30S1, HWE30H1
		4		HWE30S2, HWE30H2
2	2N-Z14167	2	ELEMENT, TOP, 120V, 225W, 30"	HWE30S1-120V, HWE30H1-120V
		4		HWE30S2-120V, HWE30H2-120V
	2N-Z14963	2	ELEMENT, TOP, 230V, 225W, 30"	HWE30S1-230V, HWE30H1-230V
		4		HWE30S2-230V, HWE30H2-230V
3	2B-Z14177	4	ELEMENT GUARD	HWE30S1, HWE30H1
		8		HWE30S2, HWE30H2
4	D5-MDW044	1	LIGHT BAR WELD ASSY, 30"	HWE30S1, HWE30H1
		2		HWE30S2, HWE30H2
5	2S-Z13988	2	LT. BULB, 120V, 60W	HWE30S1, HWE30H1
		4		HWE30S2, HWE30H2
	2S-Z14986	2	LT. BULB, 60C15-240V-MED	HWE30S1-230V, HWE30H1-230V
		4		HWE30S2-230V, HWE30H2-230V
6	2E-Y5921	2	SOCKET SPRING CLIP MOUNT	HWE30S1, HWE30H1
		4		HWE30S2, HWE30H2
7	2Q-Z14447	2	GLASS, SIDE, GREY	HWE30S1, HWE30H1
		4		HWE30S2, HWE30H2
8	2C-Z14304	4	BOLT, HEX, 3/8-16UNCX4	HWE30S2
	2C-Z14320	4	BOLT, HEX, 3/8-16UNCX1	HWE30S1, H1, H2
9	2A-Z14300	4	FOOT, 2.5 DIA X 1"	ALL
10	2V-Z14302	4	LEG, STL, 3", BLACK	ALL
11	2A-Z14303	4	WASHER, 2.3 OD X .38 ID	ALL
12	2N-Z14705	1	HEATER, FOIL, 390W, 120V, 30"	HWE30S1-120V, HWE30H1-120V
		2		HWE30S2-120V, HWE30H2-120V
	2N-Z14967	1	HEATER, FOIL, 390W, 230V, 30"	HWE30S1-230V, HWE30H1-230V
		2		HWE30S2-230V, HWE30H2-230V
13	D5-Z14784	1	TRAY, PRODUCT, 30" EURO	HWE30S1, HWE30H1
		2		HWE30S2, HWE30H2
14	2C-Z14444	12	SCREW, #8 X 3/8 PTH A, BL	HWE30S1
		20		HWE30H1
		24		HWE30S2
		34		HWE30H2
15	2B-Z14041	4	STUD, COMMON - DIVIDER	HWE30S1, HWE30H1
		8		HWE30S2, HWE30H2
16	D5-MDW002	2	DIVIDER ASSY - 30"	HWE30S1, HWE30H1
		4		HWE30S2, HWE30H2
17	2B-Z14042	6	DIVIDER ROD-24" DP SHELF	HWE30S1, HWE30H1
		12		HWE30S2, HWE30H2
18	2T-Z14281	1	THERMOSTAT, 85 - 195F	HWE30S1, HWE30H1
		2		HWE30S2, HWE30H2
19	2E-Z12020	1	SWITCH-TOGGLE 2P ST	HWE30S1, HWE30H1
		2		HWE30S2, HWE30H2
20	2E-Z14428	1	RELAY, DPDT, 15A, 120V COIL	HWE30S1, HWE30H1
		2		HWE30S2, HWE30H2
21	2E-Z14548	1	DIODE, POWER ISOLATING, 20A	HWE30S1, HWE30H1
		2		HWE30S2, HWE30H2
22	D5-MDW049	1	ASSY., CTRL PANEL, DUAL, EU	HWE30S2
	D5-MDW050		ASSY., CTRL PANEL, SGL, EURO	HWE30S1
	D5-MDW064		ASSY, CTL PNL, EU, DL, FL, 30"	HWE30H2
	D5-MDW070		ASSY, CTL PNL, EU, SG, FL, 30"	HWE30H1
23	2M-Z14601	1	LABEL, SINGLE SHELF TEMP	HWE30H1
	2M-Z14602		LABEL, DUAL SHELF, SLANT	HWE30S2
	2M-Z14603		LABEL, DUAL, UPPER, FLAT	HWE30H2
	2M-Z14604		LABEL, DUAL, LOWER SHELF	HWE30H2
26	2I-05-07-0013	1	BOOT SWITCH	HWE30S1, HWE30H1
		2		HWE30S2, HWE30H2
27	2J-Z13654	1	PILOT LIGHT RECT-RED-120V	HWE30S1, HWE30H1
		2		HWE30S2, HWE30H2
28	2R-Z14443	1	KNOB-1.56" DIA X 1"	HWE30S1, HWE30H1
		2		HWE30S2, HWE30H2
29	2C-73205	2	SCREW 4MMX6MM SL PAN MS S	HWE30S1
		4		HWE30S2
NI	2K-Y2968	1	BUSHING - HEYCO 7W-2	ALL
NI	D5-HWP006	1	CORD SET	ALL

Parts List

August 11, 2011

Model: HWE36 FLAT & SLANT EURO PARTS LIST				
Fig No.	Part Number	Quantity	Description	Application
1	D5-MDW008	2	ELEMENT BAR WELD ASSY,36"	HWE36S1, HWE36H1
		4		HWE36S2, HWE36H2
2	2N-Z14168	2	ELEMENT, TOP, 120V, 275W, 36"	HWE36S1-120V, HWE36H1-120V
		4		HWE36S2-120V, HWE36H2-120V
	2N-Z14964	2	ELEMENT, TOP, 230V, 275W, 36"	HWE36S1-120V, HWE36H1-120V
		4		HWE36S2-120V, HWE36H2-120V
3	2B-Z14177	6	ELEMENT GUARD	HWE36S1, HWE36H1
		12		HWE36S2, HWE36H2
4	D5-MDW007	1	LIGHT BAR WELD ASSY., 36"	HWE36S1, HWE36H1
		2		HWE36S2, HWE36H2
5	2S-Z13988	2	LT. BULB, 120V, 60W	HWE36S1-120V, HWE36H1-120V
		4		HWE36S2-120V, HWE36H2-120V
	2S-Z14986	2	LT. BULB, 60C15-240V-MED	HWE36S1-120V, HWE36H1-120V
		4		HWE36S2-120V, HWE36H2-120V
6	2E-Y5921	2	SOCKET SPRING CLIP MOUNT	HWE36S1, HWE36H1
		4		HWE36S2, HWE36H2
7	2Q-Z14447	2	GLASS, SIDE, GREY	HWE36S1, HWE36H1
		4		HWE36S2, HWE36H2
8	2C-Z14304	4	BOLT, HEX, 3/8-16UNCX4	ALL
9	2A-Z14300	4	FOOT, 2.5 DIA X 1"	HWE36S2, HWE36H2
10	2V-Z14302	4	LEG, STL, 3", BLACK	HWE36S2, HWE36H2
11	2A-Z14303	4	WASHER, 2.3 OD X .38 ID	HWE36S2, HWE36H2
12	2N-Z14572	1	HEATER, FOIL, 500W, 120V, 36"	HWE36S1-120V, HWE36H1-120V
		2		HWE36S2-120V, HWE36H2-120V
	2N-Z14968	1	ELEMENT, FOIL, 500W, 230V, 36"	HWE36S1-120V, HWE36H1-120V
		2		HWE36S2-120V, HWE36H2-120V
13	D5-Z14045	1	TRAY, PRODUCT, 36" EURO	HWE36S1, HWE36H1
		2		HWE36S2, HWE36H2
14	2C-Z14444	12	SCREW, #8 X 3/8 PTH A, BL	HWE36S1
		22		HWE36H1
		24		HWE36S2
		36		HWE36H2
15	2B-Z14041	4	STUD, COMMON - DIVIDER	HWE36S1
		8		HWE36S2, HWE36H2
16	D5-MDW003	2	DIVIDER ASSY - 36"	HWE36S1, HWE36H1
		4		HWE36S2, HWE36H2
17	2B-Z14042	7	DIVIDER ROD-24" DP SHELF	HWE36S1, HWE36H1
		14		HWE36S2, HWE36H2
18	2T-Z14281	1	THERMOSTAT, 85 - 195F	HWE36S1, HWE36H1
		2		HWE36S2, HWE36H2
19	2E-Z12020	1	SWITCH-TOGGLE 2P ST	HWE36S1, HWE36H1
		2		HWE36S2, HWE36H2
20	2E-Z14428	1	RELAY, DPDT, 15A, 120V COIL	HWE36S1, HWE36H1
		2		HWE36S2, HWE36H2
21	2E-Z14548	1	DIODE, POWER ISOLATING, 20A	HWE36S1, HWE36H1
		2		HWE36S2, HWE36H2
22	D5-MDW065	1	ASSY, CTL PNL, EU DL, FL 36"	HWE36H2
	D5-MDW071		ASSY, CTL PNL, EU, SG, FL 36"	HWE36H1
	D5-MDW049		ASSY, CTRL PANEL, DUAL, EU	HWE36S2
	D5-MDW050		ASSY, CTRL PANEL, SGL EURO	HWE36S1
23	2M-Z14601	1	LABEL, SINGLE SHELF TEMP	HWE36S1, HWE36H1
	2M-Z14602		LABEL, DUAL SHELF, SLANT	HWE36S2
	2M-Z14603		LABEL, DUAL, UPPER, FLAT	HWE36H2
	2M-Z14604		LABEL, DUAL, LOWER, FLAT	HWE36H2
26	2I-05-07-0013	1	BOOT SWITCH	HWE36S1, HWE36H1
		2		HWE36S2, HWE36H2
27	2J-Z13654	1	PILOT LIGHT RECT-REDV	HWE36S1, HWE36H1
		2		HWE36S2, HWE36H2
28	2R-Z14443	1	KNOB-1.56" DIA X 1"	HWE36S1, HWE36H1
		2		HWE36S2, HWE36H2
29	2C-73205	2	SCREW 4MMX6MM SL PAN MS S	HWE36S1, HWE36H1
		4		HWE36S2, HWE36H2
NI	2K-Y2968	1	BUSHING - HEYCO 7W-2	HWE36S1, HWE36H1
NI	D5-HWP006	1	CORD SET	HWE36S1, HWE36H1
NI	D5-MDW048	1	CORDSET ASSY., 12/4, L14-20	HWE36S2, HWE36H2

Model: HWE48 FLAT & SLANT EURO PARTS LIST				
Fig No	Part Number	Quantity	Description	Applications
1	D5-MDW032	2	ELEMENT BAR WELD ASSY,48"	HWE48S1, HWE48H1
		4		HWE48S2, HWE48H2
2	2N-Z14169	2	ELEMENT, TOP, 120V, 375W, 48"	HWE48S1-120V, HWE48H1-120V
		4		HWE48S2-120V, HWE48H2-120V
	2N-Z14965	2	ELEMENT, TOP, 230V, 375W, 48"	HWE48S1-230V, HWE48H1-230V
		4		HWE48S2-230V, HWE48H2-230V
3	2B-Z14177	8	ELEMENT GUARD	HWE48S1, HWE48H1
		16		HWE48S2, HWE48H2
4	D5-MDW031	1	LIGHT BAR WELD ASSY., 48"	HWE48S1, HWE48H1
		2		HWE48S2, HWE48H2
5	2S-Z13988	4	LT. BULB, 120V, 60W	HWE48S1-120V, HWE48H1-120V
		8		HWE48S2-120V, HWE48H2-120V
	2S-Z14986	4	LT. BULB, 60C15-240V-MED	HWE48S1-230V, HWE48H1-230V
		8		HWE48S2-230V, HWE48H2-230V
6	2E-Y5921	4	SOCKET SPRING CLIP MOUNT	HWE48S1, HWE48H1
		8		HWE48S2, HWE48H2
7	2Q-Z14447	2	GLASS, SIDE, GREY	HWE48S1, HWE48H1
		4		HWE48S2, HWE48H2
8	2C-Z14304	4	BOLT, HEX, 3/8-16UNCX4	ALL
9	2A-Z14300	4	FOOT, 2.5 DIA X 1"	ALL
10	2V-Z14302	4	LEG, STL, 3", BLACK	ALL
11	2A-Z14303	4	WASHER, 2.3 OD X .38 ID	ALL
12	2N-Z14573	1	HEATER, FOIL, 650W, 120V, 48"	HWE48S1-120V, HWE48H1-120V
		2		HWE48S2-120V, HWE48H2-120V
	2N-Z14969	1	ELEMENT, FOIL, 650W 230V, 48"	HWE48S1-230V, HWE48H1-230V
		2		HWE48S2-230V, HWE48H2-230V
13	D5-Z14046	1	TRAY, PRODUCT, 48" EURO	HWE48S1, HWE48H1
		2		HWE48S2, HWE48H2
14	2C-Z14444	12	SCREW, #8 X 3/8 PTH A, BL	HWE48S1
		24		HWE48S2, HWE48H1
		38		HWE48H2
15	2B-Z14041	4	STUD, COMMON - DIVIDER	HWE48S1, HWE48H1
		8		HWE48S2, HWE48H2
16	D5-MDW004	2	DIVIDER ASSY - 48"	HWE48S1, HWE48H1
		4		HWE48S2, HWE48H2
17	2B-Z14042	8	DIVIDER ROD-24" DP SHELF	HWE48S1, HWE48H1
		16		HWE48S2, HWE48H2
18	2T-Z14281	1	THERMOSTAT, 85 - 195F	HWE48S1, HWE48H1
		2		HWE48S2, HWE48H2
19	2E-Z12020	1	SWITCH-TOGGLE 2P ST	HWE48S1, HWE48H1
		2		HWE48S2, HWE48H2
20	2E-Z14428	1	RELAY, DPDT, 15A, 120V COIL	HWE48S1, HWE48H1
		2		HWE48S2, HWE48H2
21	2E-Z14548	1	DIODE, POWER ISOLATING, 20A	HWE48S1, HWE48H1
		2		HWE48S2, HWE48H2
22	D5-MDW049	1	ASSY., CTRL PANEL, DUAL, EU	HWE48S2
	D5-MDW050		ASSY, CTRL PANEL, SGL, EURO	HWE48S1
	D5-MDW072		ASSY, CTL PNL, EU, SG, FL, 48"	HWE48H1
	D5-MDW066		ASSY, CTL PNL, EU, SG, FL, 48"	HWE48H2
23	2M-Z14601	1	LABEL, SINGLE SHELF TEMP	HWE48S1, HWE48H1
	2M-Z14602		LABEL, DUAL SHELF, SLANT	HWE48S2
	2M-Z14603		LABEL, DUAL, UPPER, FLAT	HWE48H2
	2M-Z14604		LABEL, DUAL, LOWER SHELF	HWE48H2
26	2I-05-07-0013	1	BOOT SWITCH	HWE48S1, HWE48H1
		2		HWE48S2, HWE48H2
27	2J-Z13654	1	PILOT LIGHT RECT-RED-120V	HWE48S1, HWE48H1
		2		HWE48S2, HWE48H2
28	2R-Z14443	1	KNOB-1.56" DIA X 1"	HWE48S1, HWE48H1
		2		HWE48S2, HWE48H2
29	2C-73205	2	SCREW 4MMX6MM SL PAN MS S	HWE48S1, HWE48H1
		4		HWE48S2, HWE48H2
NI	2K-Y2968	2	BUSHING - STRAIN RELIEF	HWE48S1, HWE48H1
NI	D5-HWP006	1	CORD SET	HWE48S1, HWE48H1
NI	D5-MDW048	1	CORDSET ASSY., 12/4, L14-20	HWE48S2, HWE48H2