



**Star  
Manufacturing  
International Inc.**

10 Sunnen Drive  
St. Louis, MO 63143

Phone: (314) 781-2777  
FAX: (314) 781-2714

**Installation  
and  
Operating  
Instructions**

2M-Z2665 REV. B 2/16/06

# **SNEEZE GUARDS 1 DOOR/2 DOOR MODELS**

**20SG-1D**

**20SG-2D**

**25SG-FCA**

**30SG-1D**

**30SG-2D**

**45SG-1D**

**45SG-2D**

**45SG-FCA**

**50SG-1D**

**50SG-2D**

**75SG-1D**

**75SG-2D**

**75SG-FCA**



### THOROUGHLY INSPECT YOUR UNIT ON ARRIVAL

This unit has been tested for proper operation before leaving our plant to insure delivery of your unit in perfect condition. However, there are instances in which the unit may be damaged in transit. In the event you discover any type of damage to your product upon receipt, you must immediately contact the transportation company who delivered the item to you and initiate your claim with same. If this procedure is not followed, it may affect the warranty status of the unit.

### LIMITED EQUIPMENT WARRANTY

All workmanship and material in Star products have a one (1) year limited warranty on parts & labor in the United States and Canada. Such warranty is limited to the original purchaser only and shall be effective from the date the equipment is placed in service. Star's obligation under this warranty is limited to the repair of defects without charge, by the factory authorized service agency or one of its sub-agencies. Models that are considered portable (*see below*) should be taken to the closest Star service agency, transportation prepaid.

- > Star will not assume any responsibility for loss of revenue.
- > On all shipments outside the United States and Canada, see International Warranty.
- \* The warranty period for the JetStar six (6) ounce & Super JetStar eight (8) ounce series popcorn machines is two (2) years.
- \* The warranty period for the Chrome-Max Griddles is five (5) years on the griddle surface. See detailed warranty provided with unit.
- \* The warranty period for Teflon/Dura-Tec coatings is one year under normal use and reasonable care. This warranty does not apply if damage occurs to Teflon/Dura-Tec coatings from improper cleaning, maintenance, use of metallic utensils, or abrasive cleaners, abrasive pads, product identifiers and point-of-sale attachments, or any other non-food object that comes in continuous contact with the roller coating. This warranty does not apply to the "non-stick" properties of such materials.
- > This warranty does not apply to "Special Products" but to regular catalog items only. Star's warranty on "Special Products" is six (6) months on parts and ninety (90) days on labor.
- > This warranty does not apply to any item that is disassembled or tampered with for any purpose other than repair by a Star Authorized Service Center or the Service Center's sub-agency.
- > This warranty does not apply if damage occurs from improper installation, misuse, wrong voltage, wrong gas or operated contrary to the Installation and Operating instructions.
- > This warranty is not valid on Conveyor Ovens *unless* a "start-up/check-out" has been performed by a Factory Authorized Technician.

### PARTS WARRANTY

Parts that are sold to repair out of warranty equipment are warranted for ninety (90) days. The part only is warranted. Labor to replace the part is chargeable to the customer.

### SERVICES NOT COVERED BY WARRANTY

1. Travel time and mileage rendered beyond the 50 mile radius limit
2. Mileage and travel time on portable equipment (*see below*)
3. Labor to replace such items that can be replaced easily during a daily cleaning routine, ie; removable kettles on fryers, knobs, grease drawers on griddles, etc.
4. Installation of equipment
5. Damages due to improper installation
6. Damages from abuse or misuse
7. Operated contrary to the Operating and Installation Instructions
8. Cleaning of equipment
9. Seasoning of griddle plates
10. Voltage conversions
11. Gas conversions
12. Pilot light adjustment
13. Miscellaneous adjustments
14. Thermostat calibration and by-pass adjustment
15. Resetting of circuit breakers or safety controls or reset buttons
16. Replacement of bulbs
17. Replacement of fuses
18. Repair of damage created during transit, delivery, & installation OR created by acts of God

### PORTABLE EQUIPMENT

Star will not honor service bills that include travel time and mileage charges for servicing any products considered "Portable" including items listed below. These products should be taken to the Service Agency for repair:

- \* The Model 510FD Fryer.
- \* The Model 526TOA Toaster Oven.
- \* The Model J4R, 4 oz. Popcorn Machine.
- \* The Model 518CMA & 526CMA Cheese Melter.
- \* The Model 12MC & 15MC & 18MCP Hot Food Merchandisers.
- \* The Model 12NCPW & 15NCPW Nacho Chip/Popcorn Warmer.
- \* All Hot Dog Equipment **except Roller Grills & Drawer Bun Warmers.**
- \* All Nacho Cheese Warmers **except Model 11WLA Series Nacho Cheese Warmer.**
- \* All Condiment Dispensers **except the Model HPD & SPD Series Dispenser.**
- \* All Specialty Food Warmers **except Model 130R, 11RW Series, and 11WSA Series.**
- \* All QCS/RCS Series Toasters **except Model QCS3 & RCS3 Series.**

#### ALL:

- \* Pop-Up Toasters
- \* Butter Dispensers
- \* Pretzel Merchandisers  
(Model 16PD-A Only)
- \* Pastry Display Cabinets
- \* Nacho Chip Merchandisers
- \* Accessories of any kind
- \* Sneeze Guards
- \* Pizza Ovens  
(Model PO12 Only)
- \* Heat Lamps
- \* Pumps-Manual

The foregoing warranty is in lieu of any and all other warranties expressed or implied and constitutes the entire warranty.

### FOR ASSISTANCE

Should you need any assistance regarding the Operation or Maintenance of any Star equipment; write, phone, fax or email our Service Department. In all correspondence mention the Model number and the Serial number of your unit, and the voltage or type of gas you are using.

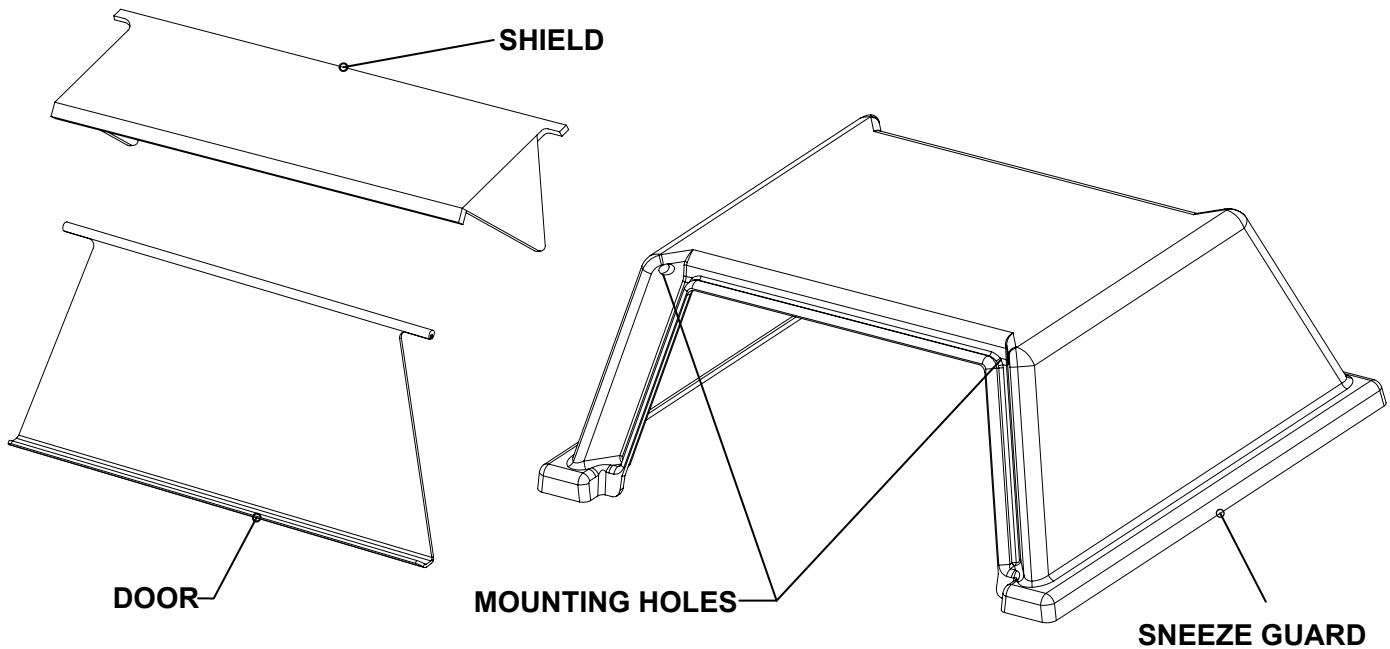

Before installing sneeze guard on unit, remove all protective plastic wrap and discard.

### **Installing Doors or Shields**

Insert one tab of the door or shield into the sneeze guard hole. Flex the door or shield and insert the other tab into the other hole.

**WARNING:** Since the sneeze guard becomes hot during operation, let it cool completely before removing doors or shields

### **CLEANING SNEEZE GUARDS**

Wash the sneeze guards with a mild soap or detergent and lukewarm water, using a clean sponge or a soft cloth. Rinse well with clean water.

Dry thoroughly with a moist sponge to prevent water spots.

**DO NOT** use harsh chemicals on any surface

**DO NOT** scrub or use brushes on the sneeze guards

**DO NOT** use abrasive cleaners on the sneeze guards

**DO NOT** scrape the sneeze guards with squeegees or sharp instruments

**DO NOT** clean sneeze guards at elevated temperatures

### **MODELS:**

**20, 30, 45, 45A, 50, 75, 75A SNEEZE GUARDS**



**STAR MANUFACTURING INTERNATIONAL, INC.**

**2M-Z2665**

**Rev. B**

**2-16-06**

# PARTS LIST

February 16, 2006, Rev B

MODELS See Kit Part Number

Kit Part Number	Part Number	Quantity	Description
20SG-1D	2L-Z2339	1	SNEEZE GUARD
	2Q-Z2341	1	DOOR
20SG-2D	2L-Z2340	1	SNEEZE GUARD
	2Q-Z2341	2	DOOR
25SG-FCA	2L-Z3165	1	SNEEZE GUARD
	2Q-Z3170	2	DOOR 25SG-FCA
30SG-1D	2L-Z2344	1	SNEEZE GUARD
	2Q-Z2346	1	DOOR
30SG-2D	2L-Z2345	1	SNEEZE GUARD
	2Q-Z2346	2	DOOR
45SG-1D	2L-Z2349	1	SNEEZE GUARD
	2Q-Z2346	1	DOOR
45SG-2D	2L-Z2350	1	SNEEZE GUARD
	2Q-Z2346	2	DOOR
45SG-FCA	2L-Z3166	1	SNEEZE GUARD 45 RETRO
	2Q-Z3171	2	DOOR 45/75 FCA
50SG-1D	2L-Z2352	1	SNEEZE GUARD
	2Q-Z2354	1	DOOR
50SG-2D	2L-Z2353	1	SNEEZE GUARD
	2Q-Z2354	2	DOOR
75SG-1D	2L-Z2357	1	SNEEZE GUARD
	2Q-Z2354	1	DOOR
75SG-2D	2L-Z2358	1	SNEEZE GUARD
	2Q-Z2354	2	DOOR
75SG-FCA	2L-Z3167	1	SNEEZE GUARD 75 RETRO
	2Q-Z3171	2	DOOR 45/75 FCA

**IMPORTANT: WHEN ORDERING, SPECIFY VOLTAGE OR TYPE GAS DESIRED  
INCLUDE MODEL AND SERIAL NUMBER**

PAGE 1  
OF 1

Some items are included for illustrative purposes only and in certain instances may not be available.



**Star Manufacturing International, Inc.**