



## Flake Ice Machine Installation, Use & Care Manual

This manual is updated as new information and models are released.  
Visit our website for the latest manual. [www.manitowocice.com](http://www.manitowocice.com)

# Table of Contents

---

## Section 1

### General Information

Model Numbers .....	3
---------------------	---

## Section 2

### Installation Instructions

Location of Ice Machine .....	4
Clearance Requirements .....	4
Installation Requirements .....	4
RF-2300 Bin Adapter Installation .....	4
Water and Drain Requirements .....	5
Potable Water Requirements .....	5
Water Supply and Drain Line Sizing/Connections .....	5
Drain Connections .....	5
Electrical Requirements .....	6
Fuse/Circuit Breaker .....	6
Ground Fault Interrupter Circuit (GFCI) .....	6

## Section 3

### Operation

Evaporator Low Temperature Safety Thermostat and Bin Thermostat .....	7
RF-0244/RF0266/RF-0388/RF0399 Operation .....	7
RF-0300 Operation .....	7
RF-650/RF-1200/RF-2300 Operation .....	7

## Section 4

### Maintenance

Interior Cleaning and Sanitizing .....	8
Cleaning/Sanitizing Procedure .....	8
Heavily Scaled Cleaning Procedure .....	8
Exterior Cleaning .....	8
Cleaning/Sanitizing Procedure .....	8
Procedure to Clean Heavily Scaled Flake Ice Machines .....	9
Removal of Parts for Cleaning/Sanitizing .....	10
Ice Chute Removal .....	10
Ice Chute Switch Actuator Removal .....	11
Air-Cooled Condenser Cleaning .....	11
Arctic Pure Water Filter System .....	11
Manitowoc Cleaner and Sanitizer .....	11

## Section 5

### Customer Support

Before Calling For Service Checklist .....	12
Commercial Ice Machine Warranty .....	13
Residential Ice Machine Limited Warranty .....	14
C Model Bin Limited Warranty .....	15

# Section 1

## General Information

---

 **Warning**

**PERSONAL INJURY POTENTIAL**

Do not operate equipment that has been misused, abused, neglected, damaged, or altered/modified from that of original manufactured specifications.

This appliance is not intended for use by persons (including children) with reduced physical, sensory or mental capabilities, or lack of experience and knowledge, unless they have been given supervision concerning use of the appliance by a person responsible for their safety.

### Model Numbers

This manual covers the following models:

Model	Self-Storage	Modular
RF-0244	X	
RF-0266	X	
RF-0388	X	
RF-0399	X	
RF-0300		X
RF-0650		X
RF-1200		X
RF-2300		X

# Section 2

## Installation Instructions

### Location of Ice Machine

The location selected for the ice machine must meet the following criteria. If any of these criteria are not met, select another location.

- The location must be free of airborne and other contaminants.
- The air temperature must be at least 50°F (10°C), but must not exceed 110°F (43°C).
- The water temperature must be at least 40°F (4°C), but must not exceed 90°F (32°C).
- The location must not be near heat-generating equipment or in direct sunlight.
- The location must be capable of supporting the weight of the ice machine and a full bin of ice.
- The location must allow enough clearance for water, drain and electrical connections in the rear of the ice machine.
- The location must not obstruct airflow through or around the ice machine.

### CLEARANCE REQUIREMENTS

RF-0244 RF-0266 RF-0388 RF-0399	Air-Cooled	Water-Cooled
Top/Sides	8" (20 cm)	8" (20 cm)
Back	5" (13 cm)	5" (13 cm)
NOTE: Allowance must be made for removal when the ice machine is built in. Monthly removal of the top panel is required for cleaning & sanitizing.		

RF-0300 RF-0650 RF-1200 RF-2300	Air-Cooled	Water-Cooled
Top/Sides	8" (20 cm)	8" (20 cm)
Back	5" (13 cm)	5" (13 cm)

### Installation Requirements

- The ice machine and bin must be level.
- Vent the ice machine and bin drains separately.
- Bin drain termination must have an air gap.
- A backflow preventer is required on water inlet lines.
- The ice machine and bin must be sanitized after installation.
- Local water conditions may require treatment of the water to inhibit scale formation, filter sediment, and remove chlorine odor and taste.
- Routine adjustments and maintenance procedures outlined in this manual are not covered by the warranty.

### RF-2300 Bin Adapter Installation

**⚠ Warning**  
**PERSONAL INJURY POTENTIAL**

RF-2300 ice machines are not approved for use on B970 bins. RF-2300 ice machines ship with a bracket that must be used when installing on B1100 and B1400 Series bins.

1. Refer to diagram. Place bracket on bin top and slide back to engage.
2. Place ice machine on bin: ice machine must fit between bracket and front ridge.

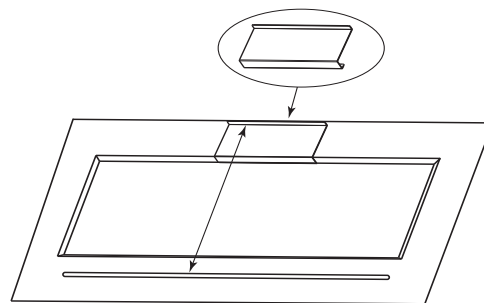

**Water and Drain Requirements**

**POTABLE WATER REQUIREMENTS**

Follow these guidelines to install water inlet lines:

- Do not connect the ice machine to a hot water supply. Be sure all hot water restrictors installed for other equipment are working. (Check valves on sink faucets, dishwashers, etc.)
- If water pressure exceeds the maximum of 80 psig (6 bar) recommended pressure, obtain a water pressure regulator from your Manitowoc distributor.
- Install a water shut-off valve and union for both the ice making and condenser water lines.
- Insulate water inlet lines to prevent condensation.
- Plumbing must conform to local codes.

**WATER SUPPLY AND DRAIN LINE SIZING/ CONNECTIONS**

Location	Water Temp Min/Max	Water Pressure Min/Max	Fitting/Min Tubing Size
Potable Water Inlet	40°/90°F (4°/32°C)	14/80 psi (100/552 kPA)	3/8" FPT
Condenser Water Inlet	40°/90°F (4°/32°C)	20/150 psi (138/1034 kPA)	1/2" FPT
Condenser Water Drain	---	---	1/2" FPT
Bin Drain	---	---	3/4" FPT
Large Capacity Bin Drain	---	---	1" FPT

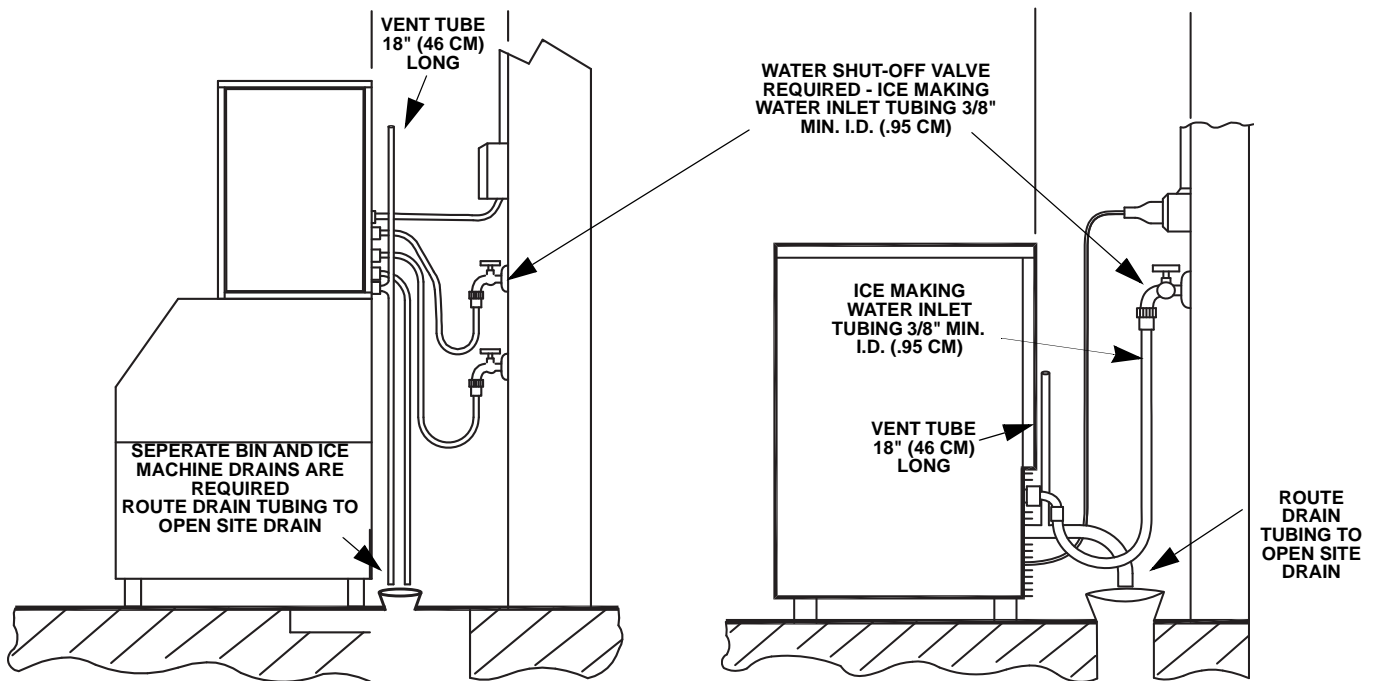

Typical Water Supply Drain Installation

**DRAIN CONNECTIONS**

Follow these guidelines when installing drain lines to prevent drain water from flowing back into the ice machine and storage bin:

- Drain lines must have a 1.5 inch drop per 5 feet of run (2.5 cm per meter), and must not create traps.
- The floor drain must be large enough to accommodate drainage from all drains.
- Run separate bin and water-cooled condenser drain lines. Insulate them to prevent condensation.
- Vent the bin and ice machine drain to the atmosphere. The ice machine drain requires an 18" (46 cm) vent. Do not vent the condenser drain on water-cooled models.
- Drains must have a union or other suitable means to allow in place disconnection from the ice machine when servicing is required.

Electrical Requirements

Ice Machine	Voltage/ Phase/ Cycle	Air-Cooled			Water-Cooled		
		Maximum Fuse/Circuit Breaker	Minimum Circuit Amps	Total Circuit Amps	Maximum Fuse/Circuit Breaker	Minimum Circuit Amps	Total Circuit Amps
RF-0244	115/1/60	15 Amp	N/A	7.5	N/A	N/A	N/A
	230/1/50	10 Amp	N/A	.87	N/A	N/A	N/A
RF-0266	115/1/60	15 Amp	N/A	7.5	N/A	N/A	N/A
	230/1/50	10 Amp	N/A	.87	N/A	N/A	N/A
RF-0388	115/1/60	15 Amp	N/A	10.0	N/A	N/A	N/A
	230/1/50	10 Amp	N/A	2.9	N/A	N/A	N/A
RF-0399	115/1/60	15 Amp	N/A	10.0	N/A	N/A	N/A
	230/1/50	10 Amp	N/A	2.9	N/A	N/A	N/A
RF-0300	115/1/60	15 Amp	10.0	N/A	N/A	N/A	N/A
	230/1/50	10 Amp	2.9	N/A	N/A	N/A	N/A
RF-0650	208-230/1/60	15 Amp	7.3	N/A	N/A	N/A	N/A
	230/1/50	16 Amp	4.6	N/A	N/A	N/A	N/A
RF-1200	208-230/1/60	15 Amp	15.0	N/A	15 Amp	15.0	N/A
	230/1/50	16 Amp	7.3	N/A	16 Amp	7.3	N/A
RF-2300	208-230/3/60	20 Amp	15.0	N/A	20 Amp	15.0	N/A
	400-415/3/50	16 Amp	13.9	N/A	16 Amp	13.9	N/A

Maximum allowable voltage variation at compressor start-up is ±10% of voltage listed above and on the model/serial plate.

FUSE/CIRCUIT BREAKER

A dedicated circuit and a separate fuse/circuit breaker are required for each ice machine.



**Warning**

The ice machine must be grounded in accordance with national and local electrical codes.

GROUND FAULT INTERRUPTER CIRCUIT (GFCI)

We do not recommend the use of a GFCI/GFI circuit protection with our equipment. If a GFCI/GFI is required by code, use a GFCI/GFI breaker rather than outlet which is more prone to intermittent nuisance trips than panel circuit breakers.

**For United Kingdom Only**

As the colours of the wires in the mains lead of the appliance may not correspond with the coloured markings identifying the terminals in your plug, proceed as follows:

- The wire which is coloured green and yellow must be connected to the terminal in the plug which is marked with the letter E or by the earth ground symbol or coloured green or green and yellow.
- The wire coloured blue must be connected to the terminal which is marked with the letter N or coloured black.
- The wire coloured brown must be connected to the terminal which is marked with the letter L or coloured red.

# Section 3 Operation

NOTE: Flake ice machines use an auger to remove ice from the evaporator. Occasional noises (creaks, groans, squeaks, or pops) are a normal part of the ice making process.

## Evaporator Low Temperature Safety Thermostat and Bin Thermostat

The bin thermostat sensing bulb is located in the ice chute or bin and turns the ice machine on and off as the level of ice in the ice chute or bin changes.

Model	Bin Thermostat Setting	Evaporator Thermostat Setting
RF-0244/RF0266/RF	5	5
RF-0388/RF-399	5	7
RF0300	4	7
RF0650	4	N/A
RF1200/RF-2300	5	N/A

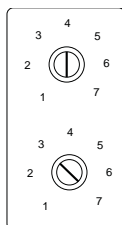

**BIN THERMOSTAT**  
SMALL NUMBERS = LESS ICE IN BIN  
LARGE NUMBERS = MORE ICE IN BIN

**EVAPORATOR LOW TEMPERATURE SAFETY THERMOSTAT**  
INCORRECT SETTINGS WILL CAUSE ICE MACHINE TO SHUT OFF

## RF-0244/RF0266/RF-0388/RF0399 Operation

The ice machine will not start until:

- The rocker switch is moved to "ON".
- Ice does not contact the bin thermostat bulb.
- The water reservoir is full of water.

Placing the toggle switch in the ON position starts the gear motor and refrigeration system. The float valve controls the water inlet valve and water level. The freeze cycle ends when ice contacts the bin thermostat. The ice machine will restart when ice no longer contacts the bin thermostat.

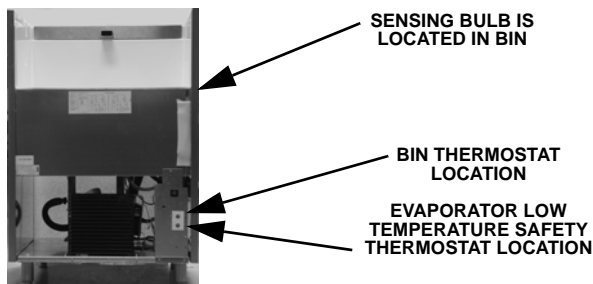

## RF-0300 Operation

The ice machine will not start until:

- The rocker switch is moved to "ON".
- Ice does not contact the bin thermostat bulb.
- The water reservoir is full of water.

Placing the toggle switch in the ON position starts the gear motor and a 10 minute compressor time delay. The compressor starts and the float valve controls the water inlet valve and water level. The freeze cycle ends when ice contacts the bin thermostat. The ice machine remains off until ice no longer contacts the bin thermostat.

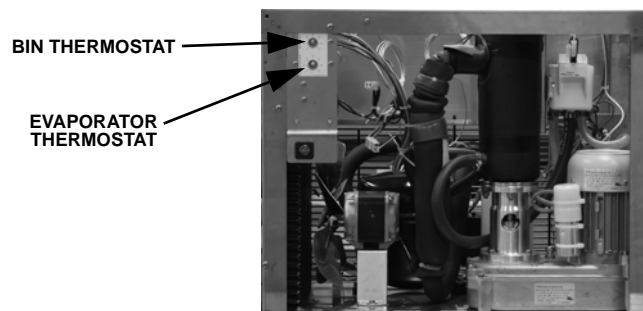

## RF-650/RF-1200/RF-2300 Operation

The ice machine will not start until:

- The rocker switch is moved to "ON".
- Ice does not contact the bin thermostat bulb.
- The water reservoir is full of water.

Placing the toggle switch in the ON position starts the gear motor. After the rotation speed sensor verifies 10 minutes of correct rotation, the time delay ends and the compressor starts. The ice machine will continue to make ice until ice contacts the bin thermostat. The ice machine remains off until ice no longer contacts the bin thermostat.



# Section 4

## Maintenance

### Interior Cleaning and Sanitizing

Maintenance procedures covered in this manual are not covered by the warranty.

#### Caution

Use only Manitowoc approved Nickel Safe Ice Machine Cleaner (part number 000000084) and Sanitizer (part number 94-0565-3). Do not mix Cleaner and Sanitizer solutions together. It is a violation of Federal law to use these solutions in a manner inconsistent with their labeling. Read and understand all labels printed on bottles before use.

#### Warning

Wear rubber gloves and safety goggles (and/or face shield) when handling Ice Machine Cleaner or Sanitizer.

### CLEANING/SANITIZING PROCEDURE

This procedure must be performed once every month.

- All ice must be removed from the bin.
- The ice machine and bin must be disassembled cleaned and sanitized.
- The ice machine produces ice with the cleaner and sanitizer solutions.
- All ice produced during the cleaning and sanitizing procedure must be discarded.

### HEAVILY SCALED CLEANING PROCEDURE

Perform this procedure if you have some or all of these symptoms.

- Grinding, popping or squealing noises from the evaporator.
- Grinding noise from gearbox.
- Ice machine trips speed sensor.

NOTE: A Cleaning/Sanitizing Procedure must be performed after this procedure.

### Exterior Cleaning

Remove dust and dirt off exterior surfaces with mild household dishwashing detergent and warm water. Wipe dry with a clean, soft cloth.

### Cleaning/Sanitizing Procedure

Use Nickel Safe Ice Machine Cleaner, part number 000000084.

Use Ice Machine Sanitizer part number 94-0565-3.

**Step 1** Remove front and top covers and set the toggle switch to the OFF position.

**Step 2** Remove all ice from the bin.

**Step 3** Turn off the ice making water supply and drain water from evaporator and reservoir.

**Step 4** Remove the top cover from water reservoir.

**Step 5** Follow the chart and premix cleaner and water.

Amount of Water	Amount of Nickel Safe Cleaner - Part Number 000000084
1 gallon (4 Liters)	3 ounces (90 ml)

**Step 6** Fill the evaporator and reservoir with cleaning solution.

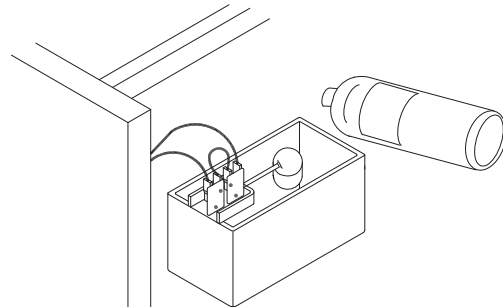

**Step 7** Move the toggle switch to the ON position. The ice machine will make ice with the cleaning solution and deposit the ice in the bin. Add the remaining cleaner/water solution as the water level in the reservoir drops.

NOTE: Do not allow the cleaner/water level to drop below the minimum water level. The ice machine will discontinue the cleaning cycle if the water float switch opens.

**Step 8** After all of the cleaner/water solution has been added, turn on the ice making water supply. Continue the freeze cycle for 10 minutes to remove the cleaning solution from the water circuit.

**Step 9** Place the toggle switch in the OFF position.



**Step 10** Refer to disassembly for cleaning/sanitizing and remove parts for hand cleaning/sanitizing.

- Hand clean all parts.
- Rinse all parts with clear potable water.
- Sanitize all parts — do not rinse after sanitizing.
- Spray all interior bin surfaces with sanitizer (do not rinse sanitized areas).
- Spray evaporator discharge spout.

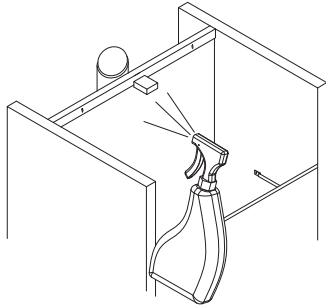

**Step 11** Reassemble ice machine.

**Step 12** Turn off the ice making water supply.

**Step 13** Refer to chart and premix water and sanitizer.

Amount of Water	Amount of Sanitizer
1 Gallons (4 L) Water	1/2 ounce (15 ml)

**Step 14** Fill the evaporator and reservoir with sanitizer/water solution.

**Step 15** Move the toggle switch to the ON position. The ice machine will make ice with the sanitizer/water solution and deposit the ice in the bin. Add the remaining sanitizer/water solution when the water level in the reservoir drops.

NOTE: Do not allow the sanitizer/water level to drop below the minimum water level. The ice machine will discontinue the cleaning cycle if the water float switch opens.

**Step 16** After all of the sanitizer/water solution has been added to the reservoir, turn on the ice making water supply.

**Step 17** Continue the freeze cycle for 30 minutes and then discard all ice produced.

**Procedure to Clean Heavily Scaled Flake Ice Machines**

**Step 1** Remove front and top covers and set the toggle switch to the OFF position.

**Step 2** Remove all ice from the bin.

**Step 3** Turn off the ice making water supply.

**Step 4** Remove the top cover from water reservoir.

**Step 5** Refer to chart below:

**Premix cleaner with lukewarm water in a non-metallic container.**

Model	Water Reservoir Capacity	Mix Cleaner and Water Use ice machine nickel safe cleaner, part number 00000084 only	
		Cleaner	Water
RF-0244 RF-0266 RF-388 RF-399	14 oz (400 ml)	9 oz (266 ml)	5 oz (148 ml)
RF-0300 RF-0650	17 oz (500 ml)	11 oz (325 ml)	6 oz (177 ml)
RF-1200	34 oz (1 L)	23 oz (680 ml)	11 oz (325 ml)
RF-2300	68 oz (2 L)	46 oz (1.3 L)	22 oz (650 ml)

**Step 6** Remove all water from the evaporator and water reservoir. Add the entire cleaner/water solution and re-install the reservoir cover.

**Leave the cleaner/water solution in the evaporator for a minimum of 4 hours.**

**Step 7** Remove all cleaner/water from the evaporator and water reservoir.

**Step 8** Follow the standard cleaning and sanitizing procedures.

**Removal of Parts for Cleaning/Sanitizing**

**⚠ Warning**

Disconnect electric power to the ice machine at the electric switch box and wear rubber gloves and safety goggles (or face shield) while handling cleaner or sanitizer.

**⚠ Caution**

Do not mix Cleaner and Sanitizer solutions together. It is a violation of Federal law to use these solutions in a manner inconsistent with their labeling.

1. Turn off the water supply to the ice machine at the water service valve.
2. Remove the components listed on the following pages for cleaning and sanitizing.
3. Soak the removed part(s) in a properly mixed solution of cleaner and water.

Solution Type	Water	Mixed With
Cleaner	1 gal. (4 L)	16 oz (500 ml) cleaner Part Number 000000084

4. Use a soft-bristle brush or sponge (NOT a wire brush) to carefully clean the parts.
5. Use the solution and a brush or sponge to clean all disassembled components and the inside of the bin.
6. Rinse all cleaned parts with clear water.
7. Mix a solution of sanitizer and water.

Solution Type	Water	Mixed With
Sanitizer	3 gal. (11 L)	2 oz (60 ml) sanitizer Part Number 94-0565-3

8. Soak the parts in the sanitizer/water solution for 10 minutes. Use the sanitizer/water solution and a sponge to sanitize all removed components and the inside of the bin. Do not rinse the sanitized parts.
9. Continue with step 11 of the cleaning/sanitizing procedure.

**ICE CHUTE REMOVAL**

RF-0300/RF-0650/RF-1200/RF-2300 ONLY

1. Place the toggle switch in the OFF position, turn off the water supply and disconnect electrical power to the ice machine.
2. Disconnect water supply.
3. Remove water reservoir cover.
4. Remove bin thermostat from ice chute.
5. Loosen bolts holding cross member.
6. Lift cross member and remove ice chute.

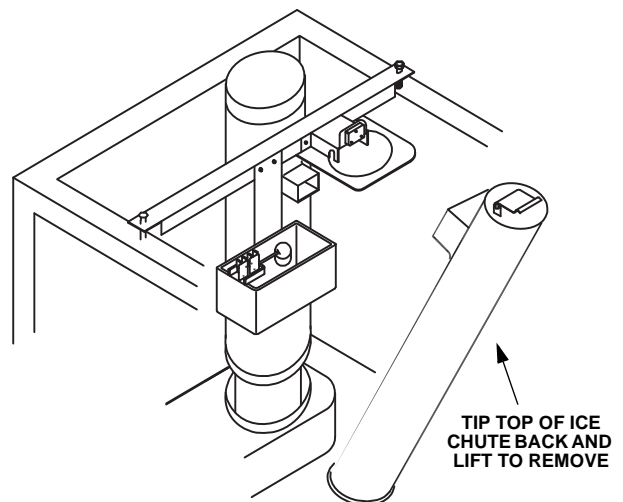
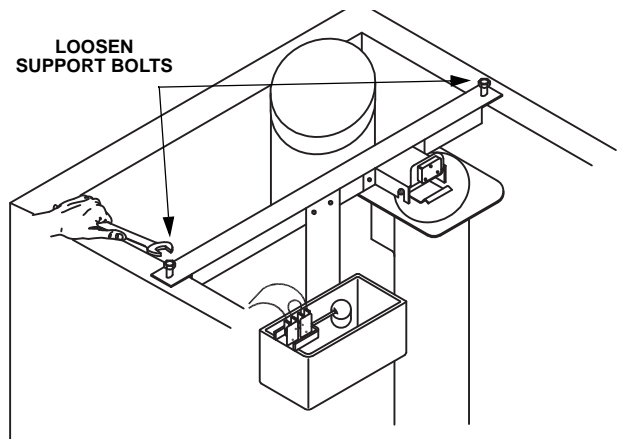

**ICE CHUTE SWITCH ACTUATOR REMOVAL**

RF-0300/RF-0650/RF-1200/RF-2300 Only

1. Pull to remove nylon end cap.
2. Slide pin to remove.
3. Remove both sections of the pressure switch bracket.

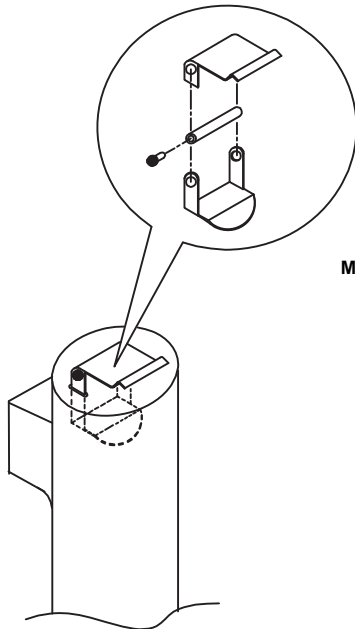

**INCORRECT REASSEMBLY  
CAN RESULT IN AN ICE  
MACHINE THAT WILL NOT RUN**

**Air-Cooled Condenser Cleaning**

**Warning**

Disconnect electric power to the ice machine and the remote condenser at the electric service switch before cleaning the condenser.

A dirty condenser restricts airflow, resulting in excessively high operating temperatures and reduced ice production. Clean the condenser at least every six months.

**Caution**

The condenser fins are sharp. Use care when cleaning them.

1. Clean the outside of the condenser with a soft brush or a vacuum with a brush attachment. Shine a flashlight through the condenser to check for dirt between the fins. If dirt remains, a method suitable to remove the contamination must be used to ensure air flow.
2. RF-0300/RF-0650/RF-1200/RF-2300 Only. Clean the washable filter with a mild soap and water solution.

**Arctic Pure Water Filter System**

Engineered specifically for Manitowoc ice machines. This water filter is an efficient, dependable, and affordable method of inhibiting scale formation, filtering sediment, and removing chlorine taste and odor.

**Manitowoc Cleaner and Sanitizer**

Manitowoc Ice Machine Nickel Safe Cleaner is available in convenient 16 oz. (473 ml) bottles. Manitowoc Ice Machine Sanitizer is available in 16 oz. (473 ml) and 1 gal (3.78 L) bottles.

Cleaner Part Number	Sanitizer Part Number
16 oz. 000000084	16 oz. 94-0565-3
	1 Gallon 94-0581-3

## Section 5

# Customer Support

### Before Calling For Service Checklist

If a problem arises during operation of your ice machine, follow the checklist below before calling for service.

Routine adjustments and maintenance procedures are not covered by the warranty.

Problem	Possible Cause	To Correct
Ice machine does not operate.	No electrical power to the ice machine.	Replace the fuse/reset the breaker/turn on main power switch/plug cord into receptacle.
	ON/OFF rocker switch set improperly.	Move rocker switch to the ON position.
	RF-0300/RF-0650/RF-1200/RF-2300 Only. 10 minute time delay has not expired.	Wait 10 minutes.
	Bin thermostat is open.	Adjust to a warmer setting; refer to Operation.
	RF-0244/RF-0266/RF-0388/RF0399 RF-0300/RF-0650 Only. Low temperature safety switch is open.	Adjust to colder setting; refer to Operation.
	RF-1200/RF-2300 Only. High Pressure Control is open.	Clean condenser, check fan motor, press manual reset (on left back corner post).
	Water reservoir is empty.	Open water service valve.
Gear Motor runs but compressor will not start.	RF-0244/RF-0266/RF-0388/RF0399 RF-0300/RF-0650 Only. Condenser dirty, compressor overload open.	Clean condenser, wait a minimum of 4 hours to allow internal compressor motor to cool.
	RF-0300/RF-0650/RF-1200/RF-2300 Only. 10 minute time delay has not expired.	Wait 10 minutes.
Ice quality is poor.	Poor incoming water quality.	Contact a qualified service company to test the quality of the incoming water and check filter.
	Water filtration is poor.	Replace filter.
	Incoming water temperature is above 90°F (32°C).	Correct water temperature. (Verify check/mixing valves in other equipment are working properly.) Connect the ice machine to a cold water supply.
	Water softener is working improperly (if applicable).	Repair the water softener.
Low ice capacity.	Water pressure is low.	Water pressure must remain between 20 and 80 psig.
	Incoming water temperature is above 90°F (32°C).	Correct water temperature. (Verify check/mixing valves in other equipment is working properly.)
	Water inlet valve stuck open or leaking.	Call for service.
Low ice capacity (Air-Cooled Models Only).	Objects stacked around ice machine, blocking airflow to condenser.	Remove items blocking airflow.
	High air temperature around ice machine.	Air temperature must not exceed 110°F (43°C).
	Inadequate clearance around the ice machine.	Provide adequate clearance.
	The condenser is dirty.	Clean the condenser.

## Commercial Ice Machine Warranty

### LIMITED WARRANTY FOR RF SERIES FLAKE ICE MACHINE

#### LIMITED WARRANTY

Manitowoc Ice a division of Manitowoc FSG Services, LLC, (“Company”) warrants that new RF Flake Ice Machines sold by Company shall be free of defects in material or workmanship under normal and proper use and maintenance as specified by the Company and upon proper installation and start-up in accordance with the instruction manual supplied.

#### WHAT IS COVERED

Parts for a period of three (3) years.

Labor for a period of two (2) years.

Compressor parts for five (5) years and labor for two (2) years.

The RF Flake Ice Machine warranty begins on the date of the original installation. This warranty shall not apply to any ice machine initially installed more than five (5) years from the serial number production date.

The obligation of the Company under this warranty is limited to the repair or replacement of parts, components, or assemblies that in the sole opinion of the Company are defective. This warranty is further limited to the cost of parts, components or assemblies and standard straight time labor charges (excluding the compressor warranty) at the servicing location.

Time and hourly rate schedules, as published from time to time by the Company, apply to all service procedures. Additional expenses including without limitation, travel time, overtime premium, material cost, accessing or removal of the RF Flake Ice Machine, or shipping are the responsibility of the purchaser, along with all maintenance, adjustments, cleaning, and ice purchases. Labor covered under this warranty must be performed by an approved Company contracted Service Representative or a refrigeration service agency as qualified and authorized by the Company’s local Distributor. The Company’s liability under this warranty shall in no event be greater than the actual purchase price paid by purchaser for the RF Flake Ice Machine.

#### EXCLUSIONS FROM COVERAGE

Repair or replacement of parts required because of misuse, improper care or storage, negligence, alteration, use of incompatible supplies or lack of specified maintenance shall be excluded.

Normal maintenance items.

Failures caused by improper or erratic voltages, adverse environmental or water conditions, improper drainage, interruption in electrical or water supply.

Improper or unauthorized repair.

Any RF Flake Ice Machine that has been installed and/or maintained inconsistent with the instructions provided by the Company.

Parts subject to damage beyond the control of Company, or to RF Flake Ice Machine’s which have been subject to accidents, damage in shipment, fire, floods, other hazards or acts of God that are beyond the control of the Company.

This Limited Warranty shall not apply if the RF Flake Ice Machine’s refrigeration system is modified with a condenser, heat reclaim device, or parts and assemblies other than those manufactured by the Company, unless the Company approves these modifications for specific locations in writing prior to the commencement of such modification.

#### LIMITATIONS OF LIABILITY

The preceding paragraphs set forth the exclusive remedy for all claims based on failure of, or defect in, RF Flake Ice Machines sold hereunder, whether the failure or defect arises before or during the warranty period, and whether a claim, however instituted, is based on contract, indemnity, warranty, tort (including negligence), strict liability, implied by statute, common-law or otherwise, and Company and agents shall not be liable for any claims for personal injuries or consequential damages or loss, howsoever caused. Upon the expiration of the warranty period, all such liability shall terminate. THE FOREGOING WARRANTIES ARE EXCLUSIVE AND IN LIEU OF ALL OTHER WARRANTIES, WHETHER WRITTEN, ORAL, IMPLIED OR STATUTORY NO IMPLIED WARRANTY OF MERCHANTABILITY OR FITNESS FOR PARTICULAR PURPOSE SHALL APPLY, COMPANY DOES NOT WARRANT ANY PRODUCTS OR SERVICES OF OTHERS.

#### REMEDIES

The liability of Company for breach of any warranty obligation hereunder is limited to: (i) the repair or replacement of the RF Flake Ice Machine on which the liability is based, or with respect to services, re-performance of the services; or (ii) at Company’s option, the refund of the amount paid for said equipment or services. Any breach by Company with respect to any item or unit of equipment or services shall be deemed a breach with respect to that item or unit or service only.

#### WARRANTY CLAIM PROCEDURE

Customer shall be responsible to:

Complete and return warranty registration card or register on line within five (5) days from the installation date.

Complete the following and retain for your records:

Distributor/Dealer

Model Number and Serial Number

Installation Date

All warranty service must be performed by an approved Manitowoc contracted or authorized Service Representative. To schedule a service appointment contact your local Manitowoc Service Representative or visit us at [www.manitowocice.com](http://www.manitowocice.com) to find a Service Representative near you.

#### GOVERNING LAW

This Limited Warranty shall be governed by the laws of the state of Wisconsin, USA, excluding their conflicts of law principles. The United Nations Convention on Contracts for the International Sale of Goods is hereby excluded in its entirety from application to this Limited Warranty.

#### MANITOWOC ICE

2110 South 26th Street

P.O. Box 1720

Manitowoc, WI 54221-1720

Web site: [www.manitowocice.com](http://www.manitowocice.com)

## Residential Ice Machine Limited Warranty

### WHAT DOES THIS LIMITED WARRANTY COVER?

Subject to the exclusions and limitations below, Manitowoc Ice ("Manitowoc") warrants to the original consumer that any new ice machine manufactured by Manitowoc (the "Product") shall be free of defects in material or workmanship for the warranty period outlined below under normal use and maintenance, and upon proper installation and start-up in accordance with the instruction manual supplied with the Product.

### HOW LONG DOES THIS LIMITED WARRANTY LAST?

<u>Product Covered</u>	<u>Warranty Period</u>
Ice Machine	Twelve (12) months from the sale date

### WHO IS COVERED BY THIS LIMITED WARRANTY?

This limited warranty only applies to the original consumer of the Product and is not transferable.

### WHAT ARE MANITOWOC ICE'S OBLIGATIONS UNDER THIS LIMITED WARRANTY?

If a defect arises and Manitowoc receives a valid warranty claim prior to the expiration of the warranty period, Manitowoc shall, at its option: (1) repair the Product at Manitowoc's cost, including standard straight time labor charges, (2) replace the Product with one that is new or at least as functionally equivalent as the original, or (3) refund the purchase price for the Product. Replacement parts are warranted for 90 days or the balance of the original warranty period, whichever is longer. The foregoing constitutes Manitowoc's sole obligation and the consumer's exclusive remedy for any breach of this limited warranty. Manitowoc's liability under this limited warranty is limited to the purchase price of Product. Additional expenses including, without limitation, service travel time, overtime or premium labor charges, accessing or removing the Product, or shipping are the responsibility of the consumer.

### HOW TO OBTAIN WARRANTY SERVICE

To obtain warranty service or information regarding your Product, please contact us at:

MANITOWOC ICE

2110 So. 26th St.

P.O. Box 1720,

Manitowoc, WI 54221-1720

Telephone: 920-682-0161 Fax: 920-683-7585

[www.manitowocice.com](http://www.manitowocice.com)

### WHAT IS NOT COVERED?

This limited warranty does not cover, and you are solely responsible for the costs of: (1) periodic or routine maintenance, (2) repair or replacement of the Product or parts due to normal wear and tear, (3) defects or damage to the Product or parts resulting from misuse, abuse, neglect, or accidents, (4) defects or damage to the Product or parts resulting from improper or unauthorized alterations, modifications, or changes; and (5) defects or damage to any Product that has not been installed and/or maintained in accordance with the instruction manual or technical instructions provided by Manitowoc. To the extent that warranty exclusions are not permitted under some state laws, these exclusions may not apply to you.

Except As Stated In The Following Sentence, This Limited Warranty Is The Sole And Exclusive Warranty Of Manitowoc With Regard To The Product. All Implied Warranties Are Strictly Limited To The Duration Of The Limited Warranty Applicable To The Products As Stated Above, Including But Not Limited To, Any Warranty Of Merchantability Or Of Fitness For A Particular Purpose.

Some states do not allow limitations on how long an implied warranty lasts, so the above limitation may not apply to you.

In No Event Shall Manitowoc Or Any Of Its Affiliates Be Liable To The Consumer Or Any Other Person For Any Incidental, Consequential Or Special Damages Of Any Kind (Including, Without Limitation, Loss Profits, Revenue Or Business) Arising From Or In Any Manner Connected With The Product, Any Breach Of This Limited Warranty, Or Any Other Cause Whatsoever, Whether Based On Contract, Tort Or Any Other Theory Of Liability.

Some states do not allow the exclusion or limitation of incidental or consequential damages, so the above limitation or exclusion may not apply to you.

### HOW STATE LAW APPLIES

This limited warranty gives you specific legal rights, and you may also have rights that vary from state to state or from one jurisdiction to another.

### REGISTRATION CARD

To secure prompt and continuing warranty service, this warranty registration card must be completed and sent to Manitowoc within thirty (30) days from the sale date. Complete the registration card and send it to Manitowoc.

### C Model Bin Limited Warranty

#### LIMITED WARRANTY FOR C200, C350 ICE STORAGE BIN

##### LIMITED WARRANTY

Manitowoc Ice a division of Manitowoc FSG Services, LLC, (“Company”) warrants that new C200, C350 Ice Storage Bins sold by Company shall be free of defects in material or workmanship under normal and proper use and maintenance as specified by the Company and upon proper installation and start-up in accordance with the instruction manual supplied.

##### WHAT IS COVERED

- Parts for a period of two (2) years. The C200, C350 Ice Storage Bin warranty begins on the date of the original installation. This warranty shall not apply to any ice machine initially installed more than five (5) years from the serial number production date.

The obligation of the Company under this warranty is limited to the replacement of parts, components, or assemblies that in the sole opinion of the Company are defective. This warranty is further limited to the cost of parts, components or assemblies at the servicing location.

Additional expenses including without limitation labor charges, travel time, overtime premium, material cost, accessing or removal of the C200, C350 Ice Storage Bin, or shipping are the responsibility of the purchaser, along with all maintenance, adjustments, cleaning, and ice purchases. The Company’s liability under this warranty shall in no event be greater than the actual purchase price paid by purchaser for the C200, C350 Ice Storage Bin.

##### EXCLUSIONS FROM COVERAGE

- Replacement of parts required because of misuse, improper care or storage, negligence, alteration, use of incompatible supplies or lack of specified maintenance shall be excluded.
- Normal maintenance items.
- Failures caused by improper or adverse environmental or water conditions or improper drainage.
- Improper or unauthorized repair.
- Any C200, C350 Ice Storage Bin that has been installed and/or maintained inconsistent with the instructions provided by the Company.
- Parts subject to damage beyond the control of Company, or to C200, C350 Ice Storage Bins which have been subject to accidents, damage in shipment, fire, floods, other hazards or acts of God that are beyond the control of the Company.

##### LIMITATIONS OF LIABILITY

The preceding paragraphs set forth the exclusive remedy for all claims based on failure of, or defect in, C200, C350 Ice Storage Bins sold hereunder, whether the failure or defect arises before or during the warranty period, and whether a claim, however instituted, is based on contract, indemnity, warranty, tort (including negligence), strict liability, implied by statute, common-law or otherwise, and Company and agents shall not be liable for any claims for personal injuries or consequential damages or loss, howsoever caused. Upon the expiration of the warranty period, all such liability shall terminate. THE FOREGOING WARRANTIES ARE EXCLUSIVE AND IN LIEU OF ALL OTHER WARRANTIES, WHETHER WRITTEN, ORAL, IMPLIED OR STATUTORY. NO IMPLIED WARRANTY OF MERCHANTABILITY OR FITNESS FOR PARTICULAR PURPOSE SHALL APPLY, COMPANY DOES NOT WARRANT ANY PRODUCTS OR SERVICES OF OTHERS.

##### REMEDIES

The liability of the Company for breach of any warranty obligation hereunder is limited to: (i) the replacement of the C200, C350 Ice Storage Bin, parts, and components on which the liability is based, or (ii) at Company’s option, the refund of the amount paid for said equipment or services. Any breach by Company with respect to any item or unit of equipment shall be deemed a breach with respect to that item or unit.

##### WARRANTY CLAIM PROCEDURE

Customer shall be responsible to:

- Complete and return warranty registration card or register on line within five (5) days from the installation date. Complete the following and retain for your records:  
Distributor/Dealer  
Model Number and Serial Number  
Installation Date
- All warranty service must be preformed by an approved Manitowoc contracted or authorized Service Representative. To schedule a service appointment contact your local Manitowoc Service Representative or visit us at [www.manitowocice.com](http://www.manitowocice.com) to find a Service Representative near you.

##### GOVERNING LAW

This Limited Warranty shall be governed by the laws of the state of Wisconsin, USA, excluding their conflicts of law principles. The United Nations Convention on Contracts for the International Sale of Goods is hereby excluded in its entirety from application to this Limited Warranty.

##### COMPLETE AND RETAIN FOR YOUR RECORD:

Distributor/Dealer \_\_\_\_\_  
 Model Number \_\_\_\_\_  
 Serial Number \_\_\_\_\_  
 Installation Date \_\_\_\_\_

MANITOWOC ICE  
 2110 South 26th Street  
 P.O. Box 1720  
 Manitowoc, WI 54221-1720  
 Web site: [www.manitowocice.com](http://www.manitowocice.com)



© 2009 Manitowoc

Continuing product improvements may necessitate change of specifications without notice.

Part Number 000005653 10/09



Manitowoc Foodservice  
2110 South 26th Street, P.O. Box 1720  
Manitowoc, WI 54221-1720, USA  
Ph: 920-682-0161 Fax: 920-683-7589  
Visit us online at: [www.manitowocice.com](http://www.manitowocice.com)

