

**WARING**  
**COMMERCIAL**

**MX1050XT**

64 oz. BPA-Free copolyester container

**MX1050XTP**

32-48 oz. BPA-Free copolyester container

**MX1050XTS**

64 oz. stainless steel container

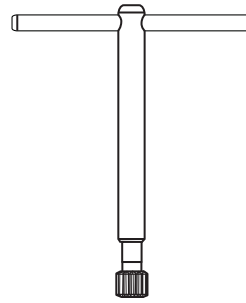

**503351**  
MX Coupling Wrench  
(optional)



**013304**  
NSF Seal

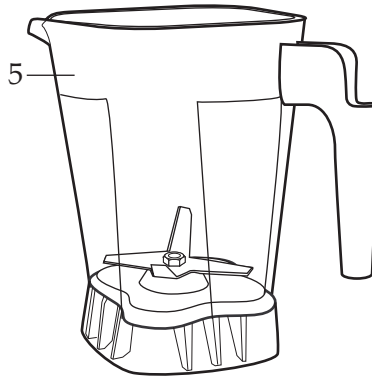
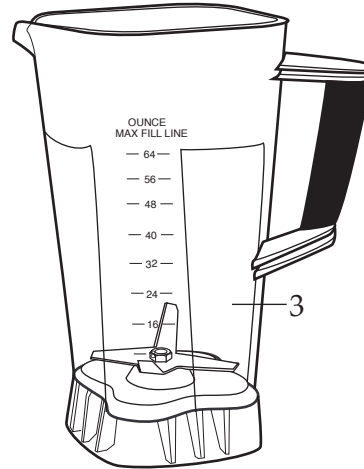
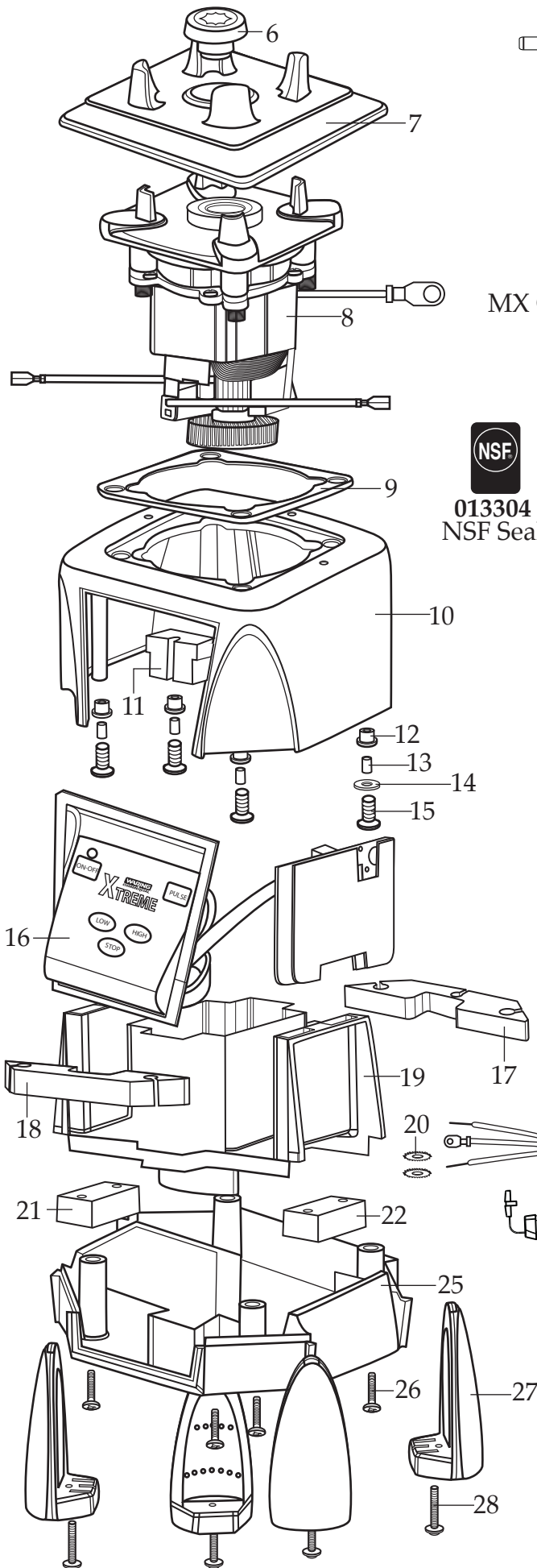

**Unit Information**

Limited 3 Year Motor Warranty  
Two Year Parts & Labor

60Hz – 13 Amps  
Height 19" – Weight 15 lbs.  
3 HP Motor  
30,000+ RPM's  
One Piece Dishwasher Safe  
Removable Jar Pad

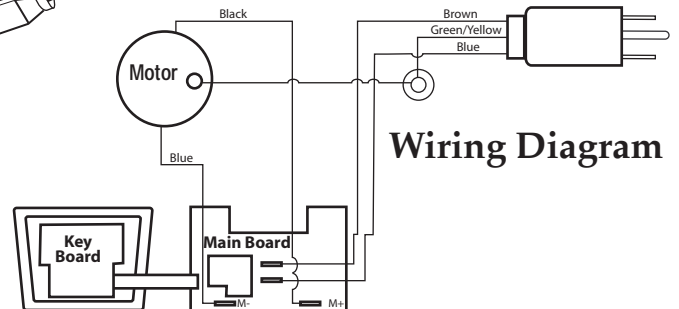
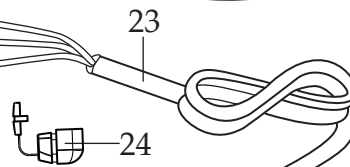

**Wiring Diagram**

Catalog	Model
MX1050XT	MX1050XT11
MX1050XTP	MX1050XT21
MX1050XTS	MX1050XT31



Illustration #	Part #	Description
1	026425-E	Jar Lid Cover
2	026424	Jar Lid
3	503347	Jar with Blending Assy. /64 oz. Eastman
4	503346	Jar with Blending Assy. /64 oz. stainless steel
5	503348	Jar with Blending Assy. /32-48 oz. Eastman
6	028538	Drive Clutch
7	026442	Jar Pad
8	028100	Motor
9	026437	Dampening Plate Gasket
10	028032-09	Top Housing /black
11	028541	Motor Foam 2 Req.'d
12	026439	Dampening Plate Bushing 4 Req.'d
13	026453	Dampening Plate Sleeve 4 Req.'d
14	026459	Washer
15	028929	Screw 4 Req.'d
	026459	Washer 4 Req.'d <i>(older units)</i>
	026455	Screw 4 Req.'d <i>(older units)</i>
16	029809	Control Panel /soft start
	028389	Control Panel <i>(2nd generation &amp; older units)</i>
17	028248	Housing Foam Baffle /rear
18	028249	Housing Foam Baffle /front
19	028240	Motor Housing
20	002943	Washer 2 Req.'d
21	028247	Bottom Housing Foam Baffle
22	028542	Foam Baffle
23	026925	Cord Set
24	007556	Strain Relief
25	028241-09-x	Bottom Housing /black
26	012505	Screw 4 Req.'d
27	026430	Corner Post 4 Req.'d
28	028928	Screw 4 Req.'d
	026459	Washer 4 Req.'d <i>(older units)</i>
	012505	Screw 4 Req.'d <i>(older units)</i>

Catalog	Model
MX1050XT	MX1050XT11
MX1050XTP	MX1050XT21
MX1050XTS	MX1050XT31

**Waring Factory Service Center**  
 314 Ella T. Grasso Ave.  
 Torrington, CT 06790  
 Tele. 1-800-269-6640  
 Fax 860-496-9017  
 www.waringproducts.com

Illustration #	Part #	Description
29	503345	Blade Assy.
30	024271	O Ring
31	024268	Nut Gasket
32	029631	Bearing Holder Nut
33	026423-E	64 oz. Eastman Container
34	029003-E	32-48 oz. Eastman Container
35	026798	Support Washer
36	026648	64 oz. Containter / stainless steel
37	026649	Container Support
38	026797	Bearing Holder Gasket
39	026796	Bearing Holder Washer
40	026795	SS Jar Bearing Holder Nut

**Notes for 503347 & 503348 :**

Torque 100-125 in/lbs

Sealant all around the threads, fill in flats.  
 Dow Corning Sealant RTV 733

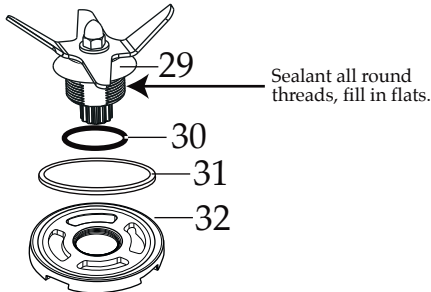

**031060**  
Blending Assy. Kit

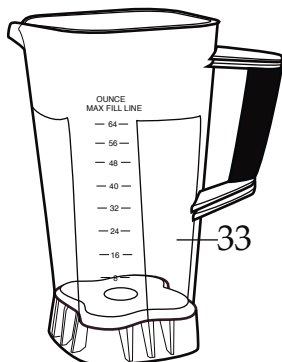
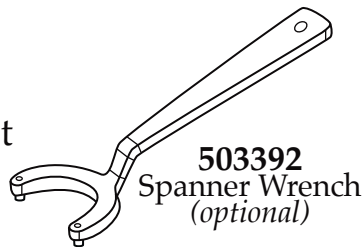

**503347 and 503348 - Eastman Containers**

**Notes for 503346 :**

Torque 100-125 in/lbs

Sealant applied all around indicated areas.  
 Dow Corning Sealant RTV 733

Lubricant applied to O Ring  
 Dow Corning 200 (R) Fluid

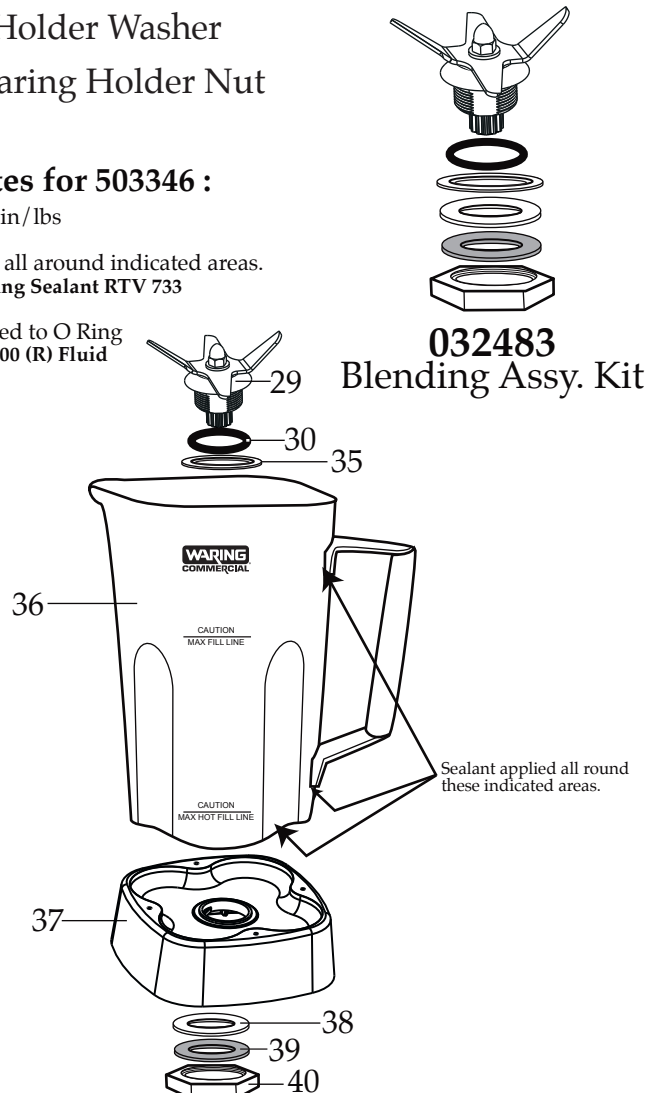

**032483**  
Blending Assy. Kit

**503346 - Stainless Steel Container**