

Operator's Manual

DROP-IN FROST TOP



Item	Description	HP	Voltage	Amps	Plug
36419	Two-pan	1/4 hp	120V	4.9	5-15P
36420	Three-pan	1/3 hp	120V	5.9	5-15P
36424	Four-pan	1/3 hp	120V	5.9	5-15P
36426	Five-pan	1/2 hp	120V	12.9	5-20P
36428	Six-pan	1/2 hp	120V	12.9	5-20P

Thank you for purchasing this Vollrath equipment. Before operating the equipment, read and familiarize yourself with the following operating and safety instructions. SAVE THESE INSTRUCTIONS FOR FUTURE REFERENCE. Save the original box and packaging. Use this packaging to ship the equipment if repairs are needed.

SAFETY PRECAUTIONS

To ensure safe operation, read the following statements and understand their meaning. Please read carefully.

WARNING

Warning is used to indicate the presence of a hazard that *can* cause severe personal injury, death, or substantial property damage if the warning is ignored.

CAUTION

Caution is used to indicate the presence of a hazard that *will or can* cause *minor* personal injury or property damage if the caution is ignored.

NOTE

Note is used to notify people of installation, operation, or maintenance information that is important but not hazard-related.

For Your Safety!

These precautions should be followed at all times. Failure to follow these precautions could result in injury to yourself and others.

To reduce risk of injury or damage to the equipment:

- Use only grounded electrical outlets matching the nameplate rated voltage.
- Have the equipment installed by qualified personnel.
- When enclosed, unit must have required ventilation.
- Do not use an extension cord with this equipment. Do not plug this equipment into a power strip or multi-outlet power cord.
- Unit should only be used in a flat, level position.
- Do not spray controls or outside of equipment with liquids or cleaning agents.
- Do not clean the equipment with steel wool.
- Keep equipment and power cord away from open flames, electric burners or excessive heat.
- Do not operate unattended.
- Do not operate equipment in public areas and/or around children.
- Do not operate if equipment has been damaged or is malfunctioning in any way.

FUNCTION AND PURPOSE

This unit is intended to hold containers of pre-chilled cold food product at the proper serving temperature for service. This unit is not designed or intended to cool hot food or cool any item not properly chilled before being placed on the unit. Refrigerated cold pans are best used for holding periods up to four hours. For best performance, stainless steel containers are recommended.

Before using this equipment it must be cleaned and dried thoroughly. This equipment is not intended for household, industrial or laboratory use.

UNPACKING THE EQUIPMENT AND INITIAL SETUP

When no longer needed, dispose of all packaging and materials in an environmentally responsible manner.

1. Remove all packing material and tape, as well as any protective plastic from the equipment.
2. Clean any glue residue left over from the plastic or tape.

NOTE

The refrigerated models must be provided with adequate ventilation. The minimum requirement is the equivalent of 80 square inches (516 cm²) of air intake and air exhaust.

Have the unit installed only by qualified service personnel. The cutout opening in counter must be in accordance with the chart below. All openings must be within 1/8" of the stated dimension and have a 7/8" radius at the corners. Use the watertight gasket provided to seal between counter and unit to prevent water from leaking into control areas.

NOTE

All cutout openings must be within 1/8" of listed opening sizes and have a corner radius of 7/8". Cutout dimensions given in inches and (cm).

3. Refer to the *Cutout Dimension Chart* in this Manual for cutout dimensions.
4. Place the watertight gasket over the cut-out and center the well.
5. Set the equipment into place.

FEATURES AND CONTROLS

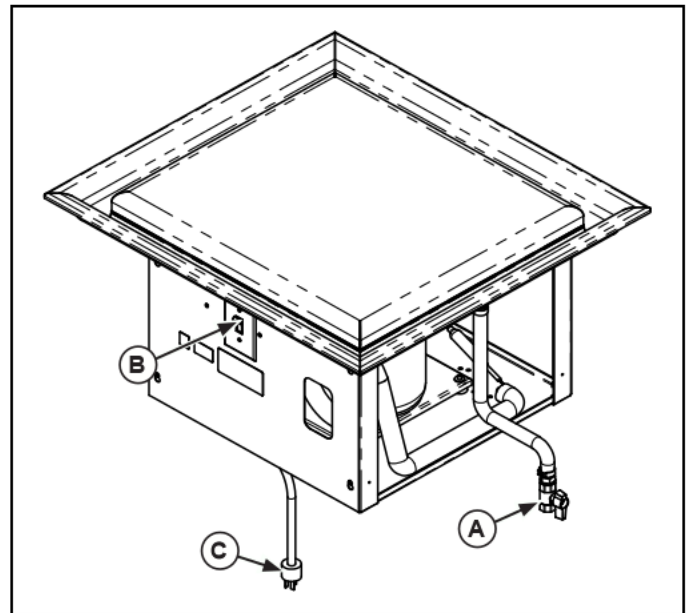



Figure 1. Features and Controls.

- (A) DRAIN VALVE. Used to empty water from the well(s).
- (B) ON/OFF SWITCH (some models). Switches the equipment power ON or OFF.
- (C) ELECTRICAL PLUG. Grounded electrical plug connects to the grounded power source.



OPERATION

	WARNING
	<p>Electrical Shock Hazard. Keep water and other liquids from entering the inside of the unit. Liquid inside the unit could cause an electrical shock. Do not damaged power cord.</p>
<p>Do not over fill wells, pans or trays. Liquid could contact the electrical components and cause a short circuit or an electrical shock. Unplug unit before performing service, draining or removing spillage pans and trays. Do not spray water or cleaning products. Do not use a power cord that has been modified or damaged.</p>	

1. Check the drain valve (A) to verify it is in the CLOSED position to prevent water from draining out. See Figure 1. The valve is in the CLOSED position when the handle of the valve forms a "T" with the body of the valve.
2. Plug the equipment into a properly grounded electrical supply matching the nameplate rating. Damage to the equipment can occur if incorrect power is supplied to equipment.
3. Turn the power switch (B) to the "ON" position. This unit does not have an adjustable temperature setting. Allow the unit to run for approximately 30 minutes. For the best performance when using ice with this unit, allow unit to run for approximately 2 hours before adding ice. This will help the ice remain solid.
4. Place containers of properly chilled food onto the pre-chilled unit.
5. Regularly check the food temperature.

NOTE:

Monitor food temperature closely for food safety. The United States Public Health Service recommends that hot food be held at a maximum of 41 °F (5 °C) to help prevent bacteria growth.

6. When finished using the unit turn the power switch (B) to the "OFF" position. Remove the food containers.
7. Place a suitable container directly under the drain valve (A) Open the drain valve and drain the water. The valve is in the OPEN position when the handle of the valve is aligned with the body of the valve.
8. Close the drain valve (A). Rotate the valve to the CLOSED position, when the handle of the valve forms a "T" with the body of the valve.

TROUBLESHOOTING CHART

Problem	It might be caused by	Course of Action
Unit does not get to correct temperature.	Unit is not plugged in.	Plug unit in.
	Compressor defective.	Have the compressor replaced.

SERVICE AND REPAIR

There are no user serviceable parts within this appliance. To avoid serious injury or damage, never attempt to repair the equipment or replace a damaged power cord yourself. Do not send equipment directly to the Vollrath Company. Please contact the qualified professional repair service listed below.

VOLLRATH Technical Service • 1-800-628-0832

CLEANING

To maintain the appearance and increase the service life, clean your equipment daily.

NOTE:

Do not use caustic cleaning chemicals, steel wool or commercial lime removal products to clean the equipment. Thoroughly rinse equipment with water after cleaning.

	WARNING
	<p>Electrical Shock Hazard. Keep water and other liquids from entering the inside of the unit. Liquid inside the unit could cause an electrical shock. Do not damaged power cord.</p>
<p>Do not over fill wells, pans or trays. Liquid could contact the electrical components and cause a short circuit or an electrical shock. Unplug unit before performing service, draining or removing spillage pans and trays. Do not spray water or cleaning products. Do not use a power cord that has been modified or damaged.</p>	

9. When finished using the unit turn the power switch (B) to the "OFF" position. Remove the food containers.
10. Open the drain valve (A) and drain the water. The valve is in the OPEN position when the handle of the valve is aligned with the body of the valve.
11. Using a damp cloth, sponge dipped in soapy water to clean the inside of the well and the outside of the equipment.
12. Close the drain valve (A). Rotate the valve to the CLOSED position, when the handle of the valve forms a "T" with the body of the valve.

CUTOUT DIMENSIONS CHART DROP-INS FROST TOP

CUTOUT dimensions given in inches and (cm).

Item	Cutout Dimensions
36419	25-1/4 x 27-1/2 (64.1 x 69.8)
36420	25-1/4 x 40-3/4 (64.1 x 103.5)
36424	25-1/4 x 54 (64.1 x 137.1)
36426	25-1/4 x 67-1/4 (64.1 x 170.8)
36428	25-1/4 x 80-1/2 (64.1 x 204.4)

WARRANTY STATEMENT FOR THE VOLLRATH CO. L.L.C.

The Vollrath Company LLC warrants the products it manufactures and distributes against defects in materials and workmanship for a period of one year, except as specifically provided below. The warranty runs 12 months from the date of original installation. (End user receipt)

1. Refrigeration compressors – The warranty period is 5 years.
2. Replacement parts – The warranty period is 90 days.
3. Fry pans and coated cookware – The warranty period is 90 days
4. EverTite™ Riveting System – The warranty covers loose rivets only, forever.
5. Cayenne® Heat Strips – The warranty period is 1 year plus an additional 1 year period on heating element parts only.
6. Ultra and Professional Induction Ranges – The warranty period is 2 years.
7. Mirage and Commercial Induction ranges - The warranty period is 1 year.
8. ServeWell® Induction Workstations – The warranty period is one year on the workstation table and 2 years on induction hobs.
9. Slicers – The warranty period is 10 years on gears and 5 years on belts.
10. Mixers – The warranty period is 2 years.
11. Extended warranties are available at the time of sale.
12. Vollrath – Redco products – The warranty period is 2 years.
13. Optio / Arkadia product lines – The warranty period is 90 days.
14. All non-stick products (i.e. fry pans and surfaces) are 90 days for the non stick surfaces.

All products in the Jacob's Pride® collection, including the following, have a lifetime warranty:

- NSF Certified One-Piece Dishes
- NSF Certified Spoodle® Utensils
- NSF Certified Heavy-Duty Spoons with Ergonomic Handle
- NSF Certified Heavy-Duty Basting Spoons
- Heavy duty Turners with Ergonomic handle
- One-Piece Tongs*
- Heavy-Duty One-Piece Ladles*
- Nylon Handle Whips
- One-Piece Skimmers
- Tribute®, Intrigue®, and Classic Select® Cookware*

*Jacob's Pride® warranty does not cover Kool-Touch®, non stick coatings and silicone handles.

Items sold having no warranty:

- Meat Grinder Knives
- Light Bulbs in Convection Ovens and Hot Food Merchandiser
- Oven Door Seals
- Oven Door Glass
- Hot Food Merchandisers / Display Case Glass
- Calibration and set up of gas equipment
- Slicer / Dicer blades (table top food prep) – Redco and Vollrath

THIS WARRANTY IS IN LIEU OF ANY OTHER WARRANTIES, EXPRESS OR IMPLIED, INCLUDING ANY IMPLIED WARRANTY OF MERCHANTABILITY OR FITNESS FOR A PARTICULAR PURPOSE

As The Vollrath Company LLC's only responsibility and the purchaser's only remedy, for any breach of warranty, The Vollrath Company LLC will repair or, at its option, replace the defective product or part without charge, except as otherwise provided below:

- For refrigeration compressors and the second year of the warranty on Cayenne® Heat Strips and mixers, The Vollrath Company LLC will provide the repaired or replacement part only; and the buyer will be responsible for all labor charges incurred in performing the repair or replacement.
- To obtain warranty service, the buyer will be responsible to return to The Vollrath Company LLC any product (other than gas equipment that is permanently installed) weighing less than 110 lbs. or located outside of a 50-mile radius of a certified technician designated by The Vollrath Company LLC to perform warranty repairs. If a Vollrath Technician cannot be contacted check the website for service contact points. (Please refer to the Product Catalogue for weights and sizes of product)
- No remedy will be available for products that have been damaged by accident, carelessness, improper installation, lack of proper setup or supervision when required, neglect, improper use, installation or operation contrary to installation and operating instructions or other causes not arising out of defects in materials or workmanship. At the buyer's request, The Vollrath Company LLC will repair and or replace such products at a reasonable cost.
- No remedy will be available for slicers where blade has not been sharpened (Refer to owner's manual for sharpening instructions)
- No remedy will be available for mixers damaged by changing gears while unit is running or overloading, in either case as determined by a Vollrath Certified Technician
- Warranty work must be authorized in advance by The Vollrath Company LLC. See the operating and safety instructions for each product for detailed warranty claim procedures.
- No remedy will be available for product returned and found to be acceptable to the product specification.
- No remedy will be available under any warranty not registered as required below.

LIMITATION OF LIABILITY:

THE VOLLRATH COMPANY LLC SHALL HAVE NO LIABILITY FOR INCIDENTAL OR CONSEQUENTIAL DAMAGES OF ANY KIND, WHETHER BASED UPON NEGLIGENCE OR OTHER TORT, BREACH OF WARRANTY, OR ANY OTHER THEORY.



WARRANTY PROCEDURE

On all warranty calls, the following process and information is required:

- All warranty claims will start with a call to Vollrath Technical Service support line.(800-354-1970).
- A technical support professional will work to diagnose the issues, and provide the details for the service solution.
- Name and phone number of person calling
- Business name, street address, city, state and zip
- Model and serial number
- Date of purchase and proof of purchase (Receipt)
- Name of dealer where unit was purchased

NOTE: Vollrath will not accept products sent without the proper procedure being followed.

Important:

TO MAKE A CLAIM FOR ANY REMEDY UNDER THIS WARRANTY, YOU MUST REGISTER YOUR WARRANTY.

REGISTER TODAY

ONLINE: Register your warranty on-line now at www.Vollrathco.com

NO WEB ACCESS: If you do not have access to the web, kindly register by completing the warranty registration form and faxing it to The Vollrath Co. LLC office in the country of purchase.

WARRANTY REGISTRATION				
BUSINESS NAME				
KEY CONTACT NAME			EMAIL	
STREET ADDRESS				
CITY		STATE	ZIP CODE	
COUNTRY		PHONE	FAX	
MODEL			ITEM NUMBER	
SERIAL NUMBER	<input type="text"/>	<input type="text"/>	-	<input type="text"/>
OPERATION TYPE				
R Limited Service Restaurant	R Full Service Restaurant	R Bars and Taverns	R Supermarket	
R Convenience Store	R Recreation	R Hotel/Lodging	R Airlines	
R Business/Industry	R Primary/Secondary School	R Colleges/University	R Hospitals	
R Long-Term Care	R Senior Living	R Military	R Corrections	
REASON FOR SELECTING OUR PRODUCT				
R Appearance	R Full Service Restaurant	R Availability	R Sellers Recommendation	
R Ease of Operation	R Versatility of Use	R Price	R Brand	
WOULD YOU LIKE TO RECEIVE OUR FULL-LINE CATALOG AND REMAIN ON OUR MAILING LIST?			R Yes	R No

ENGLISH



www.vollrathco.com

The Vollrath Company, L.L.C.
1236 North 18th Street
Sheboygan, WI 53081-3201
U.S.A.

Main Tel: 800.628.0830
Fax: 800.752.5620

Technical Services: 800.628.0832
Service Fax: 920.459.5462

Canada Service: 800.695.8560

© 2011 The Vollrath Company, L.L.C.

