

StarMax[®]

DEEP FAT FRYER

MODEL
530TD & 530TED SERIES

Installation and Operation Instructions

2M-Z6600 Rev.D 2/3/2011



530TD



SAFETY SYMBOL



These symbols are intended to alert the user to the presence of important operating and maintenance instructions in the manual accompanying the appliance.

RETAIN THIS MANUAL FOR FUTURE REFERENCE NOTICE

Using any part other than genuine Star factory supplied parts relieves the manufacturer of all liability.

Star reserves the right to change specifications and product design without notice. Such revisions do not entitle the buyer to corresponding changes, improvements, additions or replacements for previously purchased equipment.

Due to periodic changes in designs, methods, procedures, policies and regulations, the specifications contained in this sheet are subject to change without notice. While Star International Holdings Inc., Company exercises good faith efforts to provide information that is accurate, we are not responsible for errors or omissions in information provided or conclusions reached as a result of using the specifications. By using the information provided, the user assumes all risks in connection with such use.

MAINTENANCE AND REPAIRS

Contact your local authorized service agent for service or required maintenance.

Please record the model number, serial number, voltage and purchase date in the area below and have it ready when you call to ensure a faster service.

Model No. _____

Serial No. _____

Voltage _____

Purchase Date _____

Authorized Service Agent Listing

Reference the listing provided with the unit

OR

for an updated listing go to:

Website: www.star-mfg.com
E-mail Service@star-mfg.com
Telephone: (800) 807-9054 Local (314) 781-2777

Service Help Desk

Business Hours: 8:00 am to 4:30 p.m. Central Standard Time

Telephone: (800) 264-7827 Local (314) 781-2777

Fax: (800) 396-2677 Local (314) 781-2714

E-mail Parts@star-mfg.com
Service@star-mfg.com
Warranty@star-mfg.com

Website: www.star-mfg.com

Mailing Address: Star International Holdings Inc., Company
10 Sunnen Drive
St. Louis, MO 63143
U.S.A

SPECIFICATIONS:

530TD

Type: TWIN POT ELECTRIC FRYERS

208V, 8,638 watts, 41.5 amp

240V, 11,500 watts, 47.5 amp

Approximate weight: installed - 69 Lb s (31.3 kg), shipping - 81 Lbs (36.7 kg)

Dimensions: 24" - Width, 24" - Depth, 16 3/4" - Height (61 cm-width, 61 cm-depth, 42.5 cm-weight)

530TED

Type: TWIN POT ELECTRIC FRYERS

208V, 6,910 watts, 33.2 amp

240V, 9,200 watts, 38.3 amp

Approximate weight: installed - 69 Lb s (31.3 kg), shipping - 81 Lbs (36.7 kg)

Dimensions: 24" - Width, 24" - Depth, 16 3/4" - Height (61 cm-width, 61 cm-depth, 42.5 cm-weight)



GENERAL INSTALLATION DATA

This equipment is designed and sold for commercial use only by personnel trained and experienced in its operation and is not sold for consumer use in and around the home nor for use directly by the general public in food service locations.

Before using your new equipment, read and understand all the instructions & labels associated with the unit prior to putting it into operation. Make sure all people associated with its use understand the units operation & safety before they use the unit.

All shipping containers should be checked for freight damage both visible and concealed. This unit has been tested and carefully packaged to insure delivery of your unit in perfect condition. If equipment is received in damaged condition, either apparent or concealed, a claim must be made with the delivering carrier.

Concealed damage or loss - if damage or loss is not apparent until after equipment is unpacked, a request for inspection of concealed damage must be made with carrier within 15 days. Be certain to retain all contents plus external and internal packaging materials for inspection. The carrier will make an inspection and will supply necessary claim forms.

WARNING: Improper installation, adjustment, alteration, service or maintenance can cause property damage, injury or death. Read the installation, operating and maintenance instructions thoroughly before installing or servicing the equipment.

This fryer is equipped for the voltage and wattage indicated on the nameplate mounted on the lower right corner of the element housing. It is designed for use on alternating current (AC) only. It is intended for use by properly trained personnel only.



DO NOT CONNECT TO DIRECT CURRENT (DC)

The installation of the appliance should conform to the:

NATIONAL ELECTRIC CODE AND ALL LOCAL ELECTRIC CODES AND ORDINANCES AND THE LOCAL ELECTRIC COMPANY RULES AND REGULATIONS

For your protection we recommend that a qualified electrician install this appliance. He should be familiar with electrical installations and all electrical codes. Proper connections and power supply are essential for efficient performance. The external wiring should be in conduit or an approved type of flexible cable suitable for operation at 90° C (194° F) and of a proper size to carry the load. The supply circuit should be properly fused and equipped with a means of disconnection, as required by local electrical code. **THE BODY OF THE APPLIANCE SHOULD BE GROUNDED - DO NOT GROUND TO A GAS SUPPLY LINE.** Four legs are provided and should be installed for ease of cleaning. Level unit by adjusting the (4) feet which have an adjustment of 1-3/8" (34.92 mm) for accurate leveling and perfect line-up with other units.

POWER SUPPLY

Models 530TD and 530TED are wired at the factory for operation on a single phase power supply. For specific wiring, check the wiring diagram.

OPERATING INSTRUCTIONS



PLACE THE LAMINATED WARNING SIGN SUPPLIED WITH THE FRYER IN AN AREA VISIBLE TO THE FRYER OPERATOR.

CLEAN KETTLE BEFORE USING

Take out baskets, push and hold element catch, lift up on element lift handle until elements lock in a vertical position, and remove kettle. The kettle can be cleaned in a sink like any other pot or container.

ADDING FAT

Replace kettle and swing the element down, making fryer ready for use. Add fat. Each kettle has a 15 lb. fat capacity. A fat level line on the rear of the kettle will guide you in determining the minimum cold fat level. A higher fat level can be used when frying bulky foods, such as chicken or fish cakes. The fat level should be chosen carefully so that the foaming action of the fat does not spill out of the kettle. If solid shortening is used, pack carefully around the elements.



CONTROLS

1. **ON/OFF TWO-POLE SWITCH** - Located on the front panel is a two-pole switch which turns power on or off. An indicator light (Power On) is located on the control housing.
2. **THERMOSTAT CONTROL** - Located on the Control Housing, this control allows you to select the desired frying temperature. A signal light "Heating" indicates when the element is on. When the light goes off, the desired temperature has been reached.
3. **HI-LIMIT THERMOSTAT** - Should fat temperatures reach 450° F (230° C), this control will shut off the power to the heating elements. The unit will still have power. The fat temperature must cool to 400° F (202.4° C) and the manual reset button located on the back panel of the control housing must be pressed to restore operation. Should the hi-limit control activate twice in succession, the primary thermostat should be checked for malfunction by a qualified service technician. Each pot is equipped with its own HI-LIMIT THERMOSTAT.

FRYING

After fat has been added, turn the switch on and set the thermostat at 200° F (92.4° C). After the fat has melted, turn the thermostat to the desired setting. Included in this instruction booklet is a frying chart and some helpful hints on fat use. After the selected fat temperature has been reached, slowly lower half filled baskets into the fat. Do not overload baskets as this causes foods to be improperly fried.

NOTE: Baskets should be allowed to drain after frying cycle. The kettle handles serve as basket hangers.

IDLING

During idle periods turn thermostat control to approximately 200° F (92.4° C). The fast recovery fryers can be brought up to frying temperature in a matter of minutes. Lowering the temperature during idle periods saves energy costs and prolongs fat life.

DRAINING KETTLE

Turn switch to "OFF". Raise element to the first stop and allow to drain. Raise the element to the vertical position and siphon the oil out of the kettle.



DO NOT ATTEMPT TO REMOVE THE KETTLE FILLED WITH HOT OIL. CONTACTING HOT OIL CAN RESULT IN SEVERE INJURIES OR DEATH.

If you do not have a siphon, order one from your dealer or dip the oil out and strain into a container. After oil has been removed, remove the kettle and clean.



INAPPROPRIATE USE DUE TO A LACK OF COMMON SENSE MAY RESULT IN PRODUCT DAMAGE OR PERSONAL INJURY.

CLEANING THE EXTERIOR

The exterior surfaces can be cleaned by regularly wiping with a soft cloth. Any discoloration can be removed with a non-abrasive cleaner.

CAUTIONS FOR ALL DEEP FAT FRYERS

NEVER LEAVE AN OPERATING FRYER UNATTENDED

REMEMBER HOT OIL IS DANGEROUS – RESPECT IT!



WARNING – INSTALLATION

- Locate your fryer in a protected place so that it cannot be tipped over or knocked off its support. A mechanical restraint should be installed to prohibit the fryer from tipping or moving. Consult your local codes for allowable methods of restraint.
- Install an automatic fire extinguisher over the fryer and in the exhaust duct.
- Be sure your power supply is installed properly and in accordance with the local and national codes.
- Install a shut-off switch or gas valve close to the fryer. It must turn off the fryer immediately.
- Failure to add a mechanical restraint can result in oil splashing out and contacting the skin, leading to serious injury or death!



WARNING – HOT OIL

- Hot oil is dangerous – Severe burns can result when hot oil contacts the skin.
- Hot oil is flammable – Keep open flames away from hot oil and its vapors.
- Never allow water or ice to get in hot oil.

IT CAN EXPLODE!



WARNING - ENVIRONMENT

- Keep your floors clean and free of grease and all other substances so no one slips accidentally and contacts the hot fryer.
- Keep areas and filters clean above your fryers – Oil soiled lint or dust can ignite easily and flames will spread rapidly.



WARNING – MAINTENANCE

- Have your equipment checked regularly to insure its safe and properly functioning.
- If your fryer starts to smoke or boil abnormally, cut off the power supply immediately and determine the reason for the smoking or boiling before attempting to use it again.



WARNING – TRAINING

- Train all personnel to understand the hazards of hot oil. Instruct them on the proper action to take if something does not seem to be acting properly.
- Instruct your personnel on what to do if there is an oil fire. Do not use water on an oil fire! Use only fire extinguishers of the approved type and never direct such extinguishers so as to blow the oil out of the oil container.
- Inappropriate use due to a lack of common sense may result in product damage or personal injury.

CARE OF FAT

In three to six months you may spend as much for fat as you paid for your kettle. So fat is an item you want to know all about; how to select it; how to manage it. The more production you can get from each pound of fat, the more profitable your frying operation will be.

To get a high rate of production per pound of fat you have to avoid two things. One is early breakdown and spoilage of the compound so that you have to throw it away before it does enough work to "earn its keep." The other is excessive sponging up of fat by the food being fried.

The main cause of fat breakdown is excessive heat. On the other hand abnormal absorption is caused by frying too long at too low temperatures. One answer to both problems is exact control of heat — so that fat neither smokes up nor soaks up.

Of course, no fat "keeps" forever. Not only heat, but air and moisture, salt particles and crumbs of food work to break it down. But you can slow up fat deterioration by maintaining proper temperatures and by draining your kettle, filtering or straining the fat once or twice a day and by keeping the kettle itself absolutely clean.

A number of commercial devices and materials are available to aid in eliminating fat impurities. There are several excellent models of pressure filters as well as strainer-type filters, which, if used regularly, will prolong life of fat.

However, no purification device will renew broken down or rancid fat or put new life into it. Once you have allowed fat to break down it becomes unsuitable for frying — in fact browning is impossible.

In addition to filtration, you can prolong the usefulness of fat by sweetening it with fresh compound every day - replacing about 15% of the bulk you started with. If you do enough frying so that normal absorption of fat in food amounts to 15% to 20% of the capacity of your kettle every day - then you can call that your turn-over food. It means you can add the recommended 15% of fresh fat without discarding any of the old.

10 POINT PROGRAM

TO PRESERVE FAT AND PRODUCE THE FINEST FRIED FOODS

1. Choose a fat that does not break down quickly. Hydrogenated shortening, corn, and peanut oils are less likely to break down under high temperatures.
2. Do not fry foods at temperatures above those recommended. The higher the fat temperature, the more rapid the rate of fat deterioration. Above 400°F fats quickly deteriorate.
3. During short intervals between frying, turn the heat down. Do not keep heat on for long periods between batches.
4. Keep fat clean. Strain or filter daily or at end of each shift. Add at least 15% fresh fat to your kettle daily.
5. At least once a day, cool a small amount of fat and taste it to see if it has picked up foreign flavors.
6. Discard fat that tends to bubble excessively before food is added.
7. Do not overload baskets-pieces should not touch when frying. Shake baskets to prevent food from sticking together. Fry similar sizes together.
8. Never salt foods directly over fat, salt in fat reduces its life.
9. Raw, wet foods, such as potatoes and oysters, should be drained or wiped dry before frying to extend the life of the frying fat. Have foods to be fried at room temperature.
10. Keep fat temperatures below smoking point to minimize frying odors.

HANDY FRYING CHART

FOOD	COATING	PROCEDURE	TEMP	TIME IN MINUTES
POTATOES				
Standard French Fries		Cut in uniform pieces 1/2" square the long way	350°	5-7
Blanch Only			350°	3-1/2
Brown Only			350°	3-1/2
Long Branch		Cut in uniform pieces 3/4" square the long way	350°	7-10
Julienne (shoe string)		Cut in uniform pieces 1/8" to 1/4" square the long way	350°	3-6
Chips		Soak in cold running water until water does not run milky	350°	2-3
CHICKEN				
Large Pieces	Batter or	Some prefer rolling in	325°	9-11
Small Pieces	Breading	seasoned flour, dipping in egg	340°	7-10
Pre-cooked		wash, and frying	350°	3-4
FISH				
Fillets (Large)	Breading	Select fillets of uniform	350°	4
Fillets (Small)	or Batter	size, skin out and dry.	350°	3
Oysters	Breading	Use Oyster liquor in batter		
	or Batter	or breading	350°	5
Clams	Batter		350°	1
Scallops	Breading		350°	4
Shrimp	Batter	Some prefer soaking 1/2 hour		
		in cold seasoned milk	350°	3
Smelts	Breading	Cut spinal cord several	350°	4
		places to prevent curling		
MEATS				
Chicken Fried Steak	Breading	Sever all connecting membranes		
		at one inch intervals to prevent		
		curling	360°	3-4
Cutlets	Breading		350°	3-4
Chops	Breading		340°	3-4
Meat Balls	Breading or			
	rolled in flour		340°	4-6
Brains	Breading		340°	3-5
VEGETABLES				
Asparagus	Batter or crumbs	Pre-cook in salted water	350°	3
Cauliflower	Batter or crumbs	Pre-cook and separate flowers	350°	3
Egg Plant	Crumb Breading	Peel, cut cross-wise into 1/4" slices	350°	3
Onions	Light batter	Slice thin, soak in milk for two hours	350°	3
FRITTERS				
Fruit (bananas, pineapples, apricots, berries)		Serve with fruit juice	350°	3-5
Corn	Batter	Serve with syrup or jelly	350°	3-5
Vegetable (peas, green beans)		Serve with tomato cheese sauce	350°	5-8
MISCELLANEOUS				
Croquettes	Breading		360°	3
Chinese Noodles			375°	1-2
French Toast			375°	1
DOUGHNUTS				
Cake			375°	1-1/2 - 2
Yeast, raised			375°	1

THOROUGHLY INSPECT YOUR UNIT ON ARRIVAL

This unit has been tested for proper operation before leaving our plant to insure delivery of your unit in perfect condition. However, there are instances in which the unit may be damaged in transit. In the event you discover any type of damage to your product upon receipt, you must immediately contact the transportation company who delivered the item to you and initiate your claim with same. If this procedure is not followed, it may affect the warranty status of the unit.

LIMITED EQUIPMENT WARRANTY

All workmanship and material in Star products have a one (1) year limited warranty on parts & labor in the United States and Canada. Such warranty is limited to the original purchaser only and shall be effective from the date the equipment is placed in service. Star's obligation under this warranty is limited to the repair of defects without charge, by the factory authorized service agency or one of its sub-agencies. Models that are considered portable (*see below*) should be taken to the closest Star service agency, transportation prepaid.

- > Star will not assume any responsibility for loss of revenue.
- > On all shipments outside the United States and Canada, see International Warranty.
- * The warranty period for the JetStar six (6) ounce & Super JetStar eight (8) ounce series popcorn machines is two (2) years.
- * The warranty period for the Chrome-Max Griddles is five (5) years on the griddle surface. See detailed warranty provided with unit.
- * The warranty period for Teflon/Dura-Tec coatings is one year under normal use and reasonable care. This warranty does not apply if damage occurs to Teflon/Dura-Tec coatings from improper cleaning, maintenance, use of metallic utensils, or abrasive cleaners, abrasive pads, product identifiers and point-of-sale attachments, or any other non-food object that comes in continuous contact with the roller coating. This warranty does not apply to the "non-stick" properties of such materials.
- > This warranty does not apply to "Special Products" but to regular catalog items only. Star's warranty on "Special Products" is six (6) months on parts and ninety (90) days on labor.
- > This warranty does not apply to any item that is disassembled or tampered with for any purpose other than repair by a Star Authorized Service Center or the Service Center's sub-agency.
- > This warranty does not apply if damage occurs from improper installation, misuse, wrong voltage, wrong gas or operated contrary to the Installation and Operating instructions.
- > This warranty is not valid on Conveyor Ovens *unless* a "start-up/check-out" has been performed by a Factory Authorized Technician.

PARTS WARRANTY

Parts that are sold to repair out of warranty equipment are warranted for ninety (90) days. The part only is warranted. Labor to replace the part is chargeable to the customer.

SERVICES NOT COVERED BY WARRANTY

1. Travel time and mileage rendered beyond the 50 mile radius limit
2. Mileage and travel time on portable equipment (*see below*)
3. Labor to replace such items that can be replaced easily during a daily cleaning routine, ie; removable kettles on fryers, knobs, grease drawers on griddles, etc.
4. Installation of equipment
5. Damages due to improper installation
6. Damages from abuse or misuse
7. Operated contrary to the Operating and Installation Instructions
8. Cleaning of equipment
9. Seasoning of griddle plates
10. Voltage conversions
11. Gas conversions
12. Pilot light adjustment
13. Miscellaneous adjustments
14. Thermostat calibration and by-pass adjustment
15. Resetting of circuit breakers or safety controls or reset buttons
16. Replacement of bulbs
17. Replacement of fuses
18. Repair of damage created during transit, delivery, & installation OR created by acts of God

PORTABLE EQUIPMENT

Star will not honor service bills that include travel time and mileage charges for servicing any products considered "Portable" including items listed below. These products should be taken to the Service Agency for repair:

- * The Model 510FD Fryer.
- * The Model 526TOA Toaster Oven.
- * The Model J4R, 4 oz. Popcorn Machine.
- * The Model 518CMA & 526CMA Cheese Melter.
- * The Model 12MC & 15MC & 18MCP Hot Food Merchandisers.
- * The Model 12NCPW & 15NCPW Nacho Chip/Popcorn Warmer.
- * All Hot Dog Equipment **except Roller Grills & Drawer Bun Warmers.**
- * All Nacho Cheese Warmers **except Model 11WLA Series Nacho Cheese Warmer.**
- * All Condiment Dispensers **except the Model HPD & SPD Series Dispenser.**
- * All Specialty Food Warmers **except Model 130R, 11RW Series, and 11WSA Series.**
- * All QCS/RCS Series Toasters **except Model QCS3 & RCS3 Series.**
- * All Fast Steamer Models **except Direct Connect Series.**

ALL:

- * Pop-Up Toasters
- * Butter Dispensers
- * Pretzel Merchandisers
(Model 16PD-A Only)
- * Pastry Display Cabinets
- * Nacho Chip Merchandisers
- * Accessories of any kind
- * Sneeze Guards
- * Pizza Ovens
(Model PO12 Only)
- * Heat Lamps
- * Pumps-Manual

The foregoing warranty is in lieu of any and all other warranties expressed or implied and constitutes the entire warranty.

FOR ASSISTANCE

Should you need any assistance regarding the Operation or Maintenance of any Star equipment; write, phone, fax or email our Service Department. In all correspondence mention the Model number and the Serial number of your unit, and the voltage or type of gas you are using.

RIGHT HAND CONTROL
HOUSING ASSEMBLY
530015

LEFT HAND CONTROL
HOUSING ASSEMBLY
530016

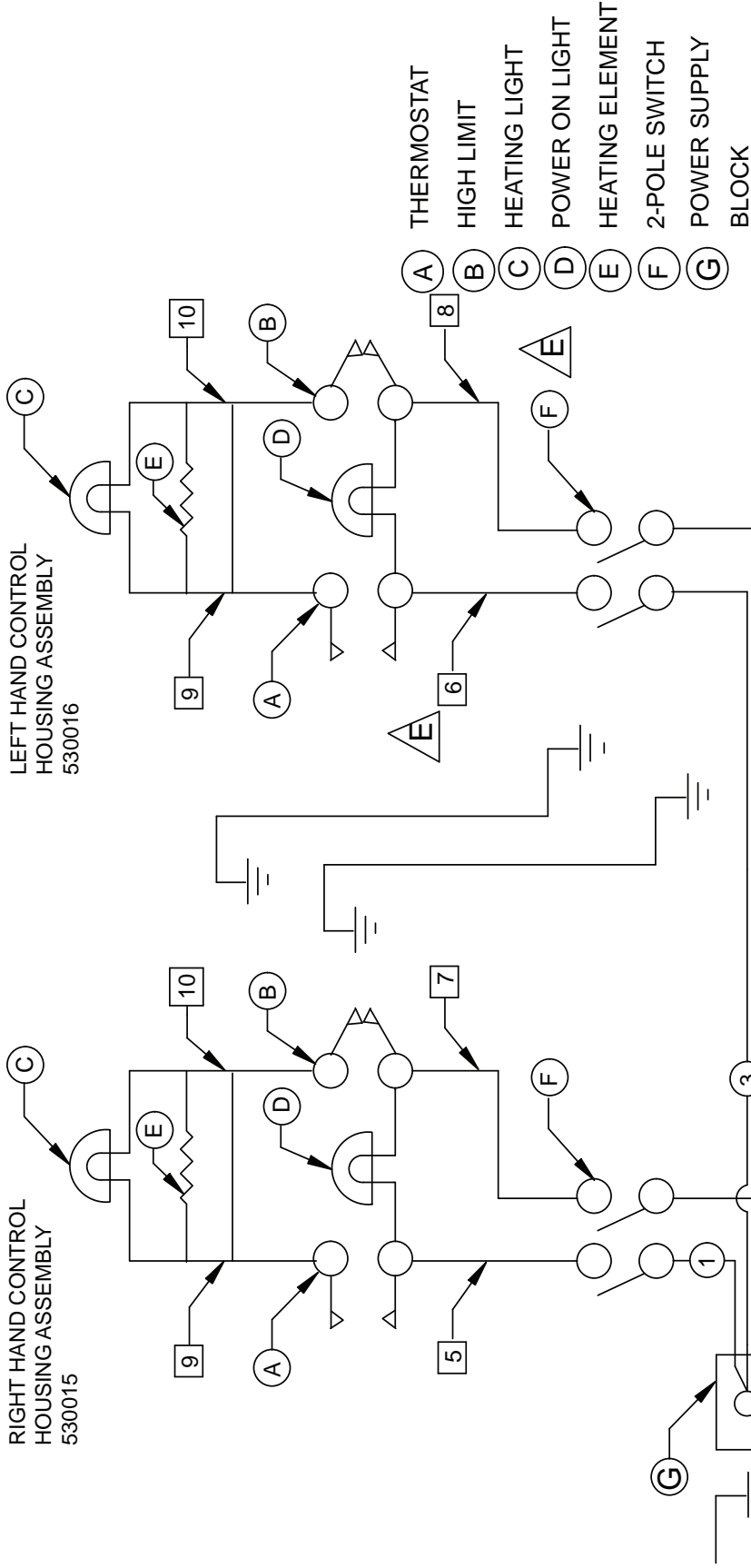

FOR SUPPLY CONNECTION USE COPPER WIRE RATED AT LEAST 90°C.

	MODEL 530TE, TED	MODEL 530T, TD
	240V 1 PH.	208V 1 PH.
WATTS	9200	8638
AMPS	38.3	41.5
SUPPLY MIN AWG	#8	#8
	240V 1 PH.	240V 1 PH.
	11500	11500
	47.9	47.9
	#6	#6

MODEL: GR/CG10I-230/240V, GR/CG14I-230/240V

THIS DRAWING CONTAINS INFORMATION CONFIDENTIAL TO STAR MFG. INTL. INC.
NO REPRODUCTION OR DISCLOSURE OF ITS CONTENTS IS PERMITTED.



STAR MANUFACTURING INTERNATIONAL INC.

SK1239

Rev F

5/1/2003

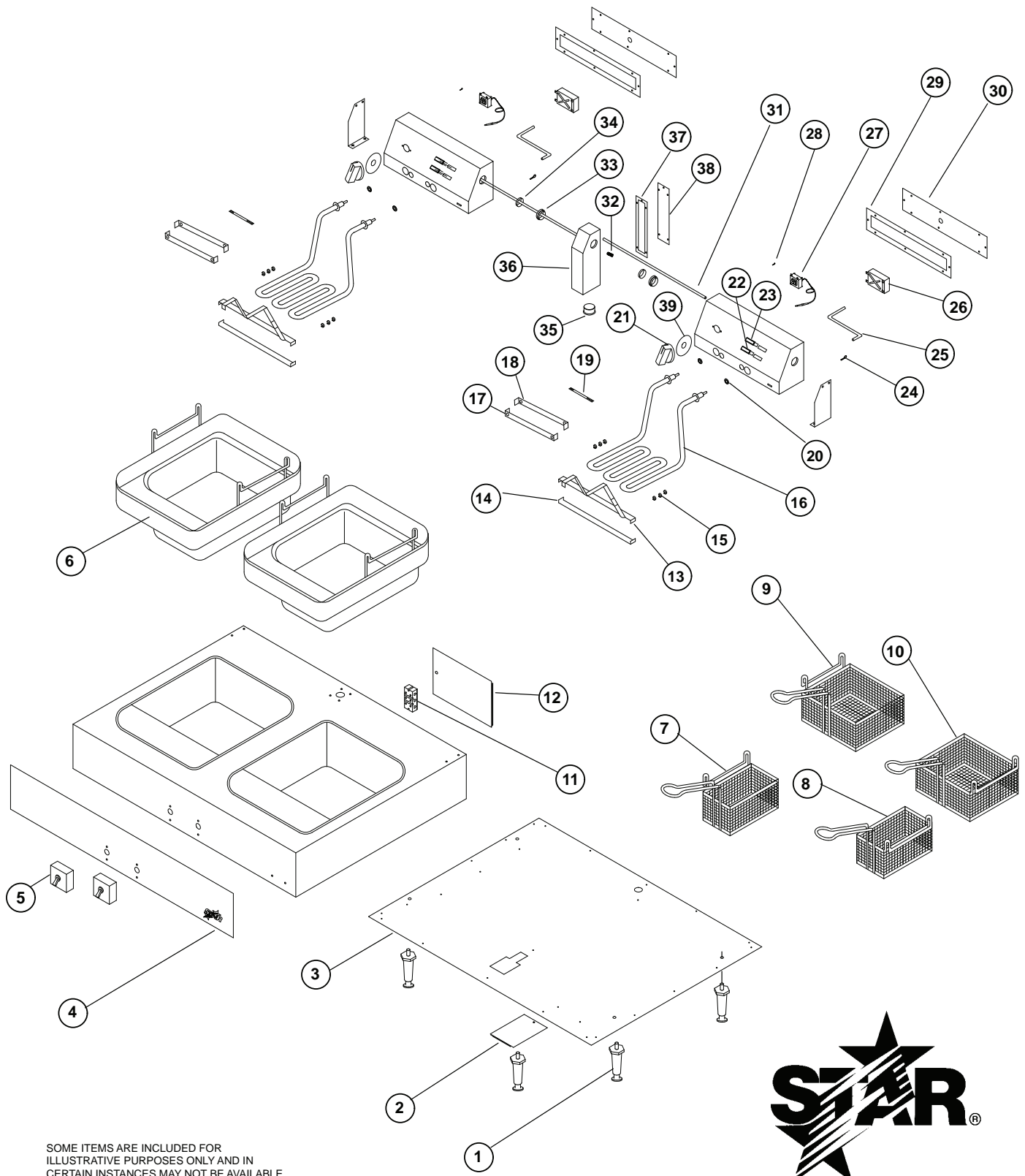

SOME ITEMS ARE INCLUDED FOR
ILLUSTRATIVE PURPOSES ONLY AND IN
CERTAIN INSTANCES MAY NOT BE AVAILABLE

MODEL - 530TD & 530TED



STAR MANUFACTURING INTERNATIONAL, INC.

SK1602

REV. C

7/08/05

PARTS LIST

January 26, 2009, Rev C

MODEL 530TD/TED Deep Fat Fryer

Key Number	Part Number	Number Per Unit	Description and Model Designation
1	2A-Z5942	4	LEG
2	E1-Y5083	1	PANEL, INSPECTION, SMALL
3	E1-530071	1	BOTTOM ASSEMBLY
4	2M-Z6228	1	FACEPLATE (For Superior Model use 2M-Z6223)
5	2E-Y5166	2	SWITCH - 2 POLE 30 AMP
6	E1-115714	2	KETTLE ASSEMBLY, COMPLETE
7	2B-115774	2	BASKET - TWIN, LEFT HANGER (OPTIONAL)
8	2B-115775	2	BASKET - TWIN, RIGHT HANGER (OPTIONAL)
9	2B-Y8847	1	BASKET - HANGER LT
10	2B-Y8846	1	BASKET - HANGER RT
11	2E-Y2849	1	TERMINAL BLOCK
12	E1-Y5084	1	PANEL, INSPECTION
13	E1-115719	2	ELEMENT HANDLE ASSEMBLY
14	E1-Y1669	2	UPPER ELEMENT CLAMP
15	2P-5737	12	CLIP - CAPILLARY TUBE
16	2N-Y5168	2	ELEMENT 240V, 5750W
	2N-Y5169	2	ELEMENT 240V, 4600W
17	E1-Y1889	2	BRACE - ELEMENT (LONG)
18	E1-Y1890	2	BRACE - ELEMENT (SHORT)
19	E1-7363	2	CLAMP - THERMOSTAT BULB
20	2I-5659	4	GROMMET - CAPILLARY TUBE
21	2R-Z1298	2	KNOB - THERMOSTAT
22	E1-116314	2	SIGNAL LIGHT - POWER ON (WHITE)
23	E1-116313	2	SIGNAL LIGHT - HEATING (AMBER)
24	2A-5401	2	PIN - COTTER (3/4")
25	E1-Y5108	2	ROD - CATCH RELEASE
26	2T-Z7208	2	THERMOSTAT
27	2T-Y1668	2	SAFETY THERMOSTAT
28	2A-7435	2	PIN - COTTER (3/8")
29	2I-Y5097	2	GASKET - ELEMENT HOUSING
30	E1-Y5286	2	BACK - ELEMENT HOUSING
31	E1-Y5109	2	ROD - CATCH
32	2P-7969	2	SPRING
33	E1-Y5090	2	PIVOT BUSHING
34	2I-Y5088	2	GASKET - PIVOT
35	2K-Y5093	1	BUSHING - 1"
36	E1-530005	1	WIRE HOUSING ASSEMBLY
37	2I-Y5095	1	GASKET - WIRE HOUSING
38	E1-Y5086	1	BACK - WIRE HOUSING
39	2M-Z7219	2	SIGN - LABEL, TEMP SETTINGS
NI	2M-Z8942	1	LABEL-FRYER BURN WARNING
NI	2M-Z8943	1	SIGN-FRYER WARNINGS
NI	2M-Y2089	1	LABEL-RESET
NI	2M-Y5135	1	LABEL WIRING DIAGRAM
NI	2P-Y3406	2	WIRE SPACER, THERMOSTAT BULB - .302 DIA.
NI	2P-Y3453	2	WIRE SPACER, SAFTEY THERMO BULB - .350 DIA.

530TD
530TED

**IMPORTANT: WHEN ORDERING, SPECIFY VOLTAGE OR TYPE GAS DESIRED
INCLUDE MODEL AND SERIAL NUMBER**

PAGE 1
OF 1

Some items are included for illustrative purposes only and in certain instances may not be available.



Star Manufacturing International, Inc.

STAR INTERNATIONAL HOLDINGS INC. COMPANY

Star - Holman - Lang - Wells - Bloomfield - Toastmaster

10 Sunnen Drive, St. Louis, MO 63143 U.S.A.

(314) 781-2777

www.star-mfg.com