

030897
Cleaning Brush 13"



030896
Cleaning Brush 8.5"



019972
Cleaning Brush (older units)



FP2000 *no longer in production*

FP2100 *no longer in production*

FP2200 /Batch Bowl & Continuous Feed

FP2200U /Unipro with CAF22 & CAF26

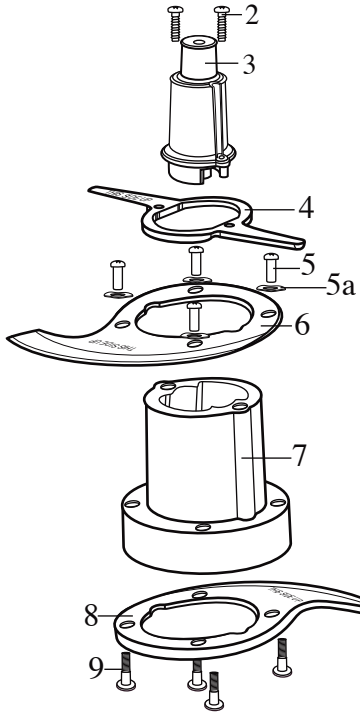

503341
S Blade Cutter Assembly

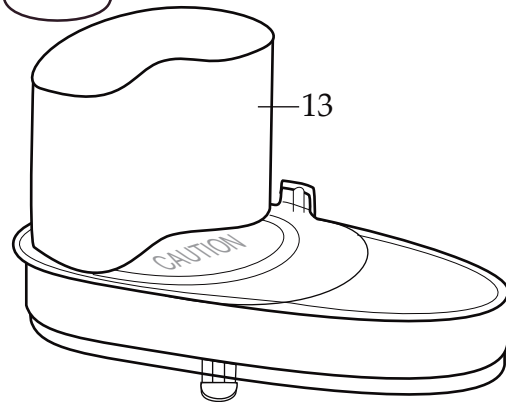
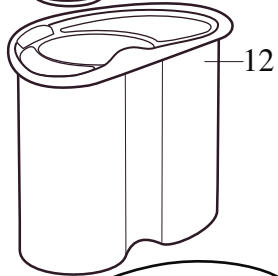
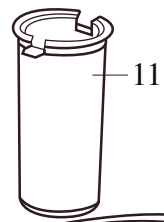

013304
NSF Seal

Unit Information
50/60 HZ – 5.6 Amps. – 3/4 HP
Round work bowl can hold
4 qts. wet and 6 qts. dry
Continuous feed can process
1,400 lbs. per hour
Warranty 5 yr. limited motor
plus 2 yr. parts and labor

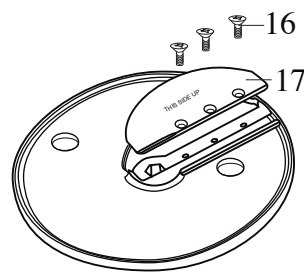

024165
1/8" Slicer (CAF12)

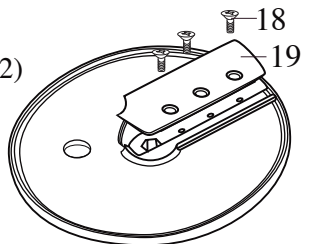

024171
1/2" Slicer (CAF18)

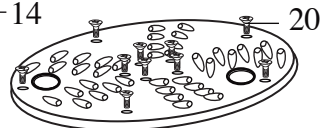
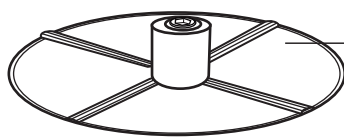
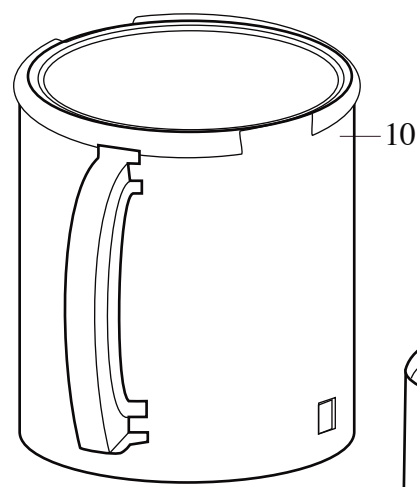

024173
3/16" Shredder (CAF20)

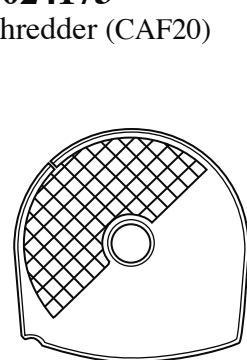
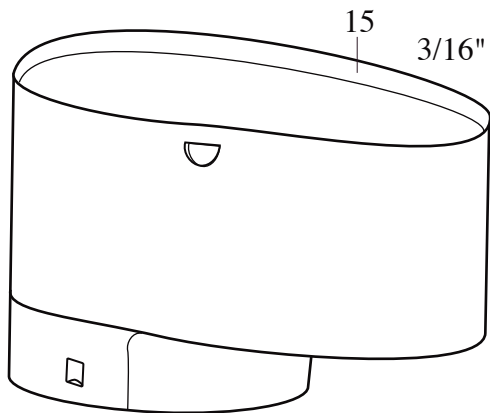

024177
3/4" Dicer (CAF25)

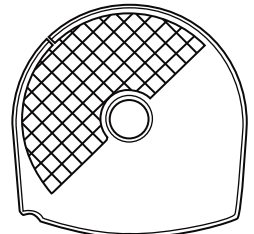

024176
1/2" Dicer (CAF24)

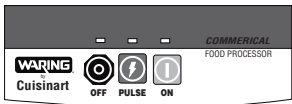

032621
Nameplate (current)

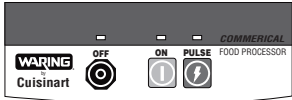

019573
Nameplate (older units)



FP2000 *no longer in production*
FP2100 *no longer in production*
FP2200 /Batch Bowl & Continuous Feed
FP2200U /Unipro with CAF22 & CAF26

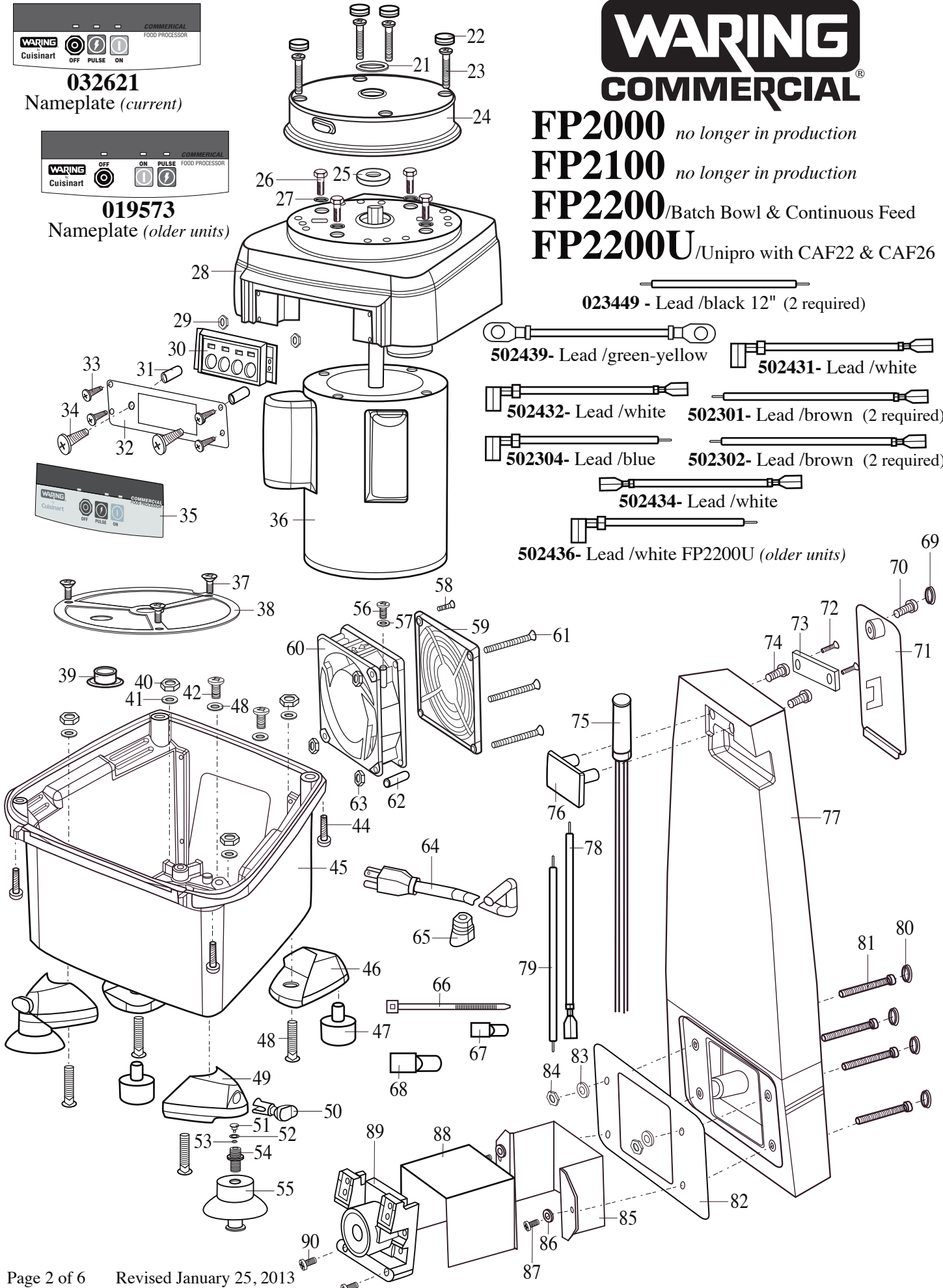



023449 - Lead /black 12" (2 required)

- 502439**- Lead /green-yellow
- 502431**- Lead /white
- 502432**- Lead /white
- 502301**- Lead /brown (2 required)
- 502304**- Lead /blue
- 502302**- Lead /brown (2 required)
- 502434**- Lead /white
- 502436**- Lead /white FP2200U (older units)

Catalog	Model
FP2000 <i>no longer in production</i>	32FP18
FP2100 <i>no longer in production</i>	32FP19
FP2200/FP2200U	32FP20

Waring Factory Service Center
 314 Ella T. Grasso Ave.
 Torrington, CT 06790
 Tele. 1-800-269-6640
 Fax 860-496-9017
 www.waringcommercialproducts.com

Illustration #	Part #	Description
1	502503	Batch Bowl Cover Assembly
2	024005	Screw (2 required)
3	029372 023988	Top Center Hub Top Center Hub (<i>2nd generation & older units - N/A Use 503341</i>)
4	019670	Mid Blade
5	029370 019984	Special Nut (4 required) Special Nut (4 required <i>2nd generation & older units - N/A Use 503341</i>)
5a	029371	Wave Washer (4 required <i>current production</i>)
6	030333	Cutter Blade
7	029373 023989	Center Hub Center Hub (<i>2nd generation & older units - N/A Use 503341</i>)
8	030333 019580	Cutter Blade Lower "S" Blade Cutter (<i>2nd generation & older units - N/A Use 503341</i>)
9	029369 023029	Special Screw (4 required) Special Screw (4 required <i>2nd generation & older units - N/A Use 503341</i>)
10	019578	Batch Bowl
11	025285 024032 019834	Plunger Insert (dark gray) Plunger Insert (light gray <i>older units</i>) Plunger Insert (clear <i>older units before Sept. 99</i>)
12	025284 019579	Plunger (dark gray - kidney shape  Plunger (white - half circle shape <i>older units before Sept. 99</i> 
13	502583 502504 502293	Continuous-Feed Cover Assembly use kidney plunger Continuous-Feed Cover Assembly use kidney plunger (<i>older units</i>) Continuous-Feed Cover Assembly use half circle plunger (<i>units before Sept. 99</i>)
14	025286-E	Slinger Disk (gray)
15	025281 019581	Continuous-Feed Bowl (dark gray) Continuous-Feed Bowl (light gray <i>older units</i>)
16	019983	Flat Head Screw (3 required)
17	019689	Slicing Blade
18	023464	Flat Head Screw (3 required)
19	023055	Slicing Blade
20	019981	Screw (10 required)
21	018008	Washer
22	025294 019812	Plug (dark gray 4 required) Plug (light gray <i>older units</i> 4 required)
23	019974	Screw (4 required)
24	019566	Locking Ring
25	018004	Seal
26	020325	Hex Bolt (4 required)
27	021082	Washer (4 required)

CatalogFP2000 *no longer in production*FP2100 *no longer in production*

FP2200/FP2200U

Model

32FP18

32FP19

32FP20



Illustration #	Part #	Description
28	502963	Top Housing (dark gray)
	502385	Top Housing (light gray <i>older units - N/A Use 502963</i>)
29	001856	Kep Nut (2 required)
30	016439	Tap Touch Switch
	019954	Tap Touch Switch (<i>older units must use with 019573 nameplate</i>)
31	019641	Switch Spacer (2 required)
32	019572	Switch Plate
33	019096	Screw (4 required)
34	019973	Screw (2 required)
35	032621	Name Plate
	019573	Name Plate (<i>older units must use with 019954 tap touch switch</i>)
36	019574	Motor 3/4 HP
37	016317	Screw (3 required)
38	023233	Screen (punched)
39	023211	Snap Bushing
40	023073	Nut (4 required)
41	018314	Washer (4 required)
42	017408	Screw (2 required)
43	002943	Washer (2 required)
44	019098	Screw (4 required)
45	025282	Bottom Housing (dark gray)
	019787	Bottom Housing (light gray <i>older units - N/A Use 025282</i>)
46	025292	Rear Foot Support (dark gray-2 required)
	019968	Rear Foot Support (light gray <i>older units 2 required</i>)
47	018790	Foot (2 required)
48	023072	Carriage Bolt (4 required)
49	024293	Front Foot Support (dark gray-2 required)
	024052	Front Foot Support (light gray <i>older units 2 required</i>)
50	024037	Front Foot Actuator (2 required)
51	024039	Valve Foot Pin (2 required)
52	024040	Curved Spring Washer (2 required)
53	024042	Foot "O" Ring (2 required)
54	024038	Actuator Shaft (2 required)
55	024053	Suction Cup Foot (2 required)
56	023437	Screw
57	002943	Washer
58	023436	Screw

CatalogFP2000 *no longer in production*FP2100 *no longer in production*

FP2200/FP2200U

Model

32FP18

32FP19

32FP20



Illustration #	Part #	Description
59	023412	Fan Guard
	023454	Fan Guard (<i>older units</i>)
60	023411	Fan
61	023416	Screw (3 required)
62	002613	Insulating Sleeve
63	001856	Kep Nut (3 required)
64	014236	Cord Set
65	018811	Strain Relief
66	013731	Cable Tie (3 required)
67	012409	Small Crimp Connector (3 required)
68	019123	Large Crimp Connector (2 required)
69	025294	Plug (dark gray)
	019812	Plug (light gray <i>older units</i>)
70	019978	Screw
71	025288	Back Plate (dark gray)
	019055	Back Plate (light gray <i>older units</i>)
72	019980	Screw (2 required)
73	019979	Clamp Sensor
74	019977	Screw (2 required)
75	021741	Sensor
76	025289	Insert (dark gray)
	019562	Insert (light gray <i>older units</i>)
77	502578	Tower Assembly (dark gray)
78	502306	Lead
79	023936	15 ¹ / ₂ " Lead (black)
80	025294	Plug (dark gray-4 required)
	019812	Plug (light gray <i>older units</i> 4 required)
81	023325	Screw (4 required)
82	023328	Tower Gasket
83	002943	Washer (2 required)
84	016716	Hex Nut (2 required)
85	023326	Relay Bracket
86	002943	Washer (2 required)
87	016690	Screw (2 required)
88	023360	Splash Guard
89	019569	Relay
90	023347	Screw (2 required)

Catalog

FP2000 *no longer in production*
 FP2100 *no longer in production*
 FP2200/FP2200U

Model

32FP18
 32FP19
 32FP20

Waring Factory Service Center
 314 Ella T. Grasso Ave.
 Torrington, CT 06790
 Tele. 1-800-269-6640
 Fax 860-496-9017
 www.waringcommercialproducts.com

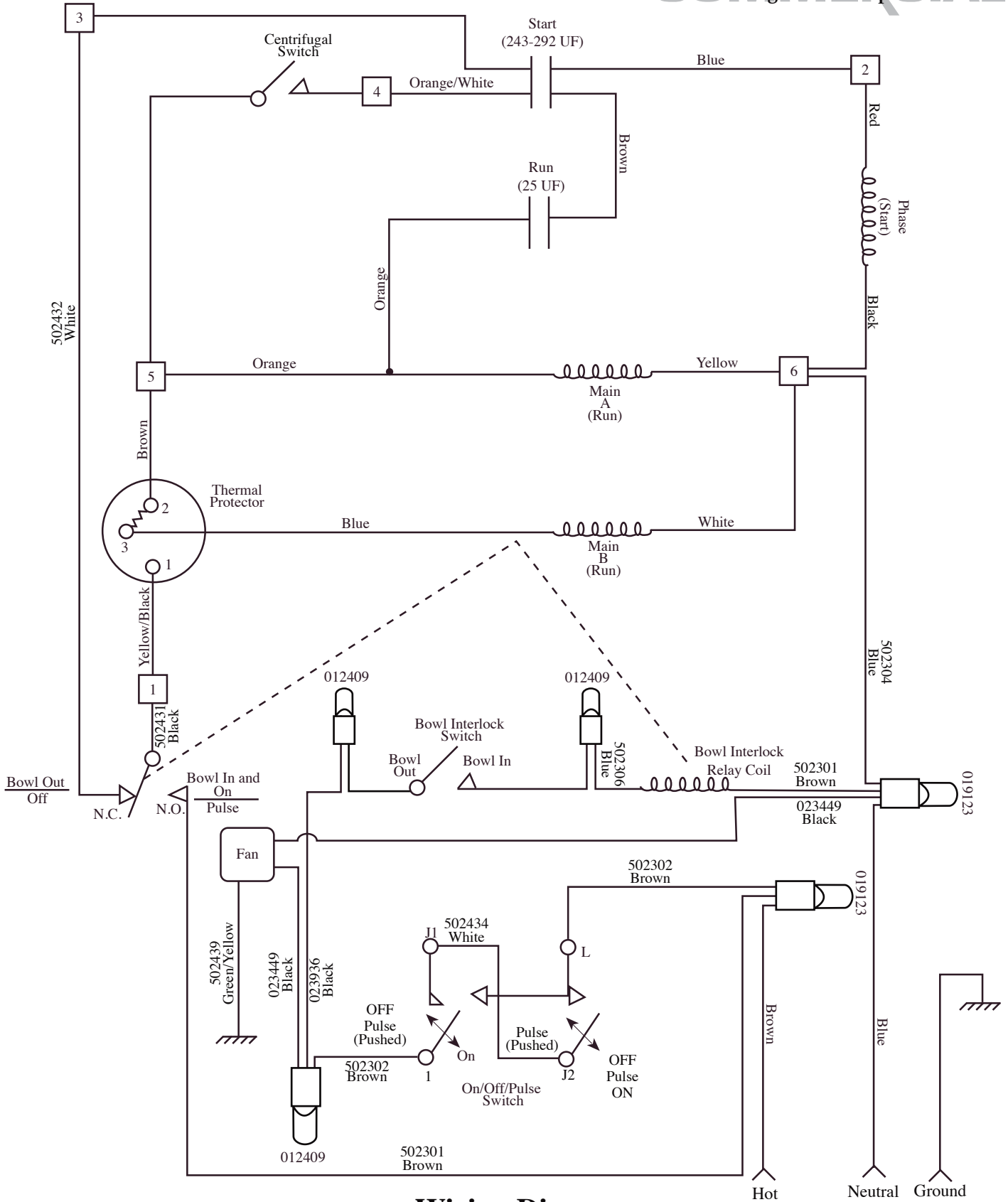

Wiring Diagram